

The book cover features a vertical split design. The left side is a teal color with faint musical notes and a large, semi-transparent treble clef. The right side is divided into three horizontal bands: a dark blue top band with faint musical notes, a green middle band with the title and subtitle, and a red bottom band with faint musical notes. The title 'Still Singing' is written in a white, elegant cursive font across the green band. Below it, the subtitle 'HYMN STORIES FOR EVERY SEASON' is written in a white, all-caps serif font. The author's name 'KIM SORGIUS' is at the bottom right in a white, all-caps serif font.

# *Still Singing*

HYMN STORIES  
FOR EVERY SEASON

KIM SORGIUS

*Dedicated to my daughter, Leah, the author of  
many of the hymn stories featured in  
this book. Her love for music and her love  
for the Lord is a beautiful inspiration.*



Copyright Kim Sorgius 2020.

ALL RIGHTS RESERVED. This book contains material protected under International and Federal Copyright Laws and Treaties. Any unauthorized reprint or use of this material is prohibited. No part of this book may be reproduced or transmitted in any form or by any means, electronic or mechanical, including photocopying, recording, or by any information storage and retrieval system without express written permission from the author / publisher.

Unless otherwise indicated, all Scripture quotations are from The Holy Bible, English Standard Version® (ESV®), copyright © 2001 by Crossway, a publishing ministry of Good News Publishers. Used by permission. All rights reserved.

All Scripture quotations marked (KJV) are from The Holy Bible, King James Version. Public Domain.

The purchaser of this ebook has permission to print unlimited copies of the ebook text and journal for immediate family use only. For any group consisting of more than one immediate family, each family is required to purchase a copy of this ebook.

If you desire to use this study for a church class or group, please contact Not Consumed Ministries for more information, [kim@notconsumed.com](mailto:kim@notconsumed.com).



# Thank You!

WE ARE SO EXCITED ABOUT THE  
HYMNOLOGICAL JOURNEY YOU  
ARE ABOUT TO TAKE!

AS YOU GO THROUGH THE  
MUSIC THEORY LESSONS, HOP  
ON OVER TO OUR VIDEOS TO  
HELP YOU AS YOU LEARN:

[www.notconsumed.com/music-theory/](http://www.notconsumed.com/music-theory/)



# Table of Contents

He Keeps Me Singing . . . . .	4	'Tis So Sweet to Trust in Jesus. . . . .	132
Amazing Grace. . . . .	12	Turn Your Eyes Upon Jesus . . . . .	140
Blessed Assurance . . . . .	20	I Stand Amazed in the Presence . . . . .	148
Take My Life and Let It Be. . . . .	28	Be Thou My Vision. . . . .	156
What a Friend We Have in Jesus. . . . .	36	Stand Up, Stand Up for Jesus. . . . .	164
A Mighty Fortress Is Our God . . . . .	44	Come, Thou Fount of Every Blessing. . . . .	172
It Is Well with My Soul. . . . .	52	Jesus Paid It All . . . . .	180
I Have Decided to Follow Jesus . . . . .	60	At Calvary . . . . .	188
Count Your Blessings. . . . .	68	Christ the Lord Is Risen Today . . . . .	196
Praise God, From Whom All Blessings Flow. . . . .	76	He Lives . . . . .	204
Great Is Thy Faithfulness . . . . .	84	In the Garden . . . . .	212
O Come, O Come, Emmanuel . . . . .	92	Trust and Obey. . . . .	220
Silent Night . . . . .	100	When We All Get to Heaven . . . . .	228
God Rest Ye Merry, Gentlemen . . . . .	108	The Star-Spangled Banner. . . . .	236
Joy to the World. . . . .	116	My Country, 'Tis of Thee . . . . .	244
O For a Thousand Tongues to Sing. . . . .	124	America the Beautiful . . . . .	252



# HE KEEPS ME SINGING

*the story*

Have you ever noticed how powerful music can be? A song can help us memorize Scripture, remember God's truth in a situation, or encourage us to keep trusting God even when life gets tough. This whole book is filled with hymns people have been using for hundreds of years to help them do those things, and I can't wait to share them with you!

Although it's not the oldest hymn, "He Keeps Me Singing" is the first one we are going to study because it tells the story of how God keeps us singing no matter what happens in life. As the title of the book says, we want to live a life "Still Singing" His praises.



"He Keeps Me Singing" was written by Luther Bridgers in 1910. A pastor in Kentucky, you might say Luther had it all. He was good at his job and well respected as an evangelist and church planter. He had a wonderful wife and three precious boys.

One night while visiting family, the house caught on fire. His wife and all three boys were killed. As you might imagine, he suffered deep sadness and even felt as though he no longer wanted to live. But he clung to God's Word and the promise that God comforts us with "songs in the night" as recorded by Job and the psalmist. He knew that even though we may feel overwhelmed by the hardships in life, this truth keeps us singing God's praises.

This beautiful promise became the lyrics of one of my favorite hymns, "He Keeps Me Singing." Verse 4 hints at the tragedy that Luther himself faced that night when all seemed lost in the fire.

It's so encouraging to note that Luther trusted God through his grief and went on to become an evangelist both in the United States and, during World War I, in Belgium, Czechoslovakia, and Russia. He was also blessed with another wife and son. What an amazing encouragement his life and hymn have been to people for generations as they too face the "night seasons" or hardships of life.

# Hymn Study Notes

NAME OF THE HYMN

---

WRITTEN BY

---

YEAR & LANGUAGE THE HYMN WAS WRITTEN

---

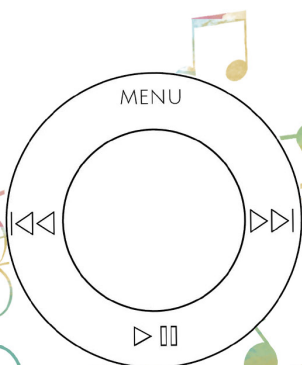

FACTS ABOUT THE AUTHOR



---



---



---



---



---



---

TELL ABOUT THE STORY BEHIND THE HYMN

---

---

---

---

---

---

---



# Bible LESSON

Let's read Psalm 42:8. In the box below, draw the two things God gives us. Be sure to note WHEN He gives these things.



Have you ever felt like the nighttime was scary? Many people are afraid of the darkness because we don't know what's there. This is true about the physical darkness in our room, but also true about the darkness in our heart. When something hard happens in our life, we don't usually know what will happen next and that makes us feel worried and afraid.

Write about a time when you felt this way. What was happening? What did you fear would happen?

---

---

---

---

Now let's look at Psalm 77:1-4. Although many of the psalms were written by David, this one was written by Asaph. How would you describe the feelings he is expressing?

---

---

Read Psalm 77:6 and write two words that the Bible uses to tell us what to do with the song in the night.

1. \_\_\_\_\_

—

2. \_\_\_\_\_

The Bible tells us to remember and meditate (think about) God. That's exactly what the psalmist does here.

In verse 11, what does he remember? \_\_\_\_\_

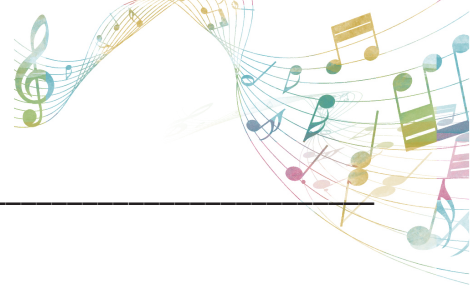

In verse 12, what does he ponder or think about? \_\_\_\_\_

Singing the night song worked, as we can see by his change of attitude.

Look at verses 13 - 15. What are some of the things he remembers about God?

---

---

Now look at verses 16 - 20. What are some of the things he meditates on or thinks about? Draw a few in the box below.

Acts 16:25-34 tells the story of two other people who trusted God by singing hymns in the night. It was actually midnight for Paul and Silas, but what difficult situation was happening in their life while they were singing?

---

Like Paul, Silas, and Asaph, when life is hard we can remember and think about all the good things God has done for us. What song would you sing to God right now? Write a few things below telling what you would want it to say.

---

---

---

---

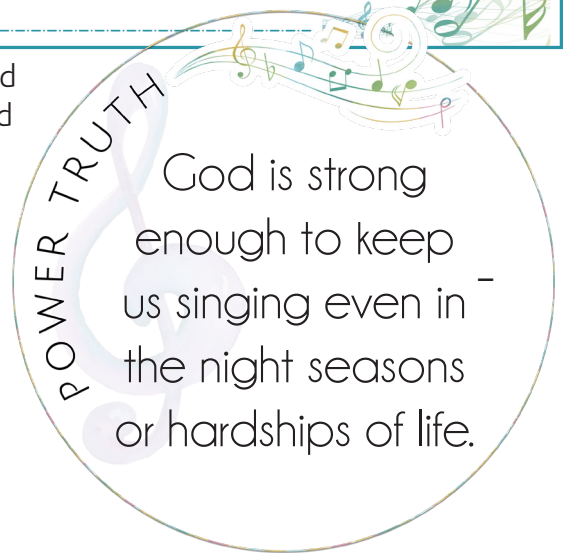





- Practice holding the tin whistle properly
- Practice making loud and soft sounds
- Play the D scale
- Play the hymn

Label the parts of the tin whistle below. Play the D scale on your tin whistle.

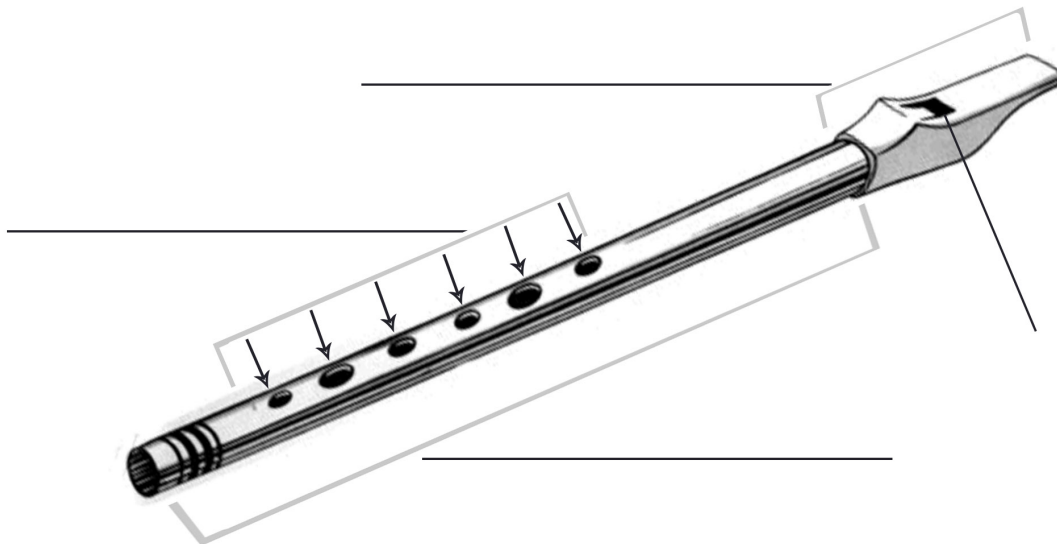

Color in the fingering for the D scale.

D	E	F#	G	A	B	C#	D
<input type="checkbox"/>	<input type="checkbox"/>	<input type="checkbox"/>	<input type="checkbox"/>	<input type="checkbox"/>	<input type="checkbox"/>	<input type="checkbox"/>	<input type="checkbox"/>
<input type="checkbox"/>	<input type="checkbox"/>	<input type="checkbox"/>	<input type="checkbox"/>	<input type="checkbox"/>	<input type="checkbox"/>	<input type="checkbox"/>	<input type="checkbox"/>
<input type="checkbox"/>	<input type="checkbox"/>	<input type="checkbox"/>	<input type="checkbox"/>	<input type="checkbox"/>	<input type="checkbox"/>	<input type="checkbox"/>	<input type="checkbox"/>
<input type="checkbox"/>	<input type="checkbox"/>	<input type="checkbox"/>	<input type="checkbox"/>	<input type="checkbox"/>	<input type="checkbox"/>	<input type="checkbox"/>	<input type="checkbox"/>
<input type="checkbox"/>	<input type="checkbox"/>	<input type="checkbox"/>	<input type="checkbox"/>	<input type="checkbox"/>	<input type="checkbox"/>	<input type="checkbox"/>	<input type="checkbox"/>



# Copywork

There's within my heart a melody  
Jesus whispers sweet and low,  
Fear not, I am with thee, peace, be still,  
In all of life's ebb and flow.  
Jesus, Jesus, Jesus,  
Sweetest Name I know,  
Fills my every longing,  
Keeps me singing as I go.

Handwriting practice lines consisting of solid top and bottom lines with a dashed midline, repeated 10 times.



# MY FAVORITE SONGS

INSTRUCTIONS: On each of the books below write the name of one of the songs you love. At the bottom, write why you love that song.

TITLE



TITLE



TITLE



TITLE



# Extension Activities



Draw a picture of something that you worry about in bed at night. Find a verse in the Bible to help overcome that fear and write it underneath the picture.



Using six notecards or small pieces of paper, draw a picture of your idea of what each of the five stanzas and the chorus of the song should look like. Staple the pages together to make a minibook.



Write 3-5 paragraphs about how Luther Bridgers' life might have been different if the house fire had never happened.



Write a letter to a friend or family member telling them all the things God has done for you and your family. Use proper letter form and address the envelope.



What are some questions you have after reading about Luther Bridgers?





# AMAZING GRACE

## *the story*



Although she died when he was seven, John Newton had a loving and kind mother who was always telling him about God. Together they memorized many verses and songs that comforted him throughout his life, even though it would take many years for him to value them.

After his mother's death, his father took him to sea. He quickly took on the reckless living of a sailor filled with rage, rebellion, and godlessness. As he fell deeper and deeper into sin, he was flogged as a deserter of the navy and held captive on a slave ship where he was nearly starved and poorly treated. His life was filled with dangers, snares, and sin.

One night in 1748, through a brutal storm, he cried to the Lord for deliverance. He later wrote, "The Lord came from on high and delivered me out of deep waters." That day, his life changed. He came to believe in God and throughout the next few years, his faith grew.

For several years he continued to work on slave trade ships, hoping to help the slaves. Upon returning to land, John Newton became one of the most influential evangelical preachers, an active voice against slavery, and the writer of hundreds of hymns. Some of the most well known are "Amazing Grace," "How Sweet the Name of Jesus Sounds," and "There Is a Fountain Filled with Blood."

Written in 1779, "Amazing Grace" was originally titled "Faith's Review and Expectation." This song reflects back on John's past life and his study of 1 Chronicles 17. John Newton knew the secret to true Christianity. None of us is worthy of the loving sacrifice of Jesus. Even while we were still sinners, He came to earth and died to save us. "Amazing Grace" is one of the most beloved hymns of all time and serves as a constant reminder of the most precious truth of the gospel.

# Hymn Study Notes

NAME OF THE HYMN

---

WRITTEN BY

---

YEAR & LANGUAGE THE HYMN WAS WRITTEN

---

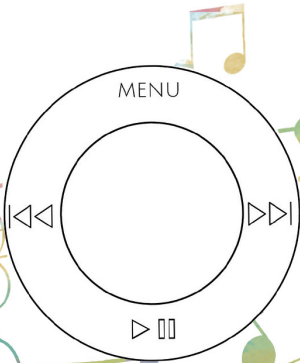

FACTS ABOUT THE AUTHOR



---



---



---



---



---



---

TELL ABOUT THE STORY BEHIND THE HYMN

---

---

---

---

---

---

---



# Bible LESSON

"Amazing Grace" was written by John Newton as he studied 1 Chronicles 17:16 - 17. Let's read that passage. Who is this passage about and what is he doing before the Lord?

---

One thing David knew was how little he was in comparison to God. He knew God was in charge, but he also knew God loved him so much that He offered blessings upon blessings. It's so encouraging that God would offer grace to David even when he made mistakes.

In Romans 3:23 it says \_\_\_\_\_ have sinned and fallen short of the glory of God. That means David, you, me, everyone has sinned! What sins or mistakes have you made today? This week? This year? Write about some of them below.

---

---

---

---

According to Romans 6:23, what is the penalty of our sins? \_\_\_\_\_  
And what does God give us instead? \_\_\_\_\_

## This is grace. Amazing grace.



Romans 5:8 gives us the perfect definition of grace. Write it out below.

---

---

---

So now I must ask you: Do you have the gift of this grace? Have you asked God to forgive you for your sins? If you haven't, and you aren't sure if you have the gift of salvation, talk to your parents today. If you have, write your testimony of how God saved you through Jesus.

We are all sinners, but God's grace is a free gift for anyone willing to accept it.



---

---

---

---

---

---

---

---

---

---

---

---

---

---

---

---

---





- Practice holding the tin whistle properly
- Practice making loud and soft sounds
- Play the D scale
- Play the hymn



Match the musical term to its correct description.

- |                     |  |
|---------------------|--|
| 1. MEASURE (OR BAR) | A. is used to specify how many beats are to be contained in each measure and which note value is equivalent to one beat. |
| 2. TIME SIGNATURE   | B. is a set of five horizontal lines and four spaces that each represent a different musical pitch                       |
| 3. NOTE             | C. space between lines indicating notes to be played   |
| 4. TREBLE CLEF      | D. the staff containing high pitch notes   |
| 5. BASS CLEF        | E. one beat of sound   |
| 6. STAFF            | F. the staff containing low pitch notes  |



# Copywork

Amazing grace! How sweet the sound  
That saved a wretch like me!  
I once was lost, but now am found;  
Was blind, but now I see.  
The Lord has promised good to me,  
His Word my hope secures;  
He will my Shield and Portion be,  
As long as life endures.

Handwriting practice lines consisting of solid top and bottom lines with a dashed midline, repeated 10 times.



# AMAZING GRACE

Unscramble the words below found in this lesson.

1. poeh \_\_\_\_\_
2. disleh \_\_\_\_\_
3. moidpsre \_\_\_\_\_
4. oedeblv \_\_\_\_\_
5. lhecnocisr \_\_\_\_\_
6. mgnaiaz \_\_\_\_\_
7. ecgra \_\_\_\_\_
8. lrsyeav \_\_\_\_\_
9. sliebssgn \_\_\_\_\_
10. hecrtw \_\_\_\_\_
11. vieogrf \_\_\_\_\_
12. hutrt \_\_\_\_\_

## WORD BANK

beloved    grace    wretch    promised    amazing    slavery  
blessings    forgive    truth    hope    shield    chronicles

# Extension Activities



Imagine what a day of life at sea would be like. Write a journal entry about a day in the life of a sailor.



Think about a sin in your life that you are struggling with. Find 3-5 Bible verses that will help you overcome that sin. Write them on note cards and keep them easily available. Ask a parent if you need help finding these verses.



John Newton spoke actively against slavery. Draw a Venn Diagram comparing sin to slavery.



What are some ways you can show grace to a sibling or friend? Write 5-10 ideas and act one out at your first opportunity.



Write an acrostic for the word GRACE, filling in each letter with a truth about God and His grace.





# BLESSED ASSURANCE

## *the story*

Do you have a pen pal? Fanny Crosby did! Frances Ridley Havergal and Fanny Crosby were pen pals even though they never met face to face. Two of the most famous hymn writers in their time, they were good friends and colleagues despite one living in England (Frances) and one in America (Fanny). Frances once wrote this about Fanny:

*Sweet, blind singer over the sea, /  
Tuneful and jubilant! How can it be, /  
That the songs of gladness, which float so far, / As if  
they fell from the evening star /  
Are the notes of one who may never see, / Visible Music  
of flower and tree..... /  
Oh, her heart can see, her heart can see! / And its sight  
is strong and swift and free.....*



Another of Fanny's closest friends was Phoebe Knapp. Although Fanny worked at a rescue mission in the slums of Manhattan, Phoebe was wealthy and lived in a mansion in Brooklyn. Phoebe dressed extravagantly in fancy dresses and diamond tiaras. Her music consisted of the finest instruments in the country, and Fanny visited her quite often.

In 1873, when Fanny was staying in her mansion, Phoebe had a tune she wanted to play for Fanny. After walking to the music room, Phoebe sat at the piano and played her song. Once the piece was over, the blind hymn writer jumped up and exclaimed, "Why, that says 'Blessed Assurance!'" As she composed the words, a great hymn was born.

It's hard to imagine writing hymns as a blind person, but Fanny Crosby wrote somewhere between 5,500 and 9,000 hymns. She used many pseudonyms (or fake names) because she wanted God to receive the glory instead of taking it herself. Today, many of our most beloved hymns are credited to her.

Her story is one of praising her Savior all the days of her life. Despite the hardship of being blind, she was nothing but thankful, dedicating her life to creating music to help people face difficulties with faith and trust. What a beautiful encouragement we find in both Fanny Crosby and this hymn, "Blessed Assurance." What is YOUR story?

# Hymn Study Notes

NAME OF THE HYMN

---

WRITTEN BY

---

YEAR & LANGUAGE THE HYMN WAS WRITTEN

---

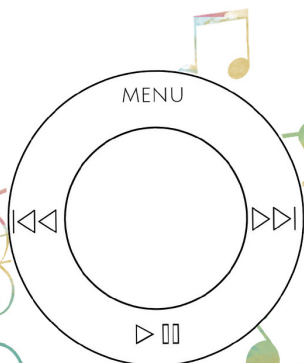

FACTS ABOUT THE AUTHOR



---



---



---



---



---



---

TELL ABOUT THE STORY BEHIND THE HYMN

---

---

---

---

---

---

---



# Bible LESSON

You might not be blind like Fanny Crosby, but I know you have struggles. Many people have physical limitations and health issues that keep them from living life exactly like others. But even if it's not a physical thing, we all have weaknesses.

Maybe math is hard for you. Maybe it's hard to make friends. Maybe reading makes you want to cry. Or maybe you aren't very good at sports. The truth is, while we don't all have physical limitations like Fanny, we all have strengths and we all have weaknesses. The physical things are beyond our control, but both physical limitations and weaknesses are things we have to keep working at, despite the fact it may never be easy.

Let's read 2 Corinthians 12:7. Who is this passage about and what was his problem or weakness?

---

---

Although he asked God to take his problem away, what did God say? (verse 9)

Instead of taking it away, God made a promise to Paul that is very encouraging for us too. Read verse 9 carefully again. What does God do with our weaknesses?

---

---

This is a truth we can't afford to miss in life. It's where we are the weakest that God shows His glory and mercy to others. In fact, if we weren't weak, we would just get in the way with our pride and arrogance.

So let's rethink the way you feel about your struggles. Start by listing them below.

WEAKNESSES	BLESSINGS
<hr/>	<hr/>
<hr/>	<hr/>
<hr/>	<hr/>
<hr/>	<hr/>
<hr/>	<hr/>
<hr/>	<hr/>



Ok, now rewrite your story. Look at the chorus of "Blessed Assurance":

*This is my story, this is my song.  
Praising my Savior all the day long*

Go back up to that chart and write a blessing next to each weakness you listed. How can God use this? How has He already used it? In what ways can you encourage others with this?

Now write a prayer to God thanking Him for the blessing of weaknesses.

---

---

---

---



---

---

---

Finish out today by writing the words of 2 Corinthians 12:10.

---

---

---





---







Go back and circle WHO this is for then underline WHAT you will do. Repeat the last phrase out loud to yourself until you have it memorized.

*For when I am weak, then I am strong!*



















-  Practice holding the tin whistle properly
-  Practice making loud and soft sounds
-  Play the D scale
-  Play the hymn

NAME OF NOTE	whole	half	quarter	eighth	sixteenth	dotted half note	dotted quarter note
SYMBOLS							
BEATS	4	2	1	1/2	1/4	3	1 1/2

INSTRUCTIONS: Write the correct beat value of each note below.

 _____	 _____	 _____	 _____	 _____
 _____	 _____	 _____	 _____	 _____
 _____	 _____	 _____	 _____	 _____



# Copywork

Perfect submission, all is at rest,  
I in my Savior am happy and blessed,  
Watching and waiting, looking above,  
Filled with His goodness, lost in His love.  
This is my story, this is my song,  
Praising my Savior all the day long;  
This is my story, this is my song,  
Praising my Savior all the day long.

Handwriting practice lines consisting of solid top and bottom lines with a dashed midline, repeated 10 times.



# BLESSED ASSURANCE

## *crossword*

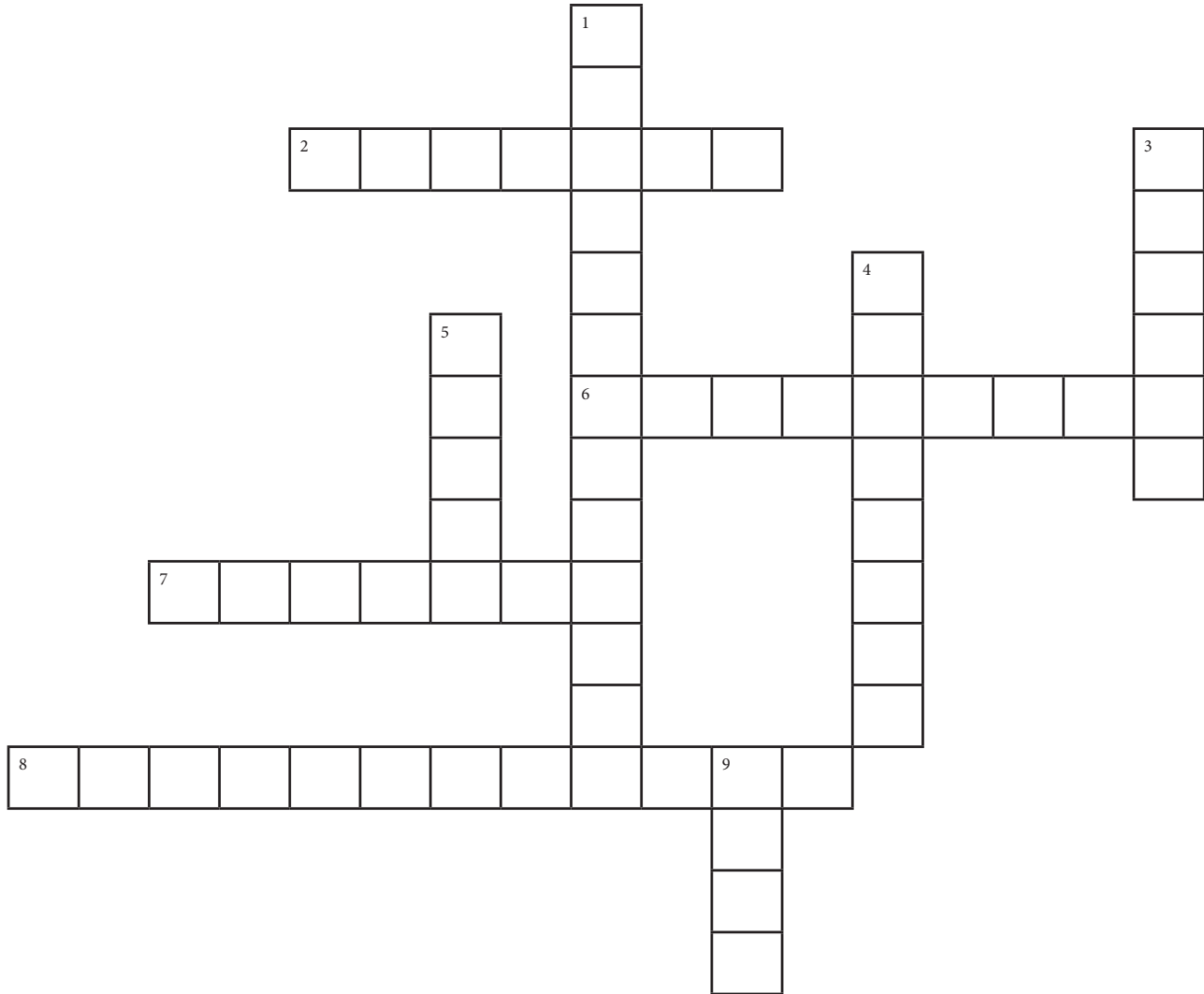

### DOWN

1. Where did Fanny work?
3. For when I am weak, then I am \_\_\_\_\_
4. From the song " \_\_\_\_\_ my Saviour,  
all the day long"
5. Fanny Crosby's gift
9. Who had a problem in 2 Corinthians 12:7

### ACROSS

2. From the song "I in my Saviour am happy and  
\_\_\_\_\_"
6. In what city was her work located?
7. Fanny Crosby's pen pal's first name
8. Who composed the music to Blessed Assurance

# Extension Activities



Learn about the life of Fanny Crosby. Write or draw 5 facts you learned.



Choose 5 famous people in history and find out a weakness or hardship each of them had. Write a paragraph for each about the hardship and how it strengthened them.



Fanny Crosby used many pseudonyms; research to find 3-5 songs that she wrote using different names.



Use a cloth or blindfold to cover your eyes. Once blindfolded try doing something you normally do easily: get a drink of water, brush your teeth, wash your hands.



Research the life of Fanny Crosby and write a report.





# TAKE MY LIFE AND LET IT BE *the story*

Remember Fanny Crosby's pen pal? This hymn was written by Fanny's beloved friend and fellow hymnist, Frances Havergal. Frances had served the Lord for years, but she felt that something was missing in her walk with God. One December day in 1873 she received a book called *All for Jesus*. This little book stressed the importance of giving your all to Christ and making your life all about Him. Soon after reading that book, she consecrated herself completely to Christ, just as the book had taught.

A few months later, in 1874, she found herself staying in a house with ten other people. Some were not fully committed to Christ, others weren't even saved. Frances asked God to help her lead them to recommit or lead them to salvation. "Lord," she prayed, "Give me all this house." She witnessed to all throughout her stay, and by the end of it, all in the house were fully committed to God.

She was so excited that she couldn't sleep on the last night of her stay, so she began to write "Take My Life and Let it Be." In the years that followed, she often used this as a devotional, especially on the anniversary of her commitment to fully live for Christ.

One time while pondering these words, "Take my voice and let me sing, always only for my King," she decided that she should stop singing in secular concerts. Her beautiful voice was quite popular, but she dedicated her voice only to the Lord.

A different time, she was praying over the verse that says, "Take my silver and my gold, not a mite would I withhold." She had accumulated a great deal of jewelry, but now she felt she should donate it to the Church Missionary Society. She retained only a brooch and a special locket. She later said that she had never packed a box as happily as she had that one.

What Frances found is true for you, too. Giving your life fully to God might require giving up some things, but it will always bring great joy and happiness as it's the only thing worth devoting yourself to. Have you given yourself to God?



# Hymn Study Notes

NAME OF THE HYMN

---

WRITTEN BY

---

YEAR & LANGUAGE THE HYMN WAS WRITTEN

---

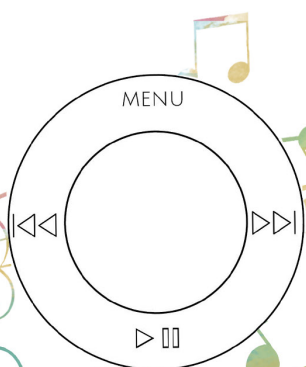

FACTS ABOUT THE AUTHOR



---



---



---



---



---



---

TELL ABOUT THE STORY BEHIND THE HYMN

---

---

---

---

---

---

---



# Bible LESSON

A few hymns ago we studied God's grace and talked about the forgiveness of our sins, and salvation offered through Jesus. I pray you've accepted that gift and I want to remind you to ask your parents if you have any questions or confusion about it.

Today we are going to take our commitment to Christ one step further. Have you ever considered that just believing in God might not be enough?

Let's read James 2:19 and see the mistake that others made. Who else believes in God?

---

This verse helps us see that believing God exists is not really faith. Faith is trusting Him to save us. It's trusting Him with our life. That's what Frances Havergal learned that day and what prompted her to write the words of this beautiful hymn.

You see, if we really do see our sin for what it is, and we trust God to save us, we can't help but want to give our lives to Him alone!

Paul felt the same way. Let's read about that in Philippians 3:8. Why is everything else counted as loss?

---

---

It's not that all things here on earth are so bad, only that knowing Jesus is SO MUCH more valuable!

One of the things Frances realized was the importance of giving her talents to the Lord before giving them or using them elsewhere. Have you ever thought about that?

1 Peter 4:10 tells us how God wants us to use our gifts and talents. What does it say?

---

---





Read through the lyrics of this hymn and then make a list of your talents, gifts, blessings, and strengths in the first column below. Think hard about all of the things God has given you and the ways He has made you special.

TALENT	USING THEM FOR GOD
_____	_____
_____	_____
_____	_____
_____	_____
_____	_____
_____	_____

Remember to include your love for others, your feet, hands, and your mind as the hymn mentions. Even if you don't know what your talents are, we all can use these things to serve the Lord!

Now let's think of some ways you can use these things for God. How can you use them to help or serve? How can you use them to tell others about Him? Fill in the chart as you think of things.

As we close our lesson today, consider making a commitment to consecrate or dedicate your life to God, giving Him your time, talents, gifts, treasures... everything. Pray and ask Him to help you. Record your commitment below, if you make one, or just record your prayer asking God to help you have this desire.

---



---



---



---



---





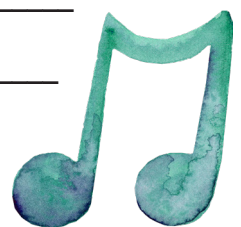





---











-  Practice holding the tin whistle properly
-  Practice making loud and soft sounds
-  Play the D scale
-  Play the hymn

NAME OF REST	whole	half	quarter	eighth	sixteenth
SYMBOLS					
BEATS	4	2	1	1/2	1/4

INSTRUCTIONS: Write the correct beat value of each rest below.

SYMBOLS					
NAME					
BEAT					



# Copywork

Take my life and let it be  
Consecrated, Lord, to Thee.  
Take my moments and my days,  
Let them flow in endless praise.  
Take my will and make it Thine,  
It shall be no longer mine.  
Take my heart—it is Thine own,  
It shall be Thy royal throne.

Handwriting practice lines consisting of solid top and bottom lines with a dashed midline, repeated 10 times.



# TAKE MY LIFE AND LET IT BE

*word search*

O W  
 B S S P  
 Y E B F X H  
 R R E P D C X E  
 L U E C T S E H V V  
 E S K T X O T J T Y F R  
 W A Z T A D A N M K T M O E  
 E E U V F C E M E C X W I N G S  
 J R A S V F I T N L B E P P M I K S  
 Z T H E W G N D A M A M Q R R M M S I Q  
 G I F T S M M E R I T C Z K T N S O T T  
 X H V K N F D C S T N E M O M R Y C  
 D F R A N C E S H A V E R G A L  
 P Y V Q T S I J T M B L N M  
 R N N S N O E V N N S Z  
 A Q C O N C C N D N  
 I C C A I J V C  
 S K R O O W  
 E Y V P  
 O X

FRANCES HAVERGAL  
 JEWELRY  
 DEDICATE  
 MISSIONARY

CONSECRATED  
 ENDLESS  
 TREASURES  
 HYMNIST

VOICE  
 TALENTS  
 PRAISE  
 CONCERT

GIFTS  
 SERVE  
 MOMENTS  
 COMMITTED

# Extension Activities



Read the story of Eric Liddell, a missionary who had to make a difficult choice about when to use his talents, too. Report on your findings.



Make a coupon book for members of your family of things that you can do to serve them. Make it specific to their needs if possible: help sibling with homework, take out the trash, vacuuming car, taking care of sibling's pet, etc.



Make a list of people you find in the Bible who started serving God at a young age.



Choose a missionary family that your church supports and get to know more about them. Write letters to them, pray for them, ask questions about their ministry.



Next time you are at a park or playground, take along a trash bag and serve the community by picking up trash you find (consider using gloves).





## WHAT A FRIEND WE HAVE IN JESUS *the story*

Shocked, Joseph Scriven watched as his fiancée drowned in the lake. The wedding planned for the next day would no longer take place. Only 25 years old and reeling in pain, he left his mother behind in Dublin, Ireland and immigrated to Canada.

Ten years later, in 1855, he heard that his mother was facing a crisis and sent her a poem to comfort her. Unknown to him at the time, she gave it to a friend who published it anonymously. The comfort offered in that little poem quickly became a popular hymn called "What A Friend We Have in Jesus."

The faith required to write that poem was again tested when tragedy struck a second time, taking yet another fiancée before the wedding. Understandably, Joseph poured himself into the ministry in an attempt to escape the pain. He preached among the Baptists and did charity work for the Plymouth Brethren.

He lived a simple life, chopping wood for widows and giving to those in need. Until a short time before his death, it was not known that he had a poetic gift. A neighbor, sitting up with him in his illness, happened upon a manuscript copy of "What a Friend We Have in Jesus." Reading it with great delight and questioning Joseph about it, he said that he had composed it for his mother, to comfort her in a time of special sorrow, not intending that anyone else should see it. Some time later, when another neighbor asked him if he had indeed composed the hymn, his reply was, "The Lord and I did it between us."

Joseph had learned something every Christian needs to know. Even when life is full of grief and sin, we have the wonderful privilege of carrying all of that to Jesus in prayer. God brings healing to our hearts through prayer, just like He did for Joseph Scriven.



# Hymn Study Notes

NAME OF THE HYMN

---

WRITTEN BY

---

YEAR & LANGUAGE THE HYMN WAS WRITTEN

---

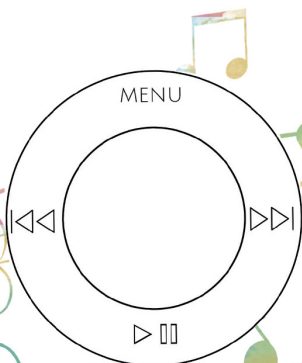

FACTS ABOUT THE AUTHOR



---



---



---



---



---



---

TELL ABOUT THE STORY BEHIND THE HYMN

---

---

---

---

---

---

---



# Bible LESSON

In today's Bible lesson, let's consider the power of prayer. Look at the first verse of "What a Friend We Have in Jesus." What does the hymn writer tell us we will forfeit if we don't carry everything to God in prayer?

---

---

---

---



Forfeit means to give something up. That means if we don't give all of our sins, grief, troubles, and temptations to God in prayer, we GIVE UP the peace He offers us. There is a verse in the Bible that tells us all about this truth.

Let's read Philippians 4:6-7. Instead of being anxious (or worried) about something, this verse tells us to do what?

---

Praying is a command God gives us to help us. We are going to see exactly what the benefits are in the next verse, but first, there is one condition that we are supposed to pray with. What does verse 6 tell us to do while we are praying?

---

Have you ever tried to thank God for something you didn't really like? I sure have and it's very hard, but it's also very important. God tells us to pray when we are worried about something, but He also tells us to pray with thanksgiving. That means we don't pray words that are full of worry and dread, but words that are full of trust and thankfulness because we KNOW God will take care of us.



Do you know we have that promise? Even when things seem really bad, like they did for Joseph Scriven when he lost two potential wives, God is working things out. Read Romans 8:28. Write one word that describes HOW God works things out. (Hint: it's the opposite of bad.) \_\_\_\_\_

It's incredible to think that God works ALL things for our good. Even death, pain, bullies, accidents, broken legs, cancer... all things work for our good.

Let's go back to Philippians 4 and read verse 7 now. After we have given our requests to God with thanksgiving, what will God give us?

---

---

I love how this verse says the peace will transcend all understanding. That means we will hardly be able to believe it. It won't even seem possible, but God will give us peace even when life doesn't seem so good.

Take a few minutes and pray to God, thanking Him for this promise. Ask Him to show you ways He has worked things out for your good. Write those things below. If you can't think of any, ask your parents for help. This is an important exercise in helping us understand the wonderful promises of our Savior.

---

---

---

---

---

---

---

---







- Practice holding the tin whistle properly
- Practice making loud and soft sounds
- Play the D scale
- Play the hymn

A *scale* is any set of musical notes ordered by pitch. A scale ordered by increasing pitch is an ascending scale, a scale ordered by decreasing pitch is a descending scale.

Key Of D Major

Key of D Major

D E F# G A B C# D E F# G A B C# D



# Copywork

What a friend we have in Jesus,  
All our sins and griefs to bear!  
What a privilege to carry  
Everything to God in prayer!  
Oh, what peace we often forfeit,  
Oh, what needless pain we bear,  
All because we do not carry  
Everything to God in prayer!

Handwriting practice lines consisting of multiple sets of solid top and bottom lines with a dashed midline.



# VOCABULARY FUN

Write or draw a definition for each word.

CANADA

CHARITY

FIANCE

FORFEIT

IRELAND

PRIVILEGE

# Extension Activities



Write an acrostic with the word FRIEND. After each letter write an attribute of God.



Think of something in your life that has made you sad. Write a letter about it and how it made you feel as if you are sending it to your best friend. Read it out loud to Jesus.



Find 5 adjectives in the story and write down the antonym for each of the words.



Do you know some people who have gone through or are going through difficult times? Make a list of them and write down how you might be able to pray for them.



Write a short story about someone who gave up something to help someone else.





# A MIGHTY FORTRESS IS OUR GOD

*the story*

Martin Luther is well known for many different things, but most notably for his rejection of the practices of the Roman Catholic Church. He was a great reformer, Bible translator, political leader, fiery preacher, and theologian, but also a renowned musician. He grew up in an area of Germany known for music, and it was an integral part of his life. During his childhood, he listened to his mother sing, joined a boy's choir, and played the recorder among many other musical ventures.



Martin desired to restore music to the German church when the Reformation started. He worked with a number of other musicians to revive congregational singing in the churches, writing as many as 24 hymns and accompanying them with the lute. He was passionate about music and wanted to bring it back to its intended purpose of praising God in church worship, school, home and even public places.

Once, Martin wrote in the foreword of a book: "Next to the Word of God, the noble art of music is the greatest treasure in the world. It controls our thoughts, minds, hearts, and spirits..." This belief couldn't be more true today! Music has a beautiful way of helping us focus on God's truth, but it can also take control of our emotions, making us feel happy or sad.

Written in 1529, Martin Luther's most famous hymn is "*Ein' feste Burg ist unser Gott*" or "A Mighty Fortress Is Our God." It is based on Psalm 46 and meant to illustrate our battle with Satan and encourage us to fight the good fight. During a hard time, Martin would say to his associate, "Come, Philipp, let us sing the 46th Psalm."

Because the original German is so vivid, this is a particularly hard hymn to translate. There are at least eighty versions available in English. The most popular one was translated by Frederic Henry Hodge and is found in most hymnals today.

# Hymn Study Notes

NAME OF THE HYMN

---

WRITTEN BY

---

YEAR & LANGUAGE THE HYMN WAS WRITTEN

---

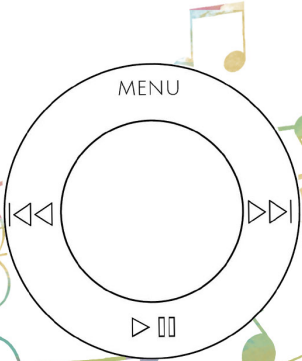

FACTS ABOUT THE AUTHOR



---



---



---



---



---



---

TELL ABOUT THE STORY BEHIND THE HYMN

---

---

---

---

---

---

---



# Bible LESSON

Using a dictionary, define the word "fortress" below.

---

A fortress has been used throughout history to protect people from their enemies. It's a building or a group of buildings that are built up to defend and keep those inside from being hurt by the things on the outside.

This hymn is one of the most beloved hymns of all time because of the reminder that God is our fortress. He is our protector, defender, and shield. He takes care of His people.

Do you know what God protects us from? The Bible identifies three enemies we battle with. Let's find the first one in 1 John 2:15-17. In this passage we see that all that is in the \_\_\_\_\_ is not of the Father.

That means the things of the world work against us, often keeping us from doing right. It's important to note that we aren't called to hate the world or the people in the world. Quite the opposite. We are to love them. This verse just reminds us that the things of the world are not of God, meaning we may find ourselves needing to stay away from some of the things the rest of the world does.

What things does your family do differently than other families you know? Why? If you aren't sure, ask your parents to talk with you about this.

---

---

Our second enemy is found in Romans 7:18. After reading this verse, what enemy do you find here? \_\_\_\_\_

Have you ever thought of yourself as being your own enemy? The Bible says the flesh or the sinfulness inside of you works against you. This is the part of you that does the wrong thing even when you want to do the right thing. It's selfish and doesn't seek the good of others first.

The final enemy is found in John 10:10. Who is it? \_\_\_\_\_

What does he want to do to us? \_\_\_\_\_

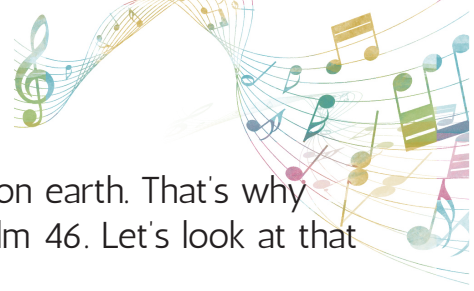

The world, the flesh (ourselves), and the Devil are all against us here on earth. That's why we need a fortress, a protector. This hymn was written based on Psalm 46. Let's look at that passage now.

Read Psalm 46:1 and write it below.

---

---

Draw the scene described in verses 2 and 3.



Psalm 46:5 is one of my favorite verses. Write it below.

---

---

Finish your study today by writing a prayer to the Lord, thanking Him and telling Him how you feel about His protection and promises found here in Psalm 46.

---

---

---

---





---

















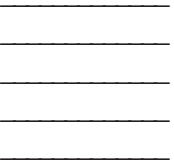

# Music THEORY

-  Practice holding the tin whistle properly
-  Practice making loud and soft sounds
-  Play the D scale
-  Play the hymn

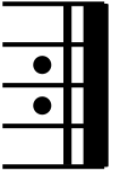
Draw in the missing pictures.

Quarter Note 	Quarter Note	Quarter Rest 	Quarter Rest	Eighth Note 	Eighth Note
Double Eighth Note 	Double Eighth Note	Half Note 	Half Note	Full Rest 	Full Rest
Staff 	Staff	Bass Clef 	Bass Clef	Sixteenth Note 	Sixteenth Note
Whole Rest 	Whole Rest	Final Double Bar Line 	Final Double Bar Line	Treble Clef 	Treble Clef



# Copywork

A mighty fortress is our God, a bulwark never failing;  
Our helper He, amid the flood of mortal ills prevailing:  
For still our ancient foe doth seek to work us woe;  
His craft and pow'r are great, and, armed with cruel hate,  
On earth is not his equal.

Handwriting practice lines consisting of multiple sets of three horizontal lines (top, middle dashed, bottom) for copying the text above.



# VOCABULARY FUN

In the boxes below define each word by either writing or drawing.

MIGHTY

FORTRESS



FOE



ANCIENT

MORTAL



# Extension Activities



If you have a military fort or army base in your local area, take a field trip there. Study how well it was built to protect.



Music can control our emotions. Think about and write out a few lines of a song that makes you feel happy or joyful in the Lord.



Have a parent help you find and listen online to a hymn sung in German.



Learn about the life of Martin Luther and write a journal entry about what a day in the life of Martin Luther might have been like.



Draw a picture of what you think a strong and mighty fortress might look like, name some parts of the fortress after attributes of God as our fortress.





# IT IS WELL WITH MY SOUL

*the story*

The great Chicago fire of 1871 consumed much of the city, leaving people homeless, desperate, and broke. Horatio G. Spafford was a respected attorney who was heavily invested in real estate. Not only did he lose a fortune in the fire, he was consumed with helping others left without a place to live. In the whirlwind of this tragedy, his only son died of scarlet fever at the age of four.

Two years later, he had planned to take his wife and daughters to Europe for some evangelistic meetings, as well as vacation. When an urgent matter kept Horatio from leaving, he sent his wife and four daughters ahead aboard the French liner *Ville Du Havre*.

It was November 22, 1873. All the passengers were jolted when the *Ville Du Havre* collided with an iron sailing vessel. Water flowed into the boat faster than they could have imagined. Screaming, each passenger fought for his own survival. They clung to anything that would keep them from drowning in the icy water. Within two hours, the *Ville Du Havre* was completely submerged in the water. Out of 274 passengers, only forty seven survived.

His wife clung to debris in the icy waters, but none of Horatio's daughters survived. When his wife and the other survivors finally arrived in Wales, she sent her husband these words, "Saved alone."

Immediately, Horatio boarded a ship to meet his wife. One cold December night during the voyage, the captain called him up on deck. "I believe this is where the *Ville Du Havre* sunk," he said.

As you might imagine, Horatio could not sleep that night. In the quiet darkness of his cabin he said to himself, "It is well; the will of God be done." These words inspired him to later write the famous hymn "It Is Well With My Soul" and have inspired countless Christians as they have faced the tragedy of death or hardships in this life. Even when everything we love is lost, God's will is still good. We still can have peace in our souls.



# Hymn Study Notes

NAME OF THE HYMN

---

WRITTEN BY

---

YEAR & LANGUAGE THE HYMN WAS WRITTEN

---

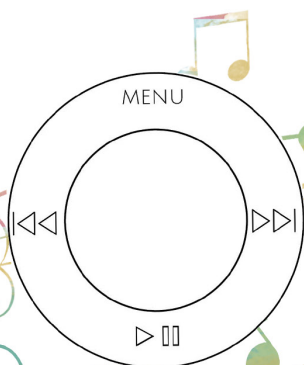

FACTS ABOUT THE AUTHOR



---



---



---



---



---



---

TELL ABOUT THE STORY BEHIND THE HYMN

---

---

---

---

---

---

---



# Bible LESSON

It's hard to imagine having a response like Mr. Spafford did when he was faced with the death of his children. But he knew the same truth that Job did. If you've never read about Job before, let me show you the quick version of his story.

Read Job 1:13-19. List the things that Job lost.



\_\_\_\_\_ v. 14-15



\_\_\_\_\_ v. 16



\_\_\_\_\_ v. 17



\_\_\_\_\_ v. 18-19

Can you imagine losing all of that in one day? Job lost his children, his employees, his business (livelihood), and much of his food. In those days, this really was devastating. But his response was much like Mr. Spafford's.

Read Job 1:20-21. In your own words, write what Job did.

---

---

---

The words of this hymn would have been the same words of Job's heart. It is well. Even though you have taken my children and nearly everything I have, you are still good, Lord. I must admit this is a hard thing to say, but it's true.

David expressed the same trust in God when he wrote Psalm 62:5-6. Let's read those verses now.

Where does our hope come from? \_\_\_\_\_

Sometimes we are tempted to think hope comes from happiness or happy things happening in our lives, but that is absolutely not true. Our hope comes from the Lord.

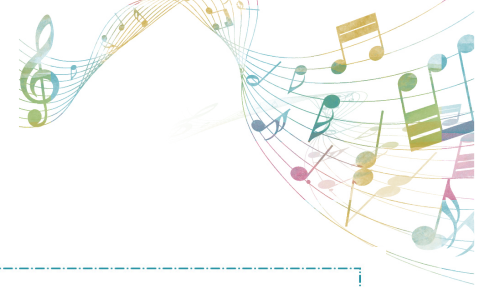

In the box below, draw a description for the Lord from verse 6.

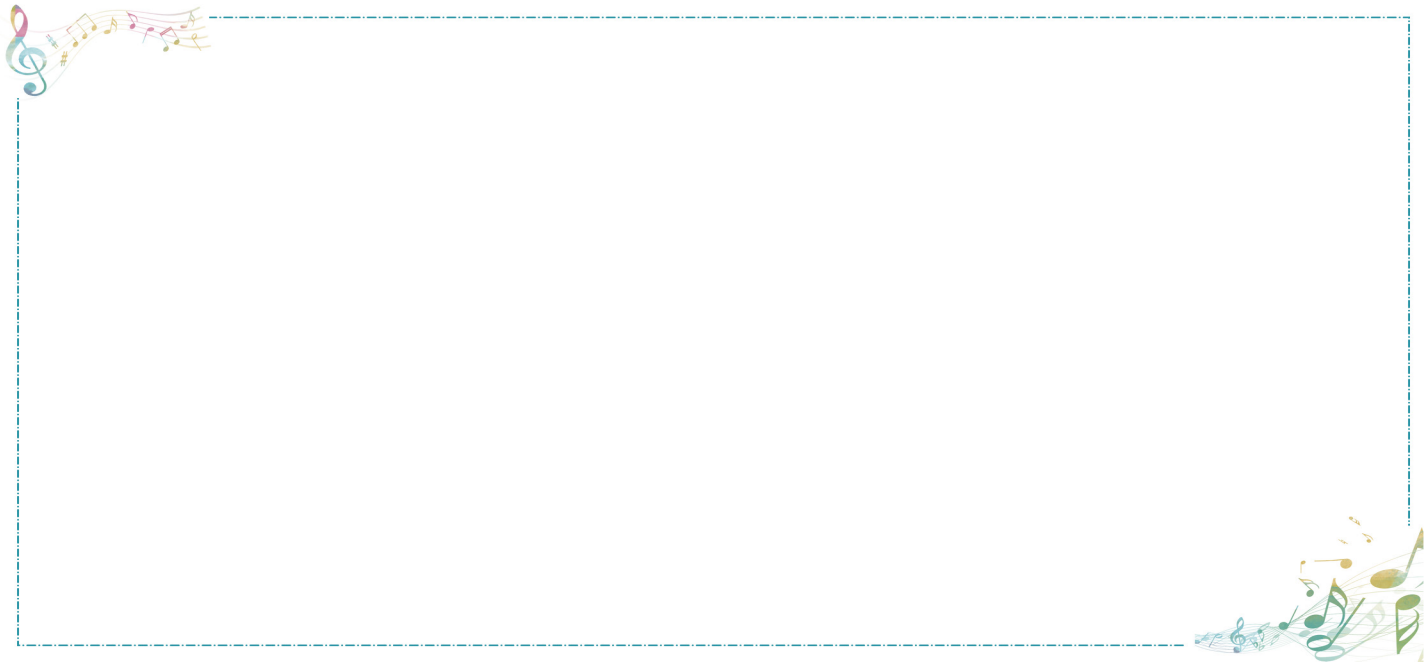

I love that we are again seeing how God is our fortress. He protects us from our enemies as we saw when we studied "A Mighty Fortress Is Our God," and He also protects us from sadness, despair, and hopelessness. We know that even when life is hard, God gives us strength.

My absolute favorite part of these verses is the very last phrase of verse 6. Fill it in below.

**I** \_\_\_\_\_

This is the truth Job, Mr. Spafford, and David were leaning on. Even when life's sorrows are as large as the sea, our souls will never be shaken from within the loving protection of God.

Write a prayer to Him today, expressing how you feel about these truths.

\_\_\_\_\_

\_\_\_\_\_

\_\_\_\_\_

\_\_\_\_\_

\_\_\_\_\_

\_\_\_\_\_

\_\_\_\_\_

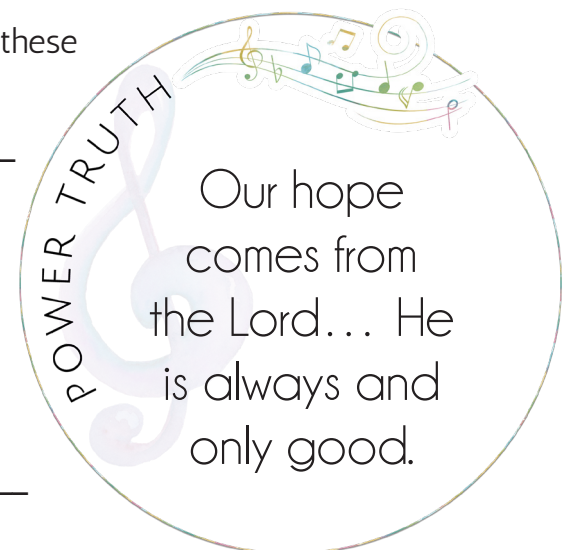





- Practice holding the tin whistle properly
- Practice making loud and soft sounds
- Play the D scale
- Play the hymn

*Dynamics* tell you how loud or soft to play the music.

Is this dynamic a LOUD or SOFT dynamic? Circle your answer.

- |    |           |      |      |
|----|-----------|------|------|
| 1. | <i>f</i>  | LOUD | SOFT |
| 2. | <i>p</i>  | LOUD | SOFT |
| 3. | <i>pp</i> | LOUD | SOFT |
| 4. | <i>mf</i> | LOUD | SOFT |

Sort all the dynamics from softest to loudest and write their meanings underneath the chart.

*mf f mp pp ff p*

<input style="width: 50px; height: 50px;" type="text"/>	<input style="width: 50px; height: 50px;" type="text"/>	<input style="width: 50px; height: 50px;" type="text"/>	<input style="width: 50px; height: 50px;" type="text"/>	<input style="width: 50px; height: 50px;" type="text"/>	<input style="width: 50px; height: 50px;" type="text"/>
<hr style="width: 100%;"/>	<hr style="width: 100%;"/>	<hr style="width: 100%;"/>	<hr style="width: 100%;"/>	<hr style="width: 100%;"/>	<hr style="width: 100%;"/>



# Copywork

When peace, like a river, attendeth my way,  
When sorrows like sea billows roll;  
Whatever my lot, Thou hast taught me to say,  
It is well, it is well with my soul.  
Though Satan should buffet, though trials should come,  
Let this blest assurance control,  
That Christ hath regarded my helpless estate,  
And hath shed His own blood for my soul.

Handwriting practice lines consisting of solid top and bottom lines with a dashed midline, repeated 10 times.

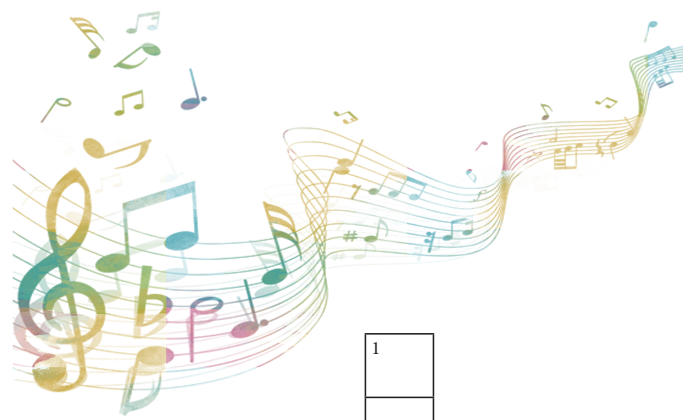

# IT IS WELL WITH MY SOUL

## *crossword*

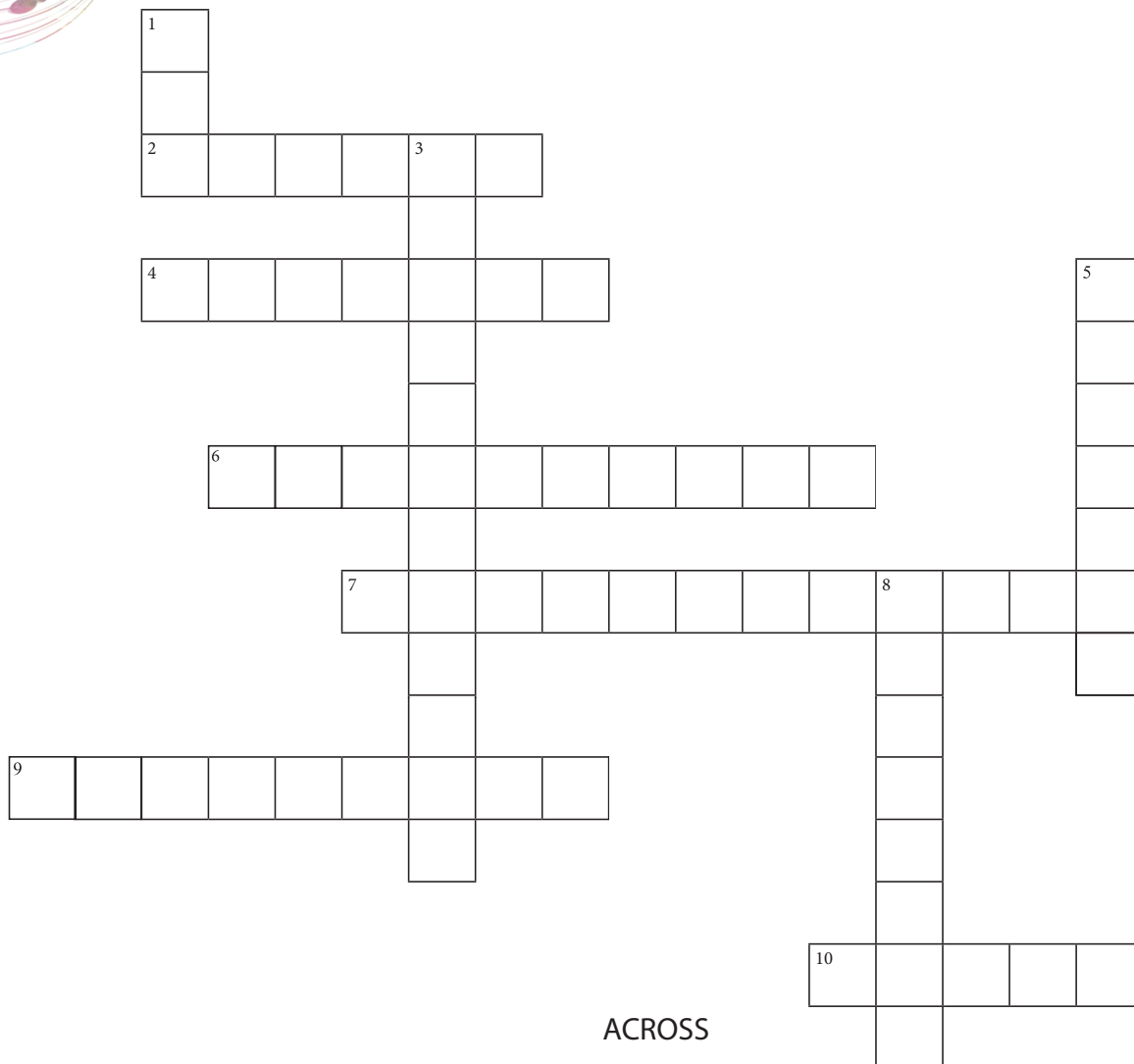

### DOWN

1. Who lost his children, employees and livelihood
3. What type of meetings were they planning to go to in Europe?
5. In Job 1:21, Job said " \_\_\_\_\_ be the name of the Lord"
8. What was Horatio Spafford's occupation?

### ACROSS

2. From the song "Though Satan should \_\_\_\_\_, though trials should come"
4. Where was the great fire in 1871?
6. What words did Mr. Spafford's wife send to him when the ship sank?
7. What was the name of the ship his family took to Europe?
9. In Psalm 62:6, David said "He only is my rock and my \_\_\_\_\_."
10. From the song "When \_\_\_\_\_ like a river attendeth my way."

# Extension Activities



What questions do you have about Horatio Spafford's life? Research to see if you can find the answers.



Write a newspaper headline about the great fire in Chicago in 1871 or the sinking of the *Ville Du Havre*.



Make a Venn Diagram about the lives, faith, and reactions to crisis of Job and Horatio Spafford.



Call your church and ask for the names of members who have recently lost family members. Make these people a card or offer to help with some of their needs.



Do ships sink today? Do some research and learn about the measures most ships have in place to keep them from sinking.





# I HAVE DECIDED TO FOLLOW JESUS *the story*

"I Have Decided To Follow Jesus" is an old Indian folk song. The story of how this hymn was written, when it was written, and who wrote it isn't completely known. However, the most widely accepted story is about a brand new Christian with great courage that you are going to want to hear.

In the mid 1800's, many missionaries came to Northeast India hoping to spread the gospel, but the task proved to be very difficult because of the vast cultural differences. At this time, India was not separated into states like it is now, but instead into regions filled with many different tribes.

One particular missionary from Wales had suffered severely from persecution, but he would not give up in his pursuit to tell the people about Jesus. Finally, he succeeded in converting one man and his family to Christianity in a region called Assam.

Upon hearing this, the tribe's chief was enraged. He commanded that the new Christians (a young couple with 2 children) be brought before him. When they were brought, the chief offered them a chance to recant their belief and live. The man's response was "I have decided to follow Jesus, no turning back, no turning back."

Angry at his unwilling response, the chief ordered his bowman to shoot the children. "I will give you a chance to save yourself and your wife," said the chief. Once again the man said, "Though none go with me, still I will follow, no turning back, no turning back."

Furiously, the chief demanded that the man's wife be shot. As the last one standing, the chief once again gave him a chance to deny his faith, and once again the man claimed boldly, "The world behind me, the cross before me, no turning back, no turning back."

The man was killed in the same manner as the rest of his family. But all was not lost. The faith of this family deeply moved the chief. He wondered, "Why should this man, his wife, and two children die for a Man who lived in a far-away land on another continent some 2,000 years ago? There must be some supernatural power behind the family, and I too want that supernatural power."

The faith of this new Christian and the resolve of the missionaries who faced much persecution was not wasted as the chief and his entire village believed in God as a result.

Can you imagine having that kind of courage to stand up for what you believe? The words of this hymn have encouraged Christians for hundreds of years as we all find the courage to follow Jesus, even if no one else goes with us.



# Hymn Study Notes

NAME OF THE HYMN

---

WRITTEN BY

---

YEAR & LANGUAGE THE HYMN WAS WRITTEN

---

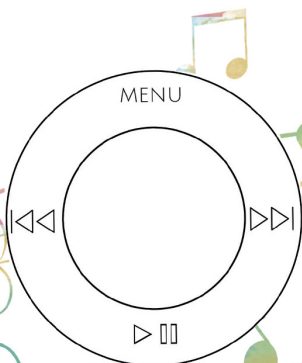

FACTS ABOUT THE AUTHOR



---



---



---



---



---



---

TELL ABOUT THE STORY BEHIND THE HYMN

---

---

---

---

---

---

---



# Bible LESSON

When I was a little girl I wanted to become a Christian, but I didn't quite understand until I was older that following Christ would be so hard. I have always wondered if Jesus's disciples felt the same way. They followed Him willingly, but did they really know what they were getting into?

Let's read Matthew 10:16 - 22. What are some of the ways Jesus tells the disciples they will be persecuted?

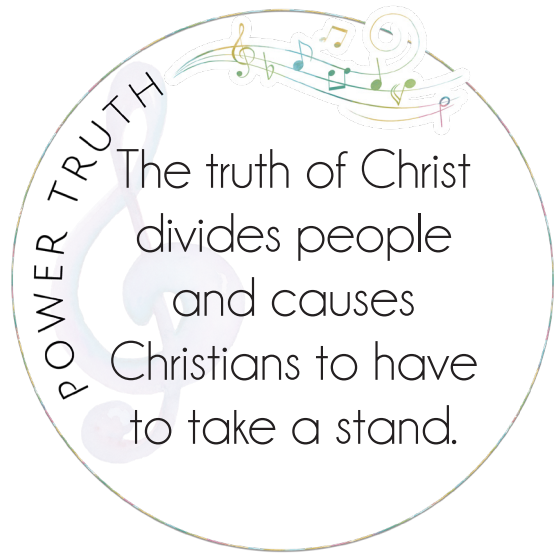

---

---

---

This passage ends with Jesus promising that Christians will be hated for His name's sake.

Read 2 Timothy 3:12. Who does this passage say will be persecuted?

---

Jesus's disciples were beaten, jailed, accused, killed, and more. Since the days of the early church, Christians have faced the same type of persecution, suffering job loss, bullying, violence, hatred, and yes, even murder.

The truth of Christ divides people and causes Christians to have to take a stand. Let's read Luke 9:23 - 27 for more encouragement. After reading, write how these verses help you to have courage.

---

---

---



Now let's make this lesson really personal. Do you think you are standing up for Jesus the way that family did when the chief called them to stand before him? Do those around you know you are a Christian by the choices you make and the things you stay away from?

In the space below, write some things you've chosen either NOT to do or chosen to commit to do because you are a Christian, even if it means those around you make fun of you or hate you. For example, our family goes to church on Sundays. Sometimes this causes us to miss things and sometimes people get mad about that or make fun of us. What else can you list?

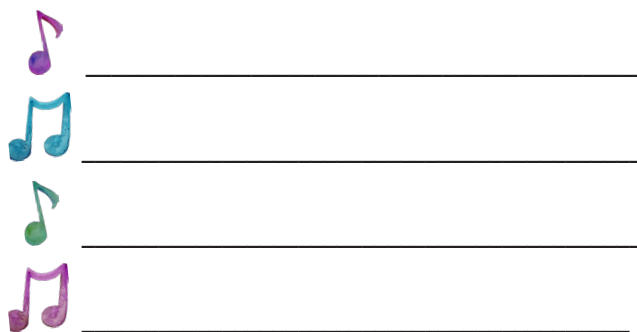
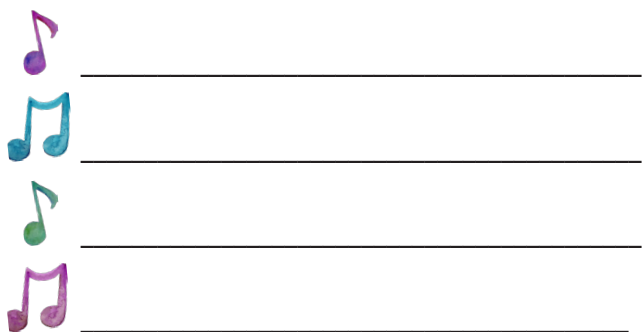

As we close today, take some time and pray and ask God to forgive you for the times you haven't stood up for your beliefs. He doesn't expect you to be perfect. We all fail, but as Christians we want to grow and get better. Write your prayer below.







- Practice holding the tin whistle properly
- Practice making loud and soft sounds
- Play the D scale
- Play the hymn

The *Tempo* tells you how fast or slow the music goes.

Instruction: Fill in the missing letters below.

P  E  T O

(very fast)

L L E   E T  O

(fast, but not as fast as Allegro)

M  D   A  O

(at the moderate speed)

A N    T E

(at the walking pace)

A   G  O

(slow)

A   E   O

(fast and lively)

E S T   S I

(fast and rapid)



# Copywork

I have decided to follow Jesus;  
The world behind me, the cross before me;  
Though none go with me, still I will follow;  
My cross I'll carry, till I see Jesus;  
Will you decide now to follow Jesus?  
No turning back, no turning back.

Handwriting practice lines consisting of multiple sets of solid top and bottom lines with a dashed midline for letter height guidance.



# I HAVE DECIDED TO FOLLOW JESUS

In the picture frames below draw people you know who are Christians. Ask each of them to share their testimony with you. At the bottom, share about one of the testimonies.

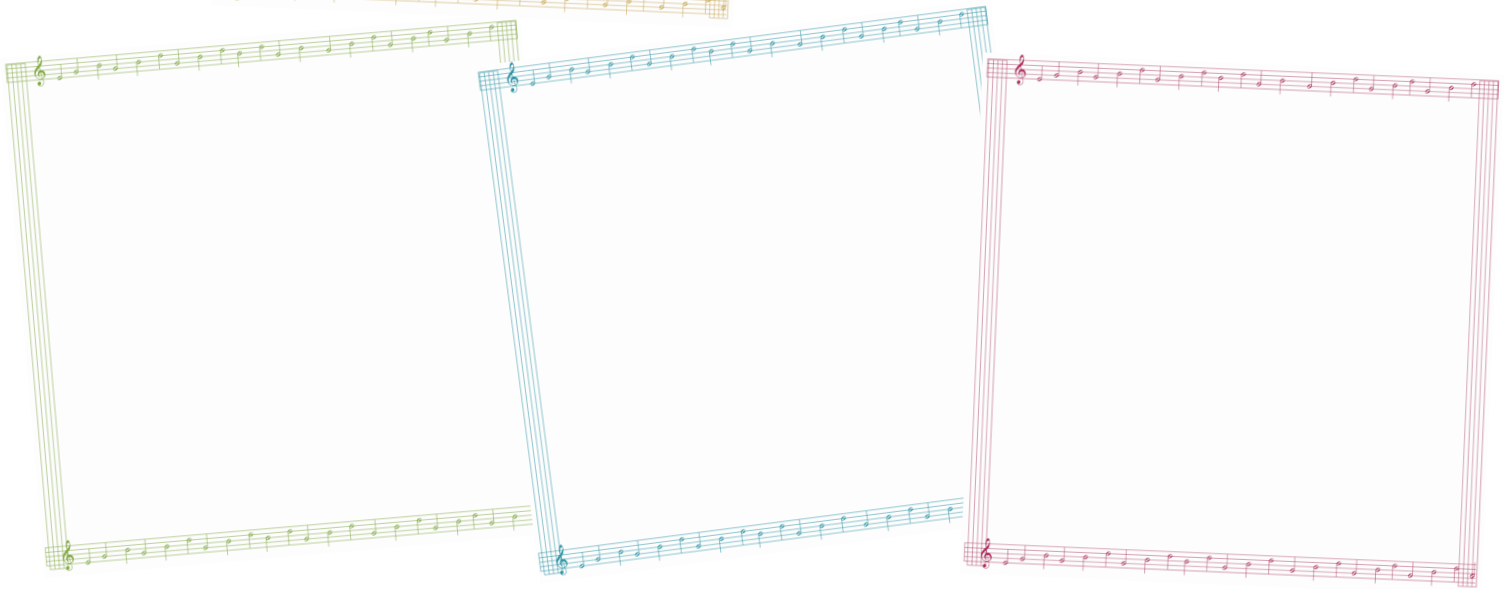
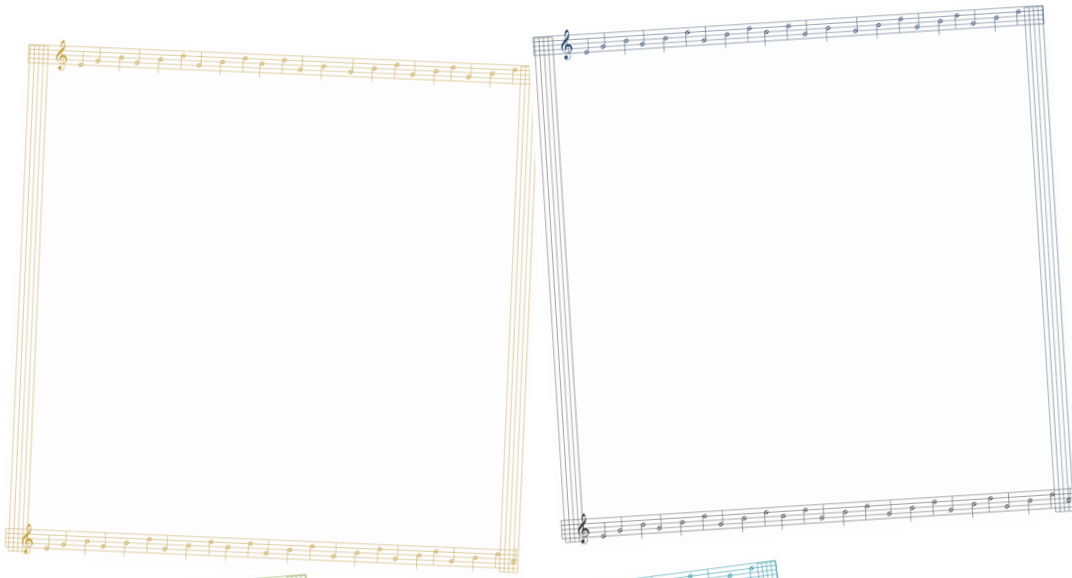

---

---

---

---

---

---

# Extension Activities



Next time you are at the store or other public place, take along 5-10 gospel tracts or hand made notes with Bible verses on them and pass them out.



Think about what it would be like to become a missionary. Draw a picture of a cross and on it write some things you would possibly have to give up to go to the mission field.



Trace your feet on a piece of construction paper. Cut out the feet and write on them all the places you can stand for Jesus.



Find a missionary your church supports who is in a dangerous place. Study that area so you can understand how to better pray for that missionary.



Research Assam India and write a news report about the conditions now or in the 1800s.





# COUNT YOUR BLESSINGS

*the story*

The hymn, "Count Your Blessings," was originally published in a hymnal for young people in 1897 and has been a popular choice for Thanksgiving services for generations. Hymn writer, Johnson Oatman, wanted young people to understand the importance of being thankful for the many blessings God had given them, no matter what their circumstances.

Born in New Jersey just before the Civil War, Johnson was very familiar with music. His father had a beautiful and powerful voice, and Johnson grew up standing beside him in song. Johnson so admired his father, he wanted to grow up to follow in his footsteps, working alongside him in the mercantile business.

His heart's desire to contribute something to his father's strong faith also led him to become a local preacher. The trouble was, he wasn't a very good preacher, and he wasn't a very good missionary either. It seemed as though he had failed miserably until one day in 1892 when he picked up his pen and started writing hymns.

He had finally found his calling and his contribution to the faith. Within three years the world was singing hundreds of his songs. When he wrote "Count Your Blessings" in 1897, it was thought to be his most popular hymn ever, but in 1898 he published "Higher Ground," which to date has been his most beloved hymn of all time.

He lived his life maintaining both jobs equally and still averaged 200 hymns a year. In the course of his lifetime, Johnson Oatman wrote over 5000 hymns and gospel songs. Some of his most famous hymns are "Higher Ground," "All the Way My Savior Leads Me," and "Count Your Blessings," which has been published in 189 hymnals.

Although he thought he was a failure as a pastor, his songs have spread the gospel to reach millions of people, far beyond what he ever could have done in a local church in New Jersey. His life is an inspiration to never give up trusting in God's blessings for your life.



# Hymn Study Notes

NAME OF THE HYMN

---

WRITTEN BY

---

YEAR & LANGUAGE THE HYMN WAS WRITTEN

---

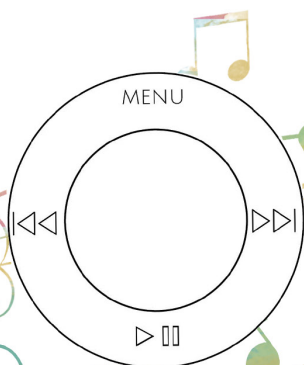

FACTS ABOUT THE AUTHOR



---



---



---



---



---



---

TELL ABOUT THE STORY BEHIND THE HYMN

---

---

---

---

---

---

---



# Bible LESSON

The author of this hymn wanted to encourage people to remember the many blessings that God had given them when they were feeling discouraged.

James 1:17 is a great verse to go with this hymn. Read it in your Bible and then write it below.



---

---

---

Sometimes we are thankful for the gifts God has given us, but other times we don't feel that way. Have you ever been guilty of complaining about the gifts that God has given you? Let's look more closely at the verse James 1:17. Where are the gifts coming from?

---

What kind of gifts does the verse say we are given?

---

What does the last part of this verse say about God?

---











I hope you noticed that the Bible says EVERY gift is both good and perfect and that God never changes. That's a pretty comforting thing to think about when you feel like things in your life aren't fair or when they aren't going according to your plan. The Bible (and this hymn) teaches us that when we are discouraged or worried about the things in our life, we need to be thankful to God.

Think of something hard in your life, perhaps trouble with a friend at school, a friend or relative who is sick, or even the trouble in our country. Make a list of at least five things that you can be thankful for, despite that situation. For example, our friend has cancer, but we are thankful that she has the opportunity to share Christ and witness to the many doctors and patients around her.



1. \_\_\_\_\_
2. \_\_\_\_\_
3. \_\_\_\_\_
4. \_\_\_\_\_
5. \_\_\_\_\_

Now let's count some of your blessings. The hymn tells us to name them one by one so we can see what God has done! Make a list of at least 10 blessings below.





 _____	 _____
 _____	 _____
 _____	 _____
 _____	 _____
 _____	 _____

As we close today, take some time to pray over each thing you listed above. Thank God for them specifically and consider how God is using them in your life for His glory.

























-  Practice holding the tin whistle properly
-  Practice making loud and soft sounds
-  Play the D scale
-  Play the hymn

Draw the correct symbol in each box. Use the "symbol bank" below to help you.

staff		bar line		quarter note		quarter rest	
treble clef		repeat sign		eighth note		eighth rest	
bass clef		whole note		sixteenth note		sixteenth rest	
common time		dotted half note		whole rest		flat	
time signature		half note		half rest		sharp	

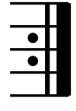
SYMBOL BANK



# Copywork

When upon life's billows you are tempest-tossed,  
When you are discouraged, thinking all is lost,  
Count your many blessings, name them one by one,  
And it will surprise you what the Lord has done.  
Count your blessings, name them one by one,  
Count your blessings, see what God has done!

Handwriting practice lines consisting of solid top and bottom lines with a dashed midline, repeated 10 times.



# COUNT YOUR BLESSINGS

In each of the numbers below, draw or write something you have that many of. For example, for the number one you might write "mom, house, or face" because those are likely all things you have only 1 of.

1

2

3

5

6

10

20

100

# Extension Activities



Start a blessing journal or a blessing tree to hang on your wall. Add new ideas to it often.



Give something that belongs to you to someone who needs it more than you do.



Learn about the poverty in America today. Make a chart showing what you learn.



Learn about poverty in another country today. Make a Venn diagram contrasting that country with America.



Research the life of Johnson Oatman and give a speech to your family on his life.





# PRAISE GOD FROM WHOM ALL BLESSINGS FLOW *the story*

Like many hymns, this one is known by multiple names: "Praise God from Whom All Blessings Flow" and "The Doxology." Webster's dictionary defines doxology as an expression of praise to God and that's exactly what it was written to be!

Its author, Thomas Ken, was known as England's first hymn writer. He was born in 1637 and raised by his sister after the death of his parents. He attended Winchester College, a historic boys' school, where he later became chaplain.

In 1674, Thomas wrote three hymns to encourage the boys to have good devotional habits. At that time, hymns were not allowed to be sung in services. Churches only sang psalms publicly. Thomas encouraged the boys to sing hymns privately in their rooms.

He wrote a morning hymn, a bedtime hymn, and one to be sung in case the boys were still unable to sleep at midnight. The morning hymn had 13 stanzas beginning with:

*Awake, my soul, and with the sun thy daily stage of duty run:  
Shake off dull sloth and joyful rise, to pay thy morning sacrifice.*

The evening hymn was just as powerful in focusing their thoughts on God above before their heads hit the pillow:

*All praise to Thee, my God, for all the blessings of the light!  
Keep me, O Keep me, King of Kings, beneath Thine own almighty wings.*

All three hymns ended with a common stanza, which is "The Doxology" as we know it today. This short and beautiful truth has been the most widely sung verse in the world.

Thomas went on to write 50+ hymns in his lifetime, but none as well known as "The Doxology." This hymn may be the most popular addition to any hymnal, being published in 713 hymnals since 1674.



# Hymn Study Notes

NAME OF THE HYMN

---

WRITTEN BY

---

YEAR & LANGUAGE THE HYMN WAS WRITTEN

---

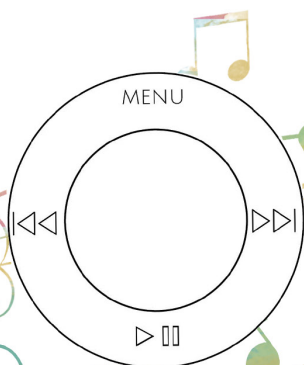

FACTS ABOUT THE AUTHOR



---



---



---



---



---



---

TELL ABOUT THE STORY BEHIND THE HYMN

---

---

---

---

---

---

---



# Bible LESSON

Hymn writers based their hymns on God's Word, but we don't always know which verse they may have used. In this case, one possibility for this hymn is Ephesians 1:3. Look up that verse and write it below. Then draw whatever comes to mind when you sing this hymn.



A large rectangular area with a dashed blue border, intended for writing and drawing. A musical staff with notes is in the top left corner, and a cluster of musical notes is in the bottom right corner.

It is a regular practice in our culture to be thankful; even non-believers understand the power of being positive and grateful. Christians must be very careful that we don't forget the most important part of this thanksgiving—to recognize and give credit to the Creator. All blessings come from God. Not just one or two things, ALL things. We must recognize where our blessings come from, just as much as we acknowledge that we have those blessings!

Remember Ephesians 1:3? Go back to your Bible and read that verse again.

Who has blessed us? \_\_\_\_\_

What kind of blessings has He given us? \_\_\_\_\_







Today let's look at Ephesians 1:3-14. God doesn't leave us guessing about what these spiritual blessings are. He tells us right here in His Word. After reading the passage, make a list of at least five spiritual blessings God has given you. I've done the first one to give you an example.

 **Thank you, God, for choosing me even before the world was made. (v. 4)**

---

 \_\_\_\_\_

 \_\_\_\_\_

 \_\_\_\_\_

 \_\_\_\_\_

Spiritual blessings are something only Christians have and they are absolutely the best part. Take time now to pray and thank God for giving you these things. Journal your thoughts below.

---



---



---













---







---

Finish our lesson today by recording 10 more blessings you have to be thankful for. Don't use any of the things you recorded when you did Count Your Blessings in the last lesson.

 _____	 _____
 _____	 _____
 _____	 _____
 _____	 _____
 _____	 _____







-  Practice holding the tin whistle properly
-  Practice making loud and soft sounds
-  Play the D scale
-  Play the hymn

Fill out each blank with the correct number of beats (in  $\frac{4}{4}$  time)

 = \_\_\_\_\_

 = \_\_\_\_\_

 = \_\_\_\_\_

 = \_\_\_\_\_

 = \_\_\_\_\_

 = \_\_\_\_\_

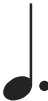
 = \_\_\_\_\_

 = \_\_\_\_\_

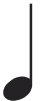
 = \_\_\_\_\_

 = \_\_\_\_\_

 = \_\_\_\_\_



# Copywork

Praise God, from whom all blessings flow;  
Praise Him, all creatures here below;  
Praise Him above, ye heav'nly host;  
Praise Father, Son, and Holy Ghost. Amen.

Handwriting practice lines consisting of solid top and bottom lines with a dashed midline, repeated 10 times.



# PRAISE GOD FROM WHOM ALL BLESSINGS FLOW

Unscramble the words.

1. bsnslgeis \_\_\_\_\_

2. asriep \_\_\_\_\_

3. tgsinnhvkiag \_\_\_\_\_

4. srupticalr \_\_\_\_\_

5. esapehnis \_\_\_\_\_

6. yodxgolo \_\_\_\_\_

7. tnuafkhl \_\_\_\_\_

8. omtahs ekn \_\_\_\_\_

9. mylnha \_\_\_\_\_

10. cueertars \_\_\_\_\_

## WORD BANK

doxology

thankful

blessings

Ephesians

creatures

praise

Thomas Ken

hymnal

thanksgiving

scriptural

# Extension Activities



Learn about the culture in England during the 1600's, specifically regarding Christianity. Create a chart showing what you learn.



Write a short story about an adventure that might have happened in a boys' school like the one Thomas Ken taught at.



Learn about old English words that we no longer use today and write their meanings.



Print out a map of the world and locate England and America. Learn the names of a few surrounding countries or cities.



Go to the library and find books on thankfulness to read.





# GREAT IS THY FAITHFULNESS

*the story*

"Great Is Thy Faithfulness" was first published in 1923 by Thomas Obediah Chisholm. In terms of hymns, it's relatively young, being less than 100 years old. You might even have a grandma or grandpa who was born before this hymn was written! But just because it is a newer hymn doesn't mean it isn't a favorite. In fact, it has been published in 118 hymnals already and daily reminds Christians of God's faithfulness to us.

Thomas Obediah Chisholm was an American hymn writer who wrote many prominent hymns. He was born in a log cabin in Kentucky and began teaching school at age 16. It wasn't until he was 27 years old that he came to know Christ when an evangelist came to his town. Thomas had a hard life, as he struggled greatly with his health even from a young age.



Despite the many trials and health issues he faced, Thomas Obediah Chisholm wrote 1200 poems and hymns in his lifetime. Through all of his ups and downs, he learned that new blessings flow from God every morning. Lamentations 3:22-23 became very dear to him and the inspiration for this hymn. In his later years, he wrote, "My income has not been large at any time due to impaired health in the earlier years which has followed me on until now. Although I must not fail to record here the unfailing faithfulness of a covenant-keeping God and that He has given me many wonderful displays of His providing care, for which I am filled with astonishing gratefulness."

When this hymn was first written, it was not very popular. In fact, very few people knew or sang it until Dr. Will Houghton of the Moody Bible Institute made it the school's unofficial hymn. But even with Dr. Houghton's love for the precious words of "Great Is Thy Faithfulness," the hymn remained largely unknown until Billy Graham began using it as a part of his crusades teaching people about God.

# Hymn Study Notes

NAME OF THE HYMN

---

WRITTEN BY

---

YEAR & LANGUAGE THE HYMN WAS WRITTEN

---

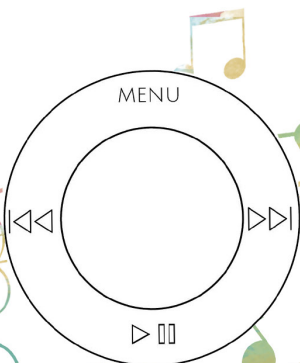

FACTS ABOUT THE AUTHOR



---



---



---



---



---



---

TELL ABOUT THE STORY BEHIND THE HYMN

---

---

---

---

---

---

---



# Bible LESSON

Our hymn this week was inspired by Lamentations 3:22-23. Let's write it here.

---

---

A very famous theologian named Martin Luther (we learned about him a few weeks ago) once wrote, "The greater God's gifts and works, the less they are regarded." Think about that for a minute. What do you think that means?

---

---

I think of it like this. If the sun came up only once a year, we would take note and offer great praise. But since it comes up every morning, we typically go about our day enjoying the gift of light without praising the giver. Have you ever thought about how spectacular God's creation is? Have you ever considered that many of the things you don't even think about are amazing blessings from our loving Father? Take a minute and fill this box with as many everyday blessings as you can think of. You can draw them or just write the names.



God's faithfulness  
is unending,  
and His mercies  
are new every  
morning.

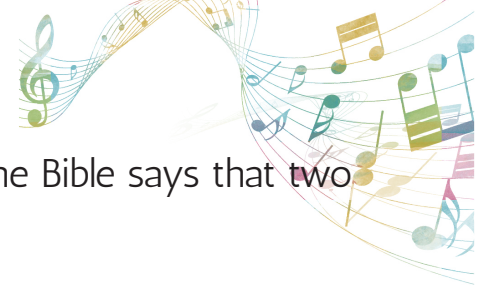

Let's take a closer look at Lamentations 3:22-23. In verse 22, the Bible says that two things never come to an end. What are those two things?

\_\_\_\_\_ and \_\_\_\_\_

Since they don't end, verse 23 tells us what happens to them. Write that whole phrase again below.

\_\_\_\_\_ EVERY \_\_\_\_\_

I think the ending of the verse is rather appropriate, considering our hymn: Great Is Thy Faithfulness!

Get out a thesaurus and look up faithful. Write several synonyms for the word faithful below.











 \_\_\_\_\_

 \_\_\_\_\_

 \_\_\_\_\_

 \_\_\_\_\_

Our God is incredibly faithful. He never changes, never fails, and always has love and mercy for us! Make a list below of 10 things you are thankful that God is faithful to do. (Hint: We've already listed two of them in this lesson!) Don't use any of the things you listed in the last two lessons.

 _____	 _____
 _____	 _____
 _____	 _____
 _____	 _____
 _____	 _____





# Music THEORY

- Practice holding the tin whistle properly
- Practice making loud and soft sounds
- Play the D scale
- Play the hymn

- 1. TEMPO                      A. space between lines indicating notes to be played
- 2. SHARP                     B. is any set of musical notes ordered by pitch
- 3. MEASURE                C. tells you how fast or slow the music goes
- 4. DYNAMICS                D. means to go up a half step
- 5. SCALE                     E. tell you how loud or soft to play the music

Write the D scale on the blank staff.



Fill in the parts of the tin whistle.

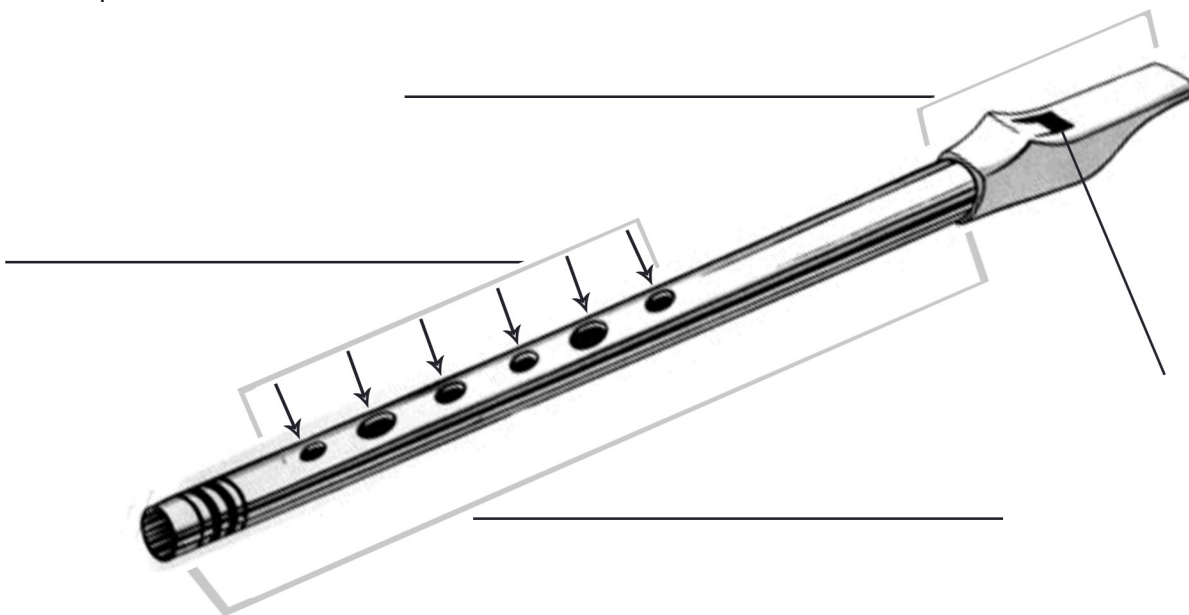



# Copywork

Great is Thy faithfulness, O God my Father;  
There is no shadow of turning with Thee;  
Thou changest not, Thy compassions, they fail not;  
As Thou hast been, Thou forever will be.  
Great is Thy faithfulness!  
Great is Thy faithfulness!  
Morning by morning new mercies I see;  
All I have needed Thy hand hath provided.  
Great is Thy faithfulness, Lord, unto me!

Handwriting practice lines consisting of solid top and bottom lines with a dashed midline, repeated 10 times.

# CHANGES

God never changes, but there are plenty of things that do change. In each of the boxes below draw something that has changed since you were born.

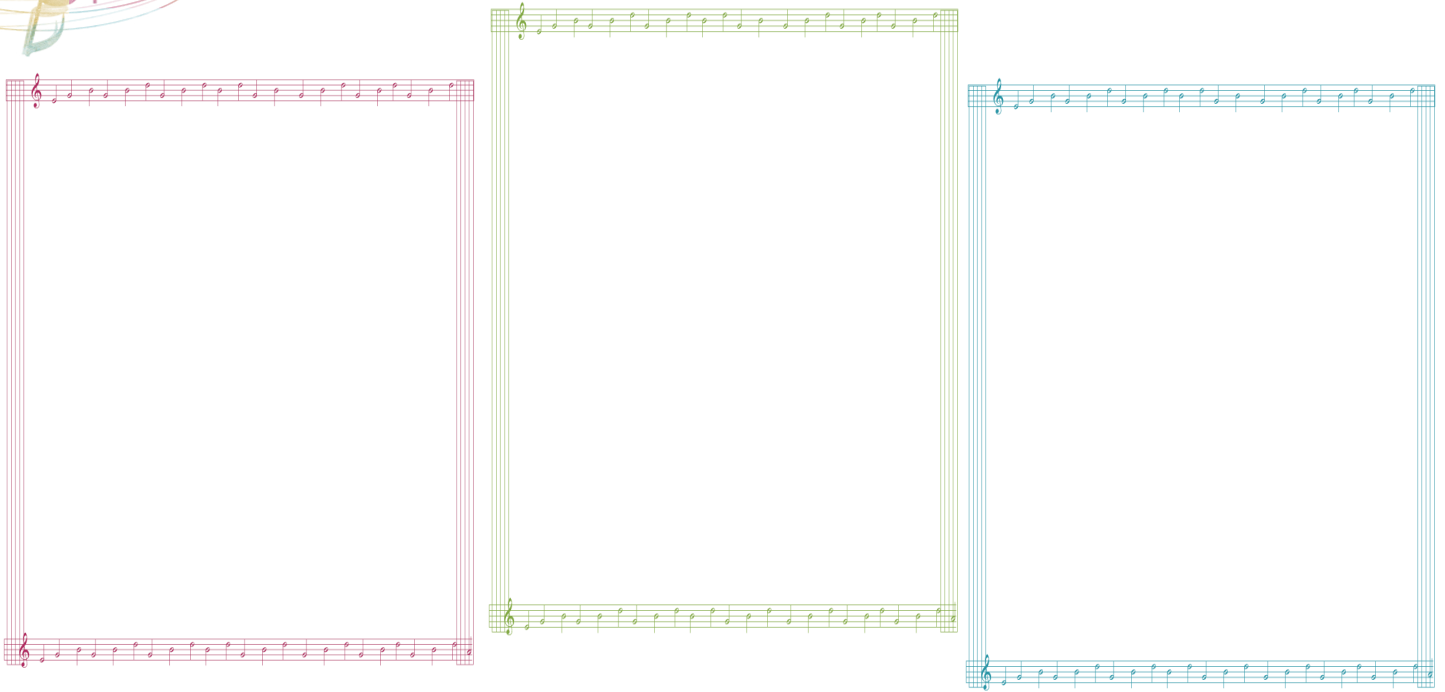

## INTERVIEW

Interview a grandparent or older person and ask them about the changes they have seen.

**Q:** What is your name?

**A:** \_\_\_\_\_

**Q:** What year were you born?

**A:** \_\_\_\_\_

**Q:** How old are you?

**A:** \_\_\_\_\_

**Q:** How much was candy when you were a kid?

**A:** \_\_\_\_\_

**Q:** Name some things that didn't even exist when you were a kid.

**A:** \_\_\_\_\_

**Q:** What are some changes you've seen since you were a kid?

**A:** \_\_\_\_\_

# Extension Activities



Research the work of Billy Graham and record a video of yourself doing a news story on his life.



Learn more about a one room schoolhouse so often used in rural Kentucky. Create a Venn Diagram comparing your homeschool to the one room schoolhouse.



Make a list of 5 things you can do for people in your neighborhood. Try to accomplish each one.



Draw or write at least 10 things you can thank God for that CAN'T be purchased with money.



Using the acronym FAITHFULNESS write one thing you are thankful for after each letter.





# O COME, O COME, EMMANUEL

*the story*

"O Come, O Come, Emmanuel" is probably the oldest Christmas hymn. Its lyrics come from the Advent events of the medieval Christian church. Each night, for seven nights before Christmas, the church would sing one of the "Great O Antiphons"—anthems sung to a short verse.

The word *antiphon* implies that the lines of each anthem were sung alternately by two choirs sitting opposite each other. Each antiphon featured a prayer beginning with "O Come" and included an Old Testament reference for the Messiah.

During the twelfth century (1100-1200 AD), five antiphons were put together as verses of a single hymn and a chorus was added, creating the words for "O Come, O Come, Emmanuel." However, the first written evidence of this hymn didn't come until 1710 in Germany. At that time it was written in Latin which makes the title "Veni, Veni, Emmanuel."



76 ADVENT.

**XLVIII.** Veni, veni, Emmanuel!

Melody from a French Missal.  
Harmonized by H. R. SCHAEFER.

O come, O come, Em man - u - el, And ran - som cap - tive  
 If - ra - el; That mourns in lone - ly ex - - ile here, Un -  
 til the Son of God . . . ap - pear. Re - joice! Re - joice! Em -  
 man - - u - el Shall come to thee, O li - ra - - el!

*Hype-Dorian.*

In 1851, John Mason Neale translated this hymn from Latin to English, originally beginning "Draw nigh, draw nigh, Emmanuel." A year later, he changed the opening lines to "O Come, O Come, Emmanuel," the well-known words we use today.

This hymn is a beautiful reminder of the longing of the world at the time when Jesus was born. The culture was very dark and they were desperately seeking the Messiah. In some ways, that's not much different from our culture today.

# Hymn Study Notes

NAME OF THE HYMN

---

WRITTEN BY

---

YEAR & LANGUAGE THE HYMN WAS WRITTEN

---

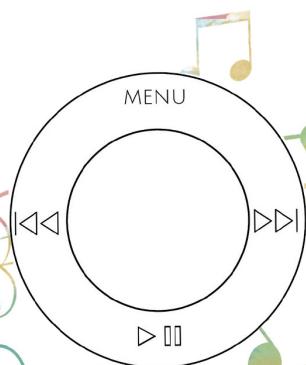

FACTS ABOUT THE AUTHOR



---



---



---



---



---



---

TELL ABOUT THE STORY BEHIND THE HYMN

---

---

---

---

---

---

---



# Bible LESSON

From the time of Moses until today, the one major problem with God's people remains the same. What do we keep doing wrong? What can you do in your life to avoid this major sin? Read Judges 10:10 and 2 Chronicles 7:14.

---

400 years passed between the final words of the prophets of the Old Testament and the birth of Jesus. The people were living in very dark times. They had spent much time in captivity and bondage. They had failed to trust God, and they worshiped idols over and over again despite the punishments and warnings. Sin had taken over the earth, and the people were hopeless.

Have you ever felt like it was impossible to stop sinning or making wrong choices?

---

---

The hymn "O Come, O Come, Emmanuel" is a cry of the people for help, hope, and salvation. We mentioned it was divided into five parts that tell about the coming of Jesus. Read the verses below and match them with the theme from the hymn listed on the right.

Isaiah 22:22



The Mighty Lord (Adonai)

Isaiah 11:1



Emmanuel (God with us)

Exodus 20:1 - 2, 18

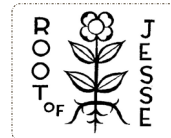

Rod or branch of Jesse

Isaiah 7:14



Star of Jacob (Dayspring)

Numbers 24:17



Key of the house of David





If all the details of those verses didn't make sense to you, don't worry. Theologians have studied the prophecies of Jesus for hundreds of years, and you're likely just beginning to look at these things. But don't give up. As you grow in Christ, this is important stuff to learn!

It's important because the promise of Christ is the most beautiful blessing we have as Christians. Let's look at one of my favorite prophecies or verses that tell about the coming of Christ.

Read Isaiah 9:6. Record the names of our Savior below.

 \_\_\_\_\_

 \_\_\_\_\_

 \_\_\_\_\_

 \_\_\_\_\_

Over the course of our lives, we need all four of those attributes of Jesus, but usually there is one that is most meaningful to us in the moment. When you read those names, which one means the most to you today and why?

\_\_\_\_\_

\_\_\_\_\_

\_\_\_\_\_

\_\_\_\_\_

\_\_\_\_\_



End your study today by praying and thanking God for sending His Son to be our Savior. Try to tell Him specifically why that is so important to you.





- Practice holding the tin whistle properly
- Practice making loud and soft sounds
- Play the D scale
- Play the hymn

*Strings* may be plucked, as in a guitar or harp; bowed, as with a cello or a violin; or struck, to create a musical sound.

*Percussion* make sounds when they are hit.

*Woodwind* produce sound when air (wind) is blown inside.

*Brass* are made of brass or some other metal and make sound when air is blown inside.

INSTRUCTIONS: Label each instrument group with their correct family name.

<p>_____</p>	<p>_____</p>
<p>_____</p>	<p>_____</p>



# Copywork

O come, O come, Emmanuel,  
And ransom captive Israel  
That mourns in lonely exile here  
Until the Son of God appears.  
Rejoice! Rejoice! Emmanuel shall come to thee, O Israel.

Handwriting practice lines consisting of solid top and bottom lines with a dashed midline, repeated 10 times.

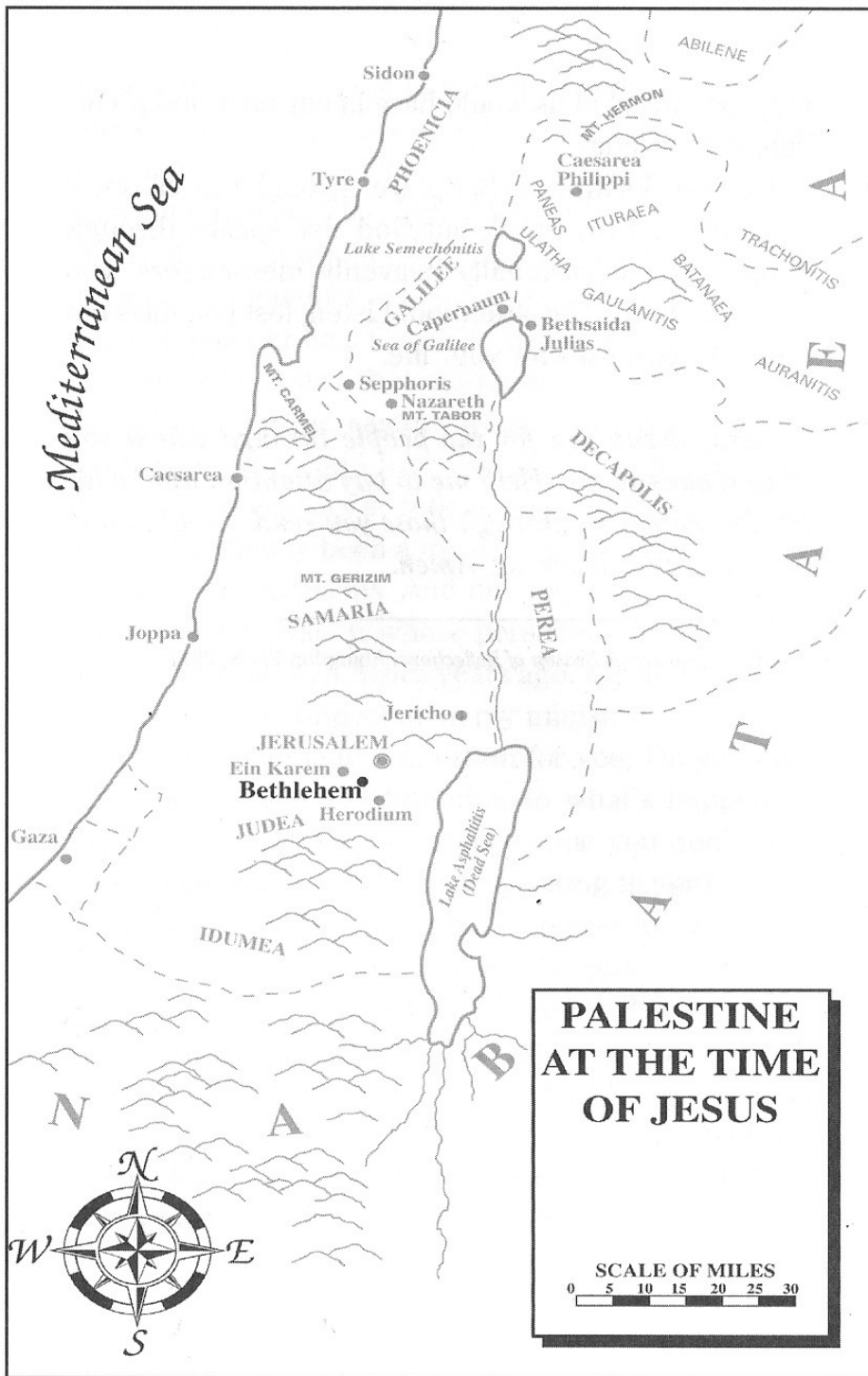

Find the town that Mary and Joseph were from. Read Luke 2:1 - 4.

Trace their journey on your map.

The journey was 80 miles, which probably took them about a week to walk!

What do you think the journey might have been like for Mary and Joseph?

---



---



---



---

# Extension Activities



With the help of your parents, listen to versions of this hymn sung in other languages (YouTube has several).



Starting in Genesis draw the major events of the Bible from Creation until Christ was born. Cut your drawings out and glue them in order like a timeline.



Write a story about an Israelite boy or girl who was waiting for the Messiah.



Isaiah 9:6 lists several names for Jesus. Research others and draw them on a poster to display in your room. Older kids can include the references where those names are listed.



Record a new report (video) of how the hymn was written. Share it with your family.





# SILENT NIGHT

## *the story*

This beloved hymn has roots back to the year 1818. In the small Austrian village of Oberndorf, the church's organ wasn't working and would not be repaired before Christmas. (Note: some versions of the story point to mice as the problem; others say rust was the culprit.) Because the church organ was out of commission, actors presented their Christmas drama in a private home.

That Christmas presentation of the events in the first chapters of Luke put assistant pastor Josef Mohr in a thoughtful mood. Instead of walking straight to his house that night, Josef took the long way home up a hill overlooking the village.

From that hilltop, Josef looked down on the peaceful snow-covered village. Reveling in the majestic silence of the wintry night, he gazed down at creation and remembered a poem he had written a couple of years before. That poem was about the night when angels announced the birth of the long-awaited Messiah to shepherds on a hillside.

So the next day, Josef went to see the church organist, Franz Xaver Gruber. Franz only had a few hours to come up with a melody which could be sung with a guitar. However, by that evening he had managed to compose a musical setting for the poem. It no longer mattered to Josef and Franz that their church organ was inoperable. They now had a Christmas carol that could be sung without that organ.

In 1863, nearly fifty years after first being sung in its original language of German, "Silent Night" was translated into English by John Young. Eight years later, that English version made its way into print in Charles Hutchins' *Sunday School Hymnal*. Today the words of "Silent Night" are sung in more than 300 different languages around the world.

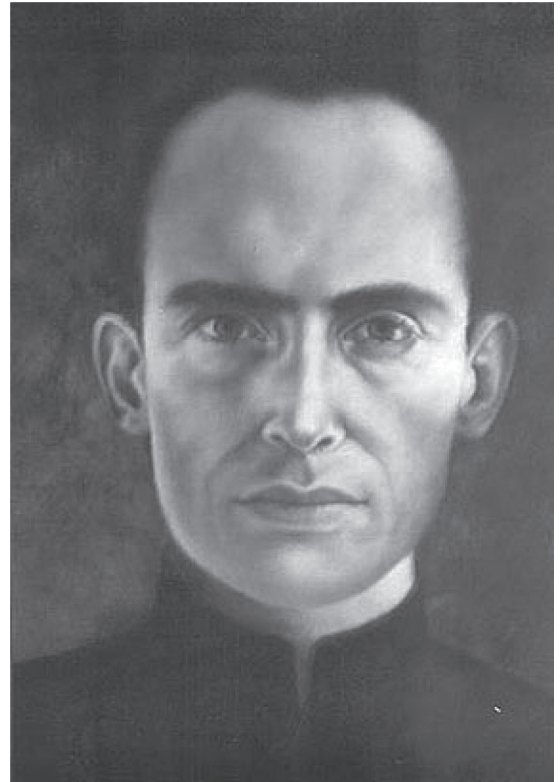

# Hymn Study Notes

NAME OF THE HYMN

---

WRITTEN BY

---

YEAR & LANGUAGE THE HYMN WAS WRITTEN

---

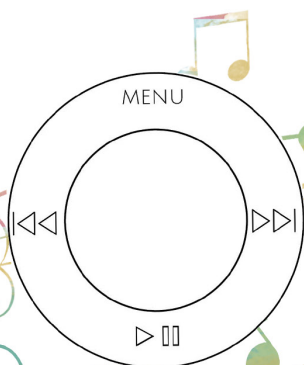

FACTS ABOUT THE AUTHOR



---



---



---



---



---



---

TELL ABOUT THE STORY BEHIND THE HYMN

---

---

---

---

---

---

---



# Bible LESSON

"All was silent" according to the writer of this hymn. Can you imagine how you might have felt after waiting so long for a Savior? What do you think you would do and say if you had met Him that night in the manger?

---

---

---

---

---

---

---

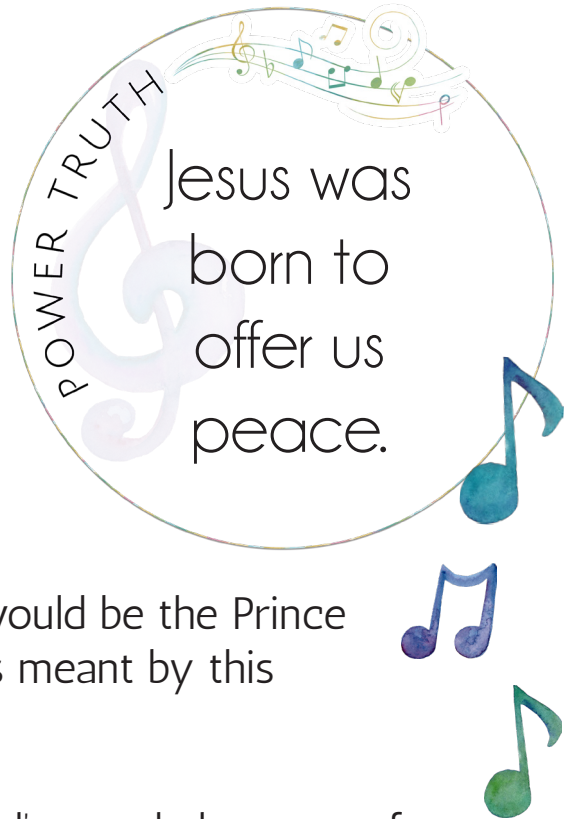

Although we often imagine that night as a silent one, the Bible doesn't say baby Jesus didn't cry. But Isaiah 9:6 does say that Jesus would be the Prince of Peace. Let's look in the Bible and see what is meant by this peace.

Read Isaiah 32:17 - 18. What will we gain as God's people because of the peace that He gives us?

---

---

---

How can we have peace? Write Isaiah 26:3 here.

---

---

---



This is one of my favorite verses because it reminds me that no matter how crazy or hard life gets, there is actually only one secret to peace. Go back and circle that secret from the verse you just wrote.

What do you think it means to have our minds "stayed" on Jesus? What might we need to do to accomplish this?

---

---

I know for me, if I'm going to focus my mind on Jesus, I need to spend time praying and reading His Word. I also need to block out the other things in this world that distract me. Are there any distractions you need to block out today?

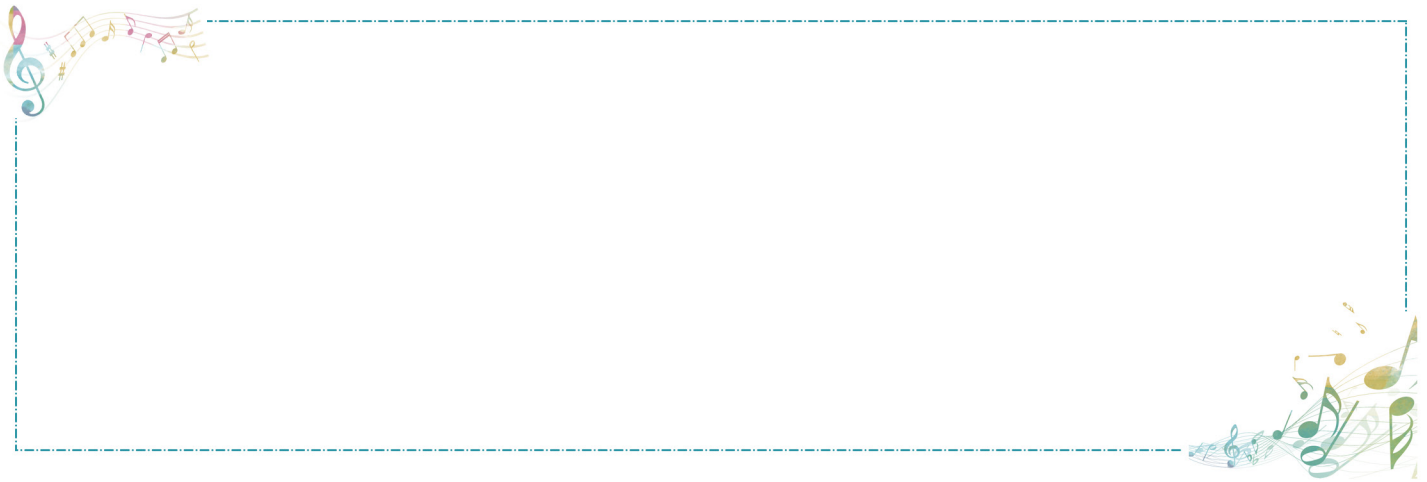

Sometimes people confuse peace with the promise of a trouble-free life. The Bible promises peace, but it doesn't say we won't have trouble. Read John 16:33. Why do we have hope in times of trouble?

---

---

End your Bible time today by praying and asking God to help you stay focused on Him. Thank Him for the promise of peace that was born in His son Jesus!





- 🎵 Practice holding the tin whistle properly
- 🎵 Practice making loud and soft sounds
- 🎵 Play the D scale
- 🎵 Play the hymn

Label the woodwind instruments.

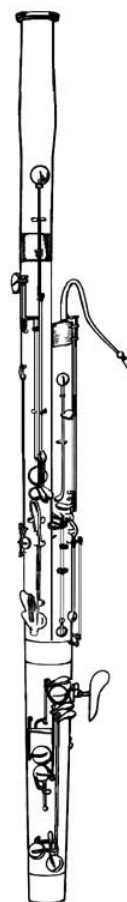
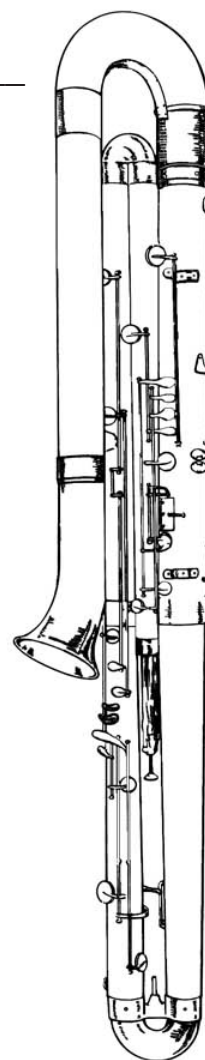
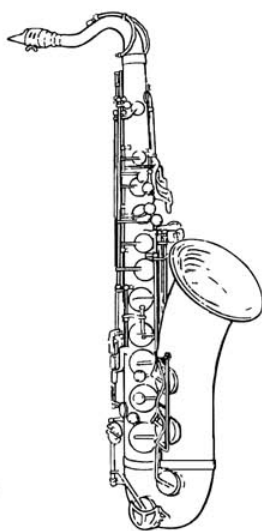



# Copywork

Silent night! Holy night!

All is calm, all is bright

Round yon virgin, mother and child;

Holy infant, so tender and mild,

Sleep in heavenly peace,

Sleep in heavenly peace.

Handwriting practice lines consisting of solid top and bottom lines with a dashed midline, repeated 10 times.



# SILENT NIGHT

*word search*

H U V J L X B T L C A P Q Z N P E A C E  
X G S Q V O Y B A A Z A H K W O D Z W Z  
J V Z R B F L N A L Z F C O X W A X J P  
Z Y M N L N P Z R M S X G O L V M F R C  
O D Z D X S K N G M E T Y O O Y K E K P  
B W U M W G H S T K C Q B B A Q B S P G  
E O L N O X H L S C S M Y U D N D X J L  
V S B U B T Q B Z U Q Y K Q V I F H J G  
C I I U D L H S S Q E R I P G G Z X P C  
Y L R E W U H E X B D Q J I B H D B I A  
Y E T G I L J C R G C B B S S T R R R Q  
X N H G I Q D K P J N F R N X E S I Z C  
T T Y E I N U E W C H I L D G I X G L O  
E M J I B Q D K L V N D K N B M A H W G  
Q S I F K K V L X O L J A U A X G T I V  
I F U U E J Z D G A O M N A O O B F Y R  
G Y S F O T L O W S R M D X V T X I C S  
O B U J R F R R H K D I Z I I N E Z X R  
N M F L W N N D C C R N P H L Y V V J G  
O S F Z I I N F A N T K H E A V E N L Y

CALM  
SILENT  
HOLY  
CHILD  
JESUS

BRIGHT  
NIGHT  
PEACE  
INFANT  
LORD

MANGER  
VIRGIN  
MOTHER  
HEAVENLY  
BIRTH

# Extension Activities



Learn about Bethlehem today and present the information to your family in a fun way.



Write a story from the point of view of Mary, Joseph, a shepherd or the innkeeper during the time of Jesus' birth. Tell what the experience was like.



Re-enact a Christmas story presentation with siblings or friends.



Create something beautiful or bake something yummy and give it to someone you know. Include a card with a picture of the first Christmas and a Bible verse.



Watch The First Christmas Town by Answers in Genesis.





# GOD REST YE MERRY, GENTLEMEN

*the story*

"God Rest Ye Merry, Gentlemen" is perhaps the most famous and most loved of all the early carols. Written with an upbeat melody and speaking of the birth of Jesus in joyful terms, the song shocked early church leaders, but it charmed their flocks. Not only did they sing to this carol, they danced to it and cherished its hopeful message.

The hope and joy of this hymn were quite different from the songs regularly sung during worship, making its history difficult to track. The writer likely was afraid to publish his name, and church leaders would not have published something like this either.

It was probably sung for hundreds of years before its first recorded version found in *Three New Christmas Carols*, dated c. 1760. The writer probably didn't publish his name on the hymn because, again, at the time, church leaders did not accept upbeat and lively hymns such as this one.

By the mid-1800s, Queen Victoria delighted in carols and revived the hymn in the Anglican church, creating a popularity that swept across the country and even into the United States. The carol would have been sung by the waits of olden England. Waits were city employees whose duties included singing carols and songs at city events. Even Charles Dickens quoted the hymn in his famous story, *A Christmas Carol*.

The words really don't make sense to us today, but in that time they had significant meaning. "God Rest Ye Merry, Gentlemen" can more accurately be said: "God Make You Mighty, Gentlemen." I love thinking about that. Yes, God sent His Son into this world to make us mighty. Mighty to serve Him and resist the enemy! Mighty to love others and conquer sins and fears. I think you would agree with the lyrics of this tune. It's the birth of Christ that gives us great TIDINGS OF COMFORT AND JOY!

God Rest Ye Merry Gentlemen

WITH SPIRIT

1. God rest ye mer-ry gentlemen Let noth-ing you dis-may, Re-  
2. From God that is our Fa-ther, The bless-ed An-gels came, Un-  
3. God bless the rul-er of this House, And send Him long to reign, And

mem-ber Christ our Sa-viour Was born on Christ-mas day, To save poor souls from  
to some cer-tain Shep-herds, With tid-ings of the same; That there was born in  
many a mer-ry Christ-mas May live to see a-gain. Among your friends and

CHORUS

Sa-tan's power Which had long time gone a-stray, And God send you  
Beth-le-hem, The Son of God by name,  
kin-dred, That live both far and near.

hap-py new year, hap-py new year; And God send you a hap-py new year.

*The words and music of this lighthearted air are the work of some sixteenth-century English composer whose identity is no longer known.*

# Hymn Study Notes

NAME OF THE HYMN

---

WRITTEN BY

---

YEAR & LANGUAGE THE HYMN WAS WRITTEN

---

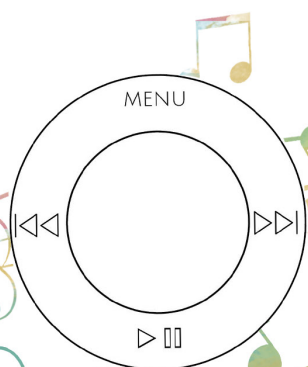

FACTS ABOUT THE AUTHOR



---



---



---



---



---



---

TELL ABOUT THE STORY BEHIND THE HYMN

---

---

---

---

---

---

---



# Bible LESSON

As we learned, the lyrics in this hymn actually mean "God make you mighty, gentlemen." Did you know that you have mighty power? Let's look in the Bible and see what that means.

Write 2 Timothy 1:7 here:

---

---

Circle the word power in that verse. Now notice what God says He didn't give us. What is it?

---

There are two other things mentioned with power, what are they?

\_\_\_\_\_ and \_\_\_\_\_

It's important to see that God doesn't want us to be afraid, but it's also important to see that the power He gives us comes along with love and self-control. Sometimes when people have power, they use it incorrectly, hurting those around them. But God puts love, self-control, and power all in one awesome package.

Let's read 2 Corinthians 12:9. This verse shares two very important truths about the power we have in Christ. First, how is God's power made perfect?

Through my \_\_\_\_\_

Have you ever considered that? Can you imagine God using the things you are weak in to show His power? It seems backward, but it's exactly how He planned it. If we are strong on our own, others will never see the strength, power, and glory of Christ. We have to be weak so His work in our lives is clear.

What is something you are weak in that God can use to show His power?

---



Look back at 2 Corinthians 12:9 again for the second truth.

The last part of the verse says that Christ's power \_\_\_\_\_ upon me.

I love that word. What a wonderful promise. It's not our power. It's given even in our weaknesses, and it rests upon our lives.

According to Ephesians 3:20, God's power is \_\_\_\_\_

It's so exciting to think that God's power rests on us and is at work within us! With God, nothing is impossible. He will give us everything we need to do whatever He has called us to do.

Write Philippians 4:13 here:

\_\_\_\_\_
\_\_\_\_\_
\_\_\_\_\_
\_\_\_\_\_
\_\_\_\_\_
\_\_\_\_\_

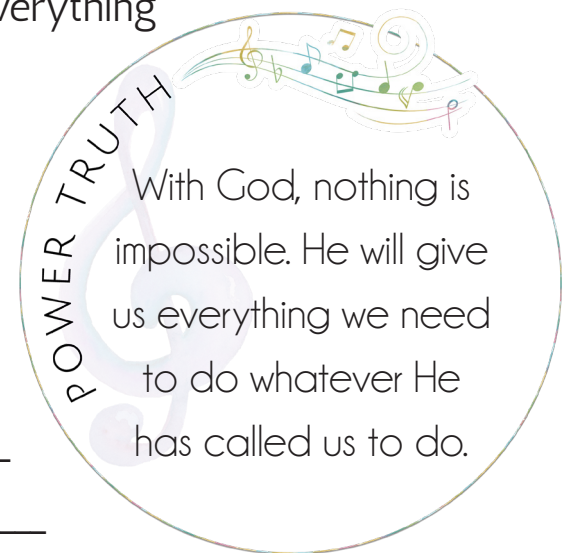

In Christ, God has given me \_\_\_\_\_ to love, obey, and resist the temptation to sin!

Write about what this means to you. Journal a prayer of thanks to God for giving you this power.

\_\_\_\_\_
\_\_\_\_\_
\_\_\_\_\_
\_\_\_\_\_
\_\_\_\_\_





# Music THEORY

Label the string instruments.

- Practice holding the tin whistle properly
- Practice making loud and soft sounds
- Play the D scale
- Play the hymn

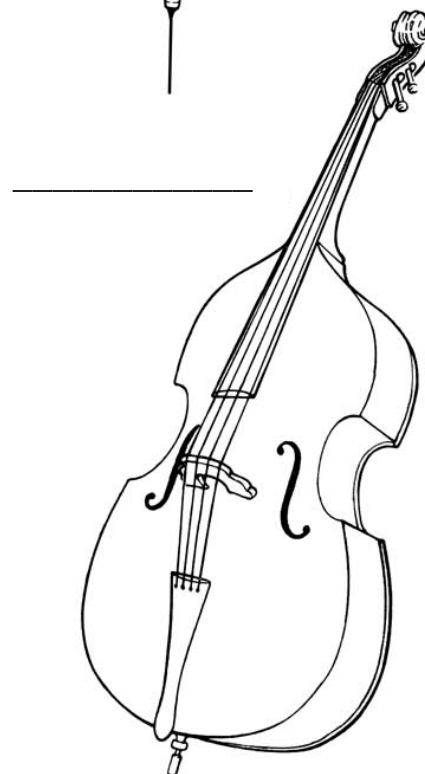
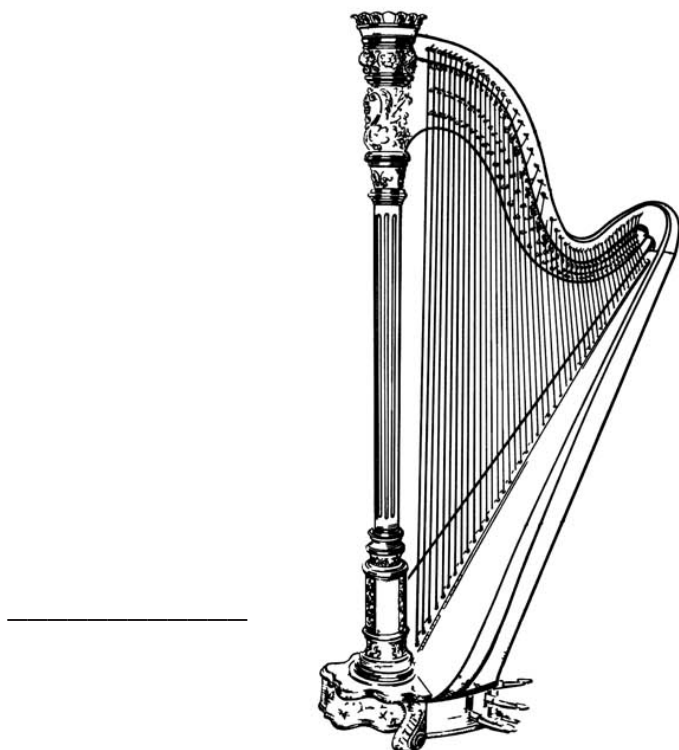
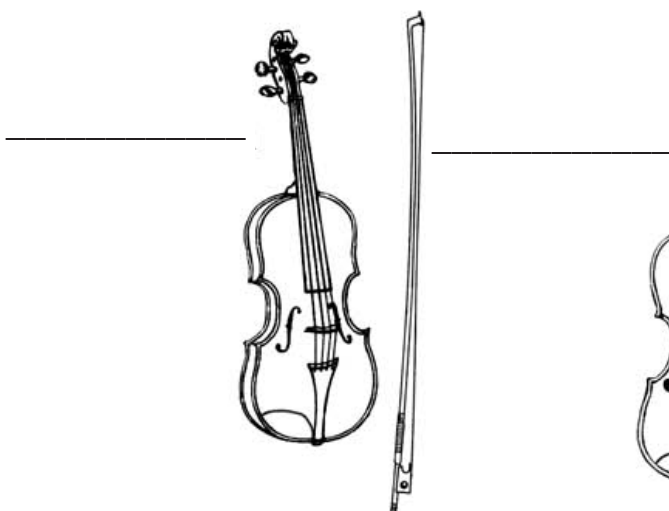



# Copywork

God rest ye merry, gentlemen  
Let nothing you dismay,  
Remember, Christ, our Savior  
Was born on Christmas day;  
To save us all from Satan's power  
When we were gone astray.  
O tidings of comfort and joy, Comfort and joy;  
O tidings of comfort and joy.

Handwriting practice lines consisting of solid top and bottom lines with a dashed midline, repeated 10 times.



# Word Scramble

Use the letters in the title of this hymn to write as many new words as you can think of by scrambling the letters around.

## GOD REST YE MERRY, GENTLEMEN

# Extension Activities



Research Queen Victoria and record 10 interesting facts about her life.



Make a list of popular Christmas carols and go with your family to a nursing home to sing for the residents.



Write John 8:12 on cards and give them out to people you meet.



Illustrate each of the verses of this hymn and use the pages to create a minibook.



Use the 10 interesting facts about Queen Victoria's life to create a story about her.





# JOY TO THE WORLD

## *the story*

Perhaps one of the most popular Christmas carols today, "Joy to the World" is actually the collaborative work of three incredible men of God: Isaac Watts, George Frederick Handel, and Lowell Mason.

The lyrics of the hymn were written by Isaac Watts (1674 - 1748), author of around 750 hymns. He was called "The Father of English Hymnody" not only because he wrote so many, but because he completely changed the way the church sang the psalms when he published his book *Hymns and Spiritual Songs*. A few of his most well-known songs still sung today include: "Come Ye that Love the Lord," "When I Survey the Wondrous Cross," "At the Cross," and of course, "Joy to the World."

"Joy to the World" was written in 1719 and was based on the last half of Psalm 98:4-9. If you notice the lyrics of the song, you will see nothing about shepherds, a manger, wise men, angels, or any other character or element that we normally associate with the Christmas story. Why? Isaac Watts did not write "Joy to the World" to be a Christmas song. The original theme of this song was the second coming of the Lord.

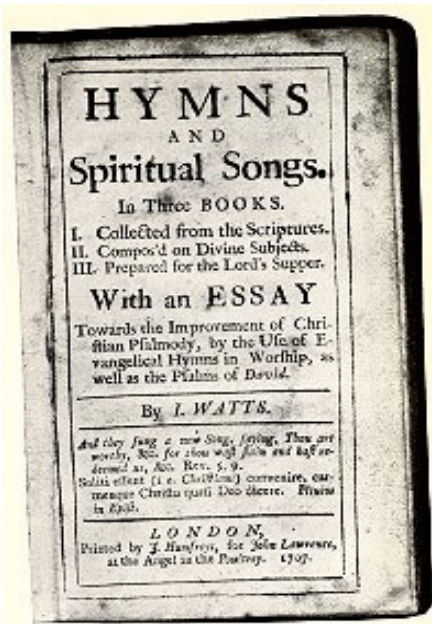
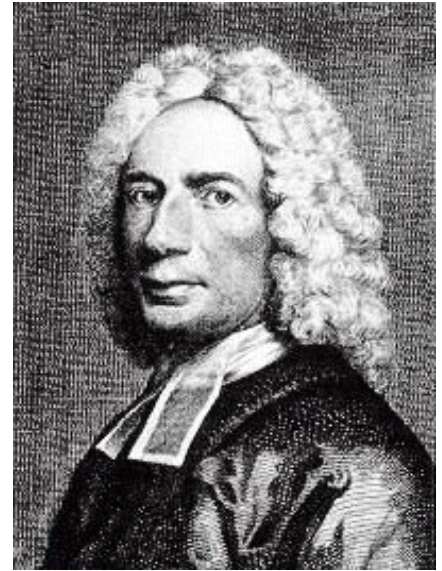

Although they lived at the same time and actually knew each other, the composer of the music, George Frederick Handel, didn't exactly give permission for it to be used. It was common in that day for tunes to be used in many different songs as they were truly acknowledged for their beauty. George Handel created hundreds of pieces, including his most famous, *Messiah*, which included the "Hallelujah Chorus."

Over 100 years later, in 1839, Lowell Mason took the poem of Isaac Watts and the music of George Frederick Handel and arranged this song into the melody we all know and love today. It was at this time that "Joy to the World" became known as a Christmas song.

# Hymn Study Notes

NAME OF THE HYMN

---

WRITTEN BY

---

YEAR & LANGUAGE THE HYMN WAS WRITTEN

---

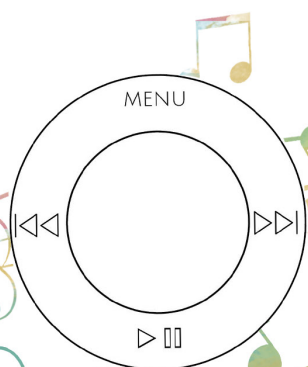

FACTS ABOUT THE AUTHOR



---



---



---



---



---



---

TELL ABOUT THE STORY BEHIND THE HYMN

---

---

---

---

---

---

---



# Bible LESSON

The lyrics to "Joy to the World" were based on Psalm 98:4-9. Let's read that passage now. Draw your thoughts from these verses in the box below.



Isaac Watts was encouraging us, as does the psalmist, to make a joyful noise to the Lord. What are some reasons we have to praise Him? Think back to what we've learned so far from the other hymns or what you've learned in other places. Try to use Scripture to support your reasons at least a few times.



---



---



---



---



---



---

I can't think of anything that brings us more joy as Christians than the birth of Christ. It's no wonder this hymn became popular at Christmas. Let's read Luke 2:1-20 and record below the times where you see joy. Be sure to note the verse number next to the person who is joyous.



---

---

---

---

What about the Christmas story brings you great joy? Journal about that below.

---

---

---

---

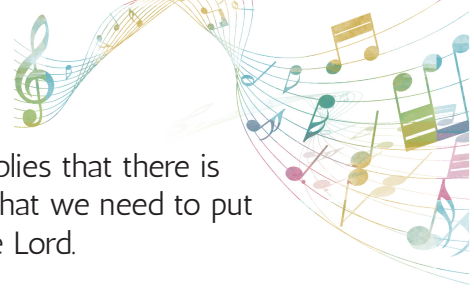

The lyrics in "Joy to the World" say, "Let every heart prepare Him room." This implies that there is something we need to do to make room for Jesus in our lives. James 1:21 says that we need to put off all filthiness and rampant wickedness so that we can receive the Word of the Lord.

In the cross below, list some things that you need to "put off" or stop doing. With Jesus, you can stop doing these things so that you can focus on Him.

In the heart, write the word JESUS.

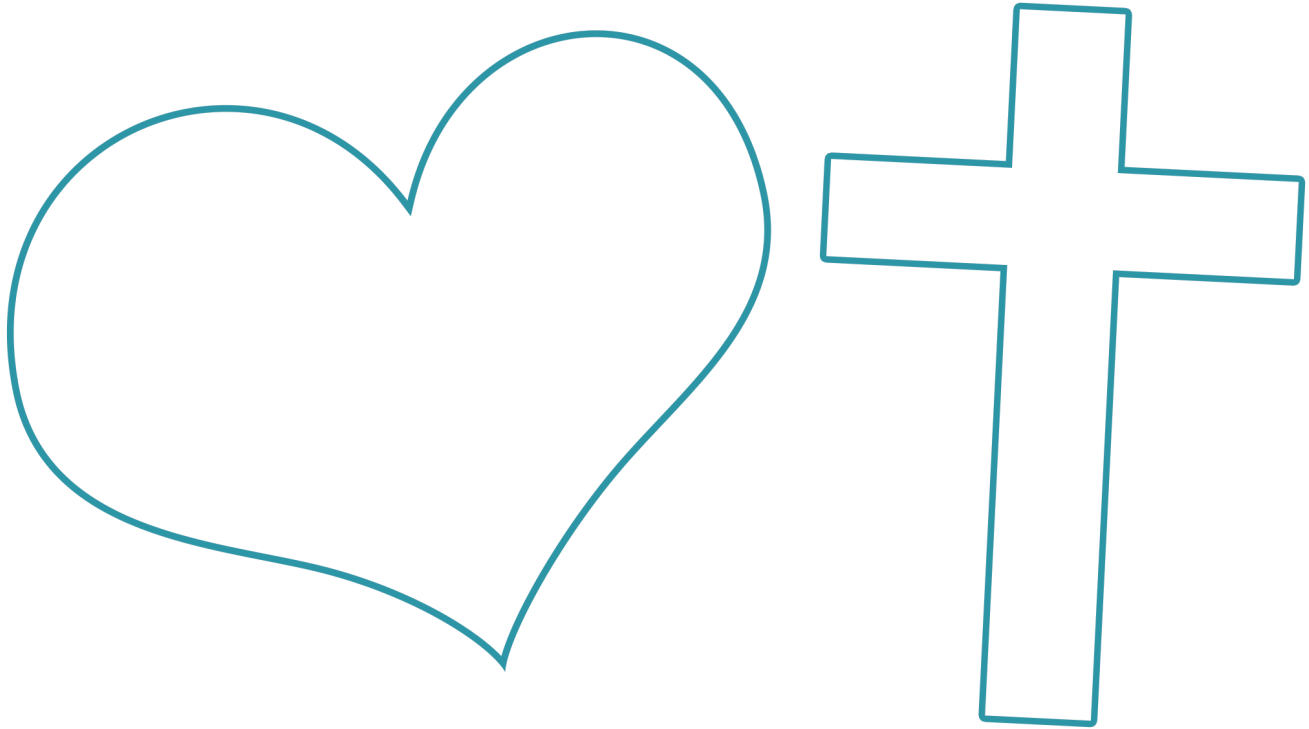

Finish today by writing a prayer to God, asking Him to help you prepare room in your heart for Him. Write your commitment to Him and thank Him for the power to walk away from sins in your life.

Horizontal lines for writing a prayer.







# Music THEORY

Label the brass instruments.

- Practice holding the tin whistle properly
- Practice making loud and soft sounds
- Play the D scale
- Play the hymn

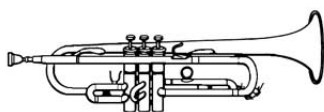

\_\_\_\_\_

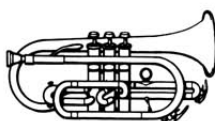

\_\_\_\_\_

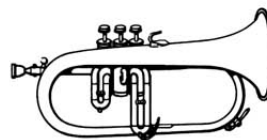

\_\_\_\_\_

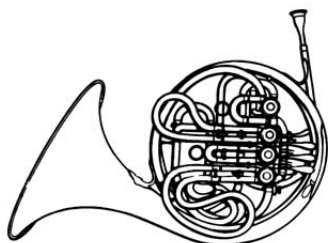

\_\_\_\_\_

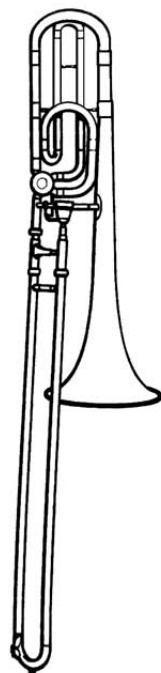

\_\_\_\_\_

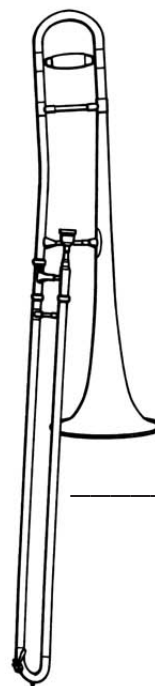

\_\_\_\_\_

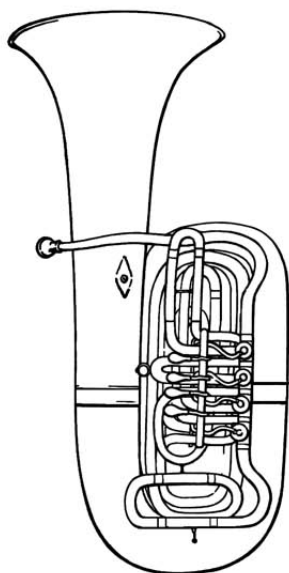

\_\_\_\_\_

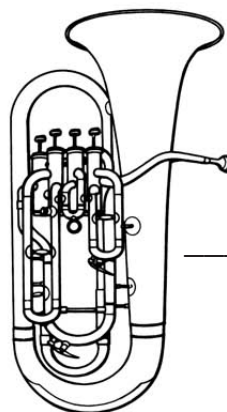

\_\_\_\_\_



# Copywork

Joy to the World! The Lord is come:  
Let earth receive her King.  
Let every heart prepare Him room,  
And heaven and nature sing,  
And heaven and nature sing,  
And heaven, and heaven and nature sing.

Handwriting practice lines consisting of solid top and bottom lines with a dashed midline, repeated 10 times.



# JOY TO THE WORLD

## *crossword*

Complete the crossword below. Use the Bible (ESV) or the lyrics to the song to help you.

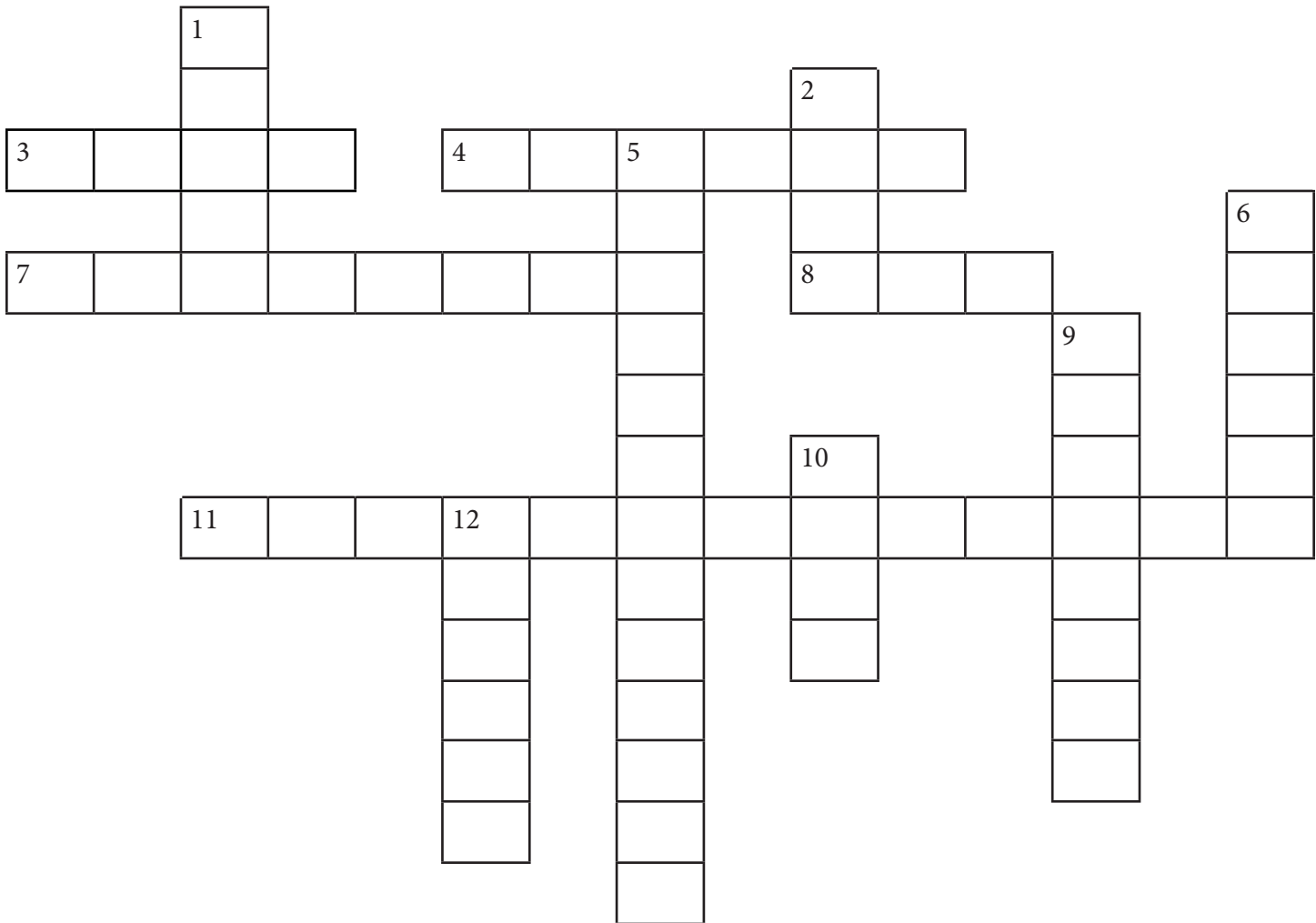

### DOWN

- 1 Joy to the \_\_\_\_\_
- 2 Let earth receive her \_\_\_\_\_
- 5 1 Peter 1:8 says that we will have \_\_\_\_\_ joy.
- 6 Be joyful \_\_\_\_\_  
1 Thessalonians 5:17
- 9 For the joy of the Lord is your \_\_\_\_\_.  
Nehemiah 8:10
- 10 God wants our joy to be \_\_\_\_\_ John 16:24
- 12 And \_\_\_\_\_ and nature sing

### ACROSS

- 3 According to Philippians 4:4, what should we rejoice in?
- 4 Joy is a fruit of the \_\_\_\_\_ Gal. 5:22
- 7 Prov 17:22 says that a joyful heart is good \_\_\_\_\_
- 8 In Romans 15:13, who fills us with joy?
- 11 The kingdom of God is for \_\_\_\_\_ and peace and joy. Romans 14:17

# Extension Activities



Create cards with the word JOY on them and write a Bible verse. Hand them out to people in your neighborhood.



Write the word JOY in huge letters and fill each letter with things you have to be joyful about or things that bring you joy.



Draw or write a list of gifts you can give to Jesus.



Research the 3 kings and draw a Venn Diagram showing what the Bible actually says about them versus what people often say about them.



Write 3 paragraphs telling about the life of Handel.





# O FOR A THOUSAND TONGUES TO SING *the story*

The Wesley brothers sent word to their mother of their conversion, and their mother didn't know what to make of it. "I think you have fallen into an odd way of thinking." She replied, "You say that til within a few months ago you had no spiritual life and no justifying faith... I heartily rejoice that you have attained to a strong and lively hope in God's mercy through Christ. Not that I can think that you were without saving faith before, but it is one thing to have faith, and another thing to be sensible we have it."

Well, Charles Wesley was now very sensible of it. His life was turned around completely, he overcame his temper, and even stopped his drinking habit. "I was amazed to find my old enemy, intemperance, so suddenly subdued, that I almost forgot I was ever in bondage to him."

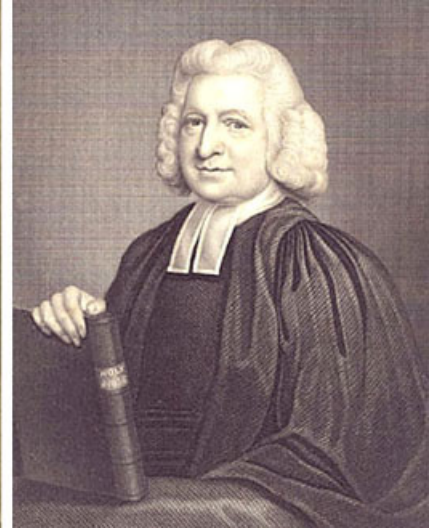

New zeal for Christ filled Charles, and he began to preach everywhere he went. He even stopped using written sermons, preferring to preach what God put on his heart.

He discovered a very fruitful ministry preaching to convicted prisoners. He would allow himself to be locked up with a prisoner sentenced to death, the night before their execution, so he could witness to them and comfort them.

On the first anniversary of his conversion, in 1707, he wrote an eighteen stanza hymn of praise to the Lord. The first phrase of the seventh verse began: "O for a thousand tongues to sing." This was inspired by a statement Charles once heard someone say: "Had I a thousand tongues, I would praise Him with them all."

In a hymn book composed by his brother John, the seventh stanza was made the first and the song was put first in the book. Today we usually sing stanzas seven, eight, nine, and ten, commonly known as "O for a Thousand Tongues to Sing."

Charles Wesley wrote at least 6500 hymns in his lifetime, including many famous hymns you would know like "Hark the Herald Angels Sing" and "Christ The Lord is Risen Today."

# Hymn Study Notes

NAME OF THE HYMN

---

WRITTEN BY

---

YEAR & LANGUAGE THE HYMN WAS WRITTEN

---

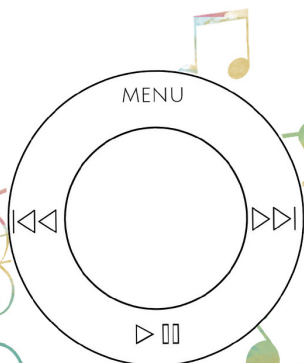

FACTS ABOUT THE AUTHOR



---



---



---



---



---



---

TELL ABOUT THE STORY BEHIND THE HYMN

---

---

---

---

---

---

---



# Bible LESSON

Charles Wesley knew something all Christians need to know. It's one thing to say you have faith and another thing to actually live like you do. Both Paul and James address this problem in the Bible. It's important that we don't get fooled into thinking we must DO something to earn our faith. That's a lie. But, if we really have faith, it will change our lives.

Let's read what James 2:17 and 2:26 say about saving faith. Write what you find.

---

How is your life different because you have faith in God? Think about changes you have made, things you don't do that others do, or even choices you make differently.

---

---

---

As we saw in the life of Charles Wesley, real faith, saving faith, changes our lives. One of those changes is we have a desire to tell others about how good God is and how He can change their lives, too.

Matthew 5:16 is a good verse to read about that since it talks about our "good works" yet again. What does this verse say?

---

---

Now let's see what these two verses have to say about sharing Christ.

1 Peter 3:15 \_\_\_\_\_



Mark 16:15 \_\_\_\_\_

One of my favorites is 1 Timothy 4:10-12 because often we think we are too young or immature to share Christ with others. We think we should know more, be older, or have a fancy degree. This verse encourages quite the opposite. Summarize it below.

\_\_\_\_\_  
\_\_\_\_\_  
\_\_\_\_\_

What are the five things you are to set an example in?

 \_\_\_\_\_  
 \_\_\_\_\_  
 \_\_\_\_\_  
 \_\_\_\_\_  
 \_\_\_\_\_

As you conclude today, pray and ask God to help you see where you can improve with living your life for Him and sharing with others.

\_\_\_\_\_  
\_\_\_\_\_  
\_\_\_\_\_  
\_\_\_\_\_  
\_\_\_\_\_  
\_\_\_\_\_

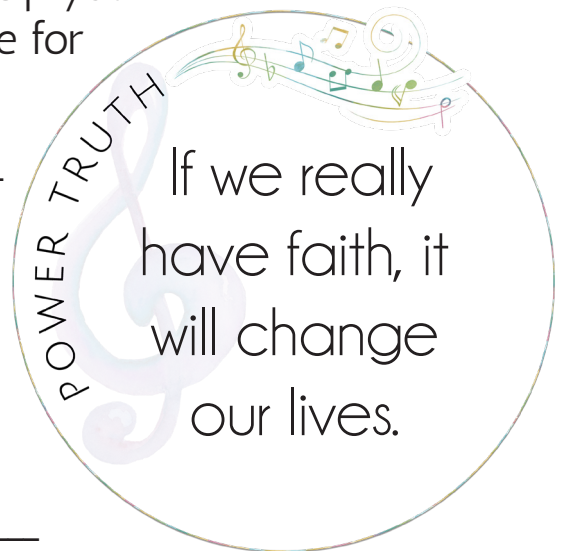





# Music THEORY

- Practice holding the tin whistle properly
- Practice making loud and soft sounds
- Play the D scale
- Play the hymn

Label the percussion instruments.

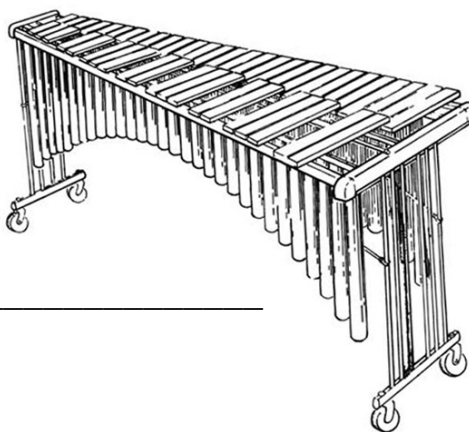
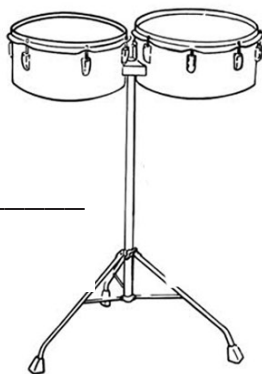
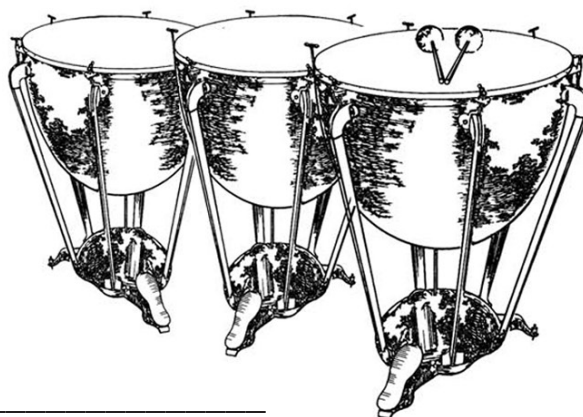



# Copywork

Oh, for a thousand tongues to sing  
My great Redeemer's praise,  
The glories of my God and King,  
The triumphs of His grace!  
My gracious Master and my God,  
Assist me to proclaim,  
To spread through all the earth abroad  
The honors of Thy name.

Handwriting practice lines consisting of multiple sets of solid top and bottom lines with a dashed midline.



# HOW MUCH IS 1000?



Write a few math problems that equal 1000.

Draw one thing you absolutely NEVER want to have 1000 of.

Draw one thing you wish you had 1000 of.

How long would it take you to eat 1000 pieces of candy?



Name 3 places 1000 people could fit.

 \_\_\_\_\_  
 \_\_\_\_\_  
 \_\_\_\_\_

If you had \$1000, what would you buy?

 \_\_\_\_\_  \_\_\_\_\_  
 \_\_\_\_\_  \_\_\_\_\_  
 \_\_\_\_\_  \_\_\_\_\_

Name 3 places 1000 people could NOT fit.

 \_\_\_\_\_  
 \_\_\_\_\_  
 \_\_\_\_\_

Ask your parents to tell you 3 things you can and cannot buy with \$1000.

CAN BUY	CANNOT BUY

# Extension Activities



Research Charles Wesley and write about his ministry.



Take a field trip to a local retirement or nursing home. While there sing songs about Jesus, play hymns, and/or read Scripture passages or devotionals to residents.



Invite a neighbor or friend to go to church or Sunday School with you.



Make a list of hymns Charles Wesley has written. Cut the list into strips and play charades with your family seeing who can guess the hymn being acted out.



Write a six to eight line poem of praise for what God has blessed you with.





# 'TIS SO SWEET TO TRUST IN JESUS *the story*

Louisa M.R. Stead knew what it meant to really trust Jesus. Born in Dover, England, she had put her trust in Him at age nine and even worked through school to become a missionary.

One day in 1882, her trust in Jesus was tested. Louisa and her daughter, Lily, sat on a picnic blanket at a beach in Long Island, NY and watched as her husband heroically attempted to save a young boy who was drowning. Sadly, the boy took Mr. Stead down with him as Louisa and Lily watched in horror.

No longer having any income, they were left broken-hearted, destitute, and starving. Not long after the event, someone dropped off a lavish meal at the doorstep of Louisa and her daughter. That night as she rejoiced over the provision of the Lord that day, she penned the words of "Tis So Sweet To Trust in Jesus."

Keeping with her dream to become a missionary, Louisa and Lily eventually moved to South Africa to serve God. Louisa wrote, "In connection with this whole mission there are glorious possibilities. One cannot, in the face of the peculiar difficulties, help saying, 'Who is sufficient for these things?' But with simple confidence and trust we may and do say, 'our sufficiency is of the Lord.'"

She and her second husband spent the rest of their lives in ministry. This beautiful hymn is not only found in hymnals around the country, it's still a cherished part of the Zimbabwe culture where Louisa and her family served.



# Hymn Study Notes

NAME OF THE HYMN

---

WRITTEN BY

---

YEAR & LANGUAGE THE HYMN WAS WRITTEN

---

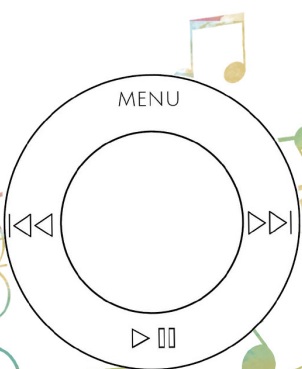

FACTS ABOUT THE AUTHOR



---



---



---



---



---



---

TELL ABOUT THE STORY BEHIND THE HYMN

---

---

---

---

---

---

---



# Bible LESSON

The story of this hymn writer reminds me of a story in the Bible. Let's read it in 1 Kings 17:8-16. Answer the questions below.

Who is the story about? \_\_\_\_\_  
What did Elijah ask for?

---

---

Why was this a problem for the widow?

---

---

---

---

Can you imagine giving the last bit of food you had to someone else? Most of us have probably never done anything like that. But you might have been faced with a time when you had to trust God with your needs. If you have, tell about it below.

---

---

---

Now let's go back and read the ending of the story in 1 Kings 17:16. Because the widow trusted God, what happened?

---

---



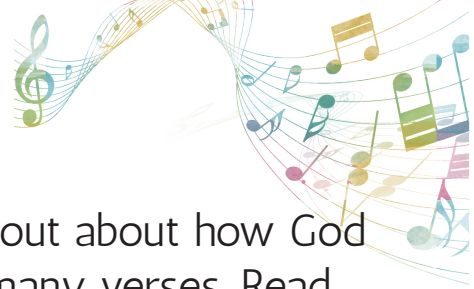

Let's do a survey of the Bible and see what we can find out about how God provides for our needs. A survey is just a quick look at many verses. Read each verse and record what you learn below.

Philippians 4:19 \_\_\_\_\_

Matthew 6:26 \_\_\_\_\_

Psalms 81:10 \_\_\_\_\_

Psalms 34:10 \_\_\_\_\_

2 Peter 1:3 \_\_\_\_\_

Psalms 84:11 \_\_\_\_\_

Let's end today by making a list of things in your life you need to trust God with. They can be little things and big things. There are many you could put on this list, but focus on the ones you struggle with the most.

 \_\_\_\_\_

 \_\_\_\_\_

 \_\_\_\_\_

 \_\_\_\_\_

 \_\_\_\_\_

 \_\_\_\_\_

 \_\_\_\_\_

 \_\_\_\_\_

End today by praying over your list and asking God to help you with each one.





- 🎵 Practice holding the tin whistle properly
- 🎵 Practice making loud and soft sounds
- 🎵 Play the D scale
- 🎵 Play the hymn

REVIEW: Label each instrument group with their correct family name.

<p>_____</p>	<p>_____</p>
<p>_____</p>	<p>_____</p>

Which group is your favorite and why?

---



---



---



# Copywork

'Tis so sweet to trust in Jesus,  
Just to take Him at his word,  
Just to rest upon His promise,  
Just to know, "Thus saith the Lord."  
Jesus, Jesus, how I trust Him!  
How I've proved Him o'er and o'er!  
Jesus, Jesus, precious Jesus!  
O for grace to trust Him more.

Handwriting practice lines consisting of multiple sets of solid top and bottom lines with a dashed midline.

Voyage to Africa Instructions: Draw the path Louisa and Lily would have taken to Africa from New York. Draw the vehicle they would have traveled in.

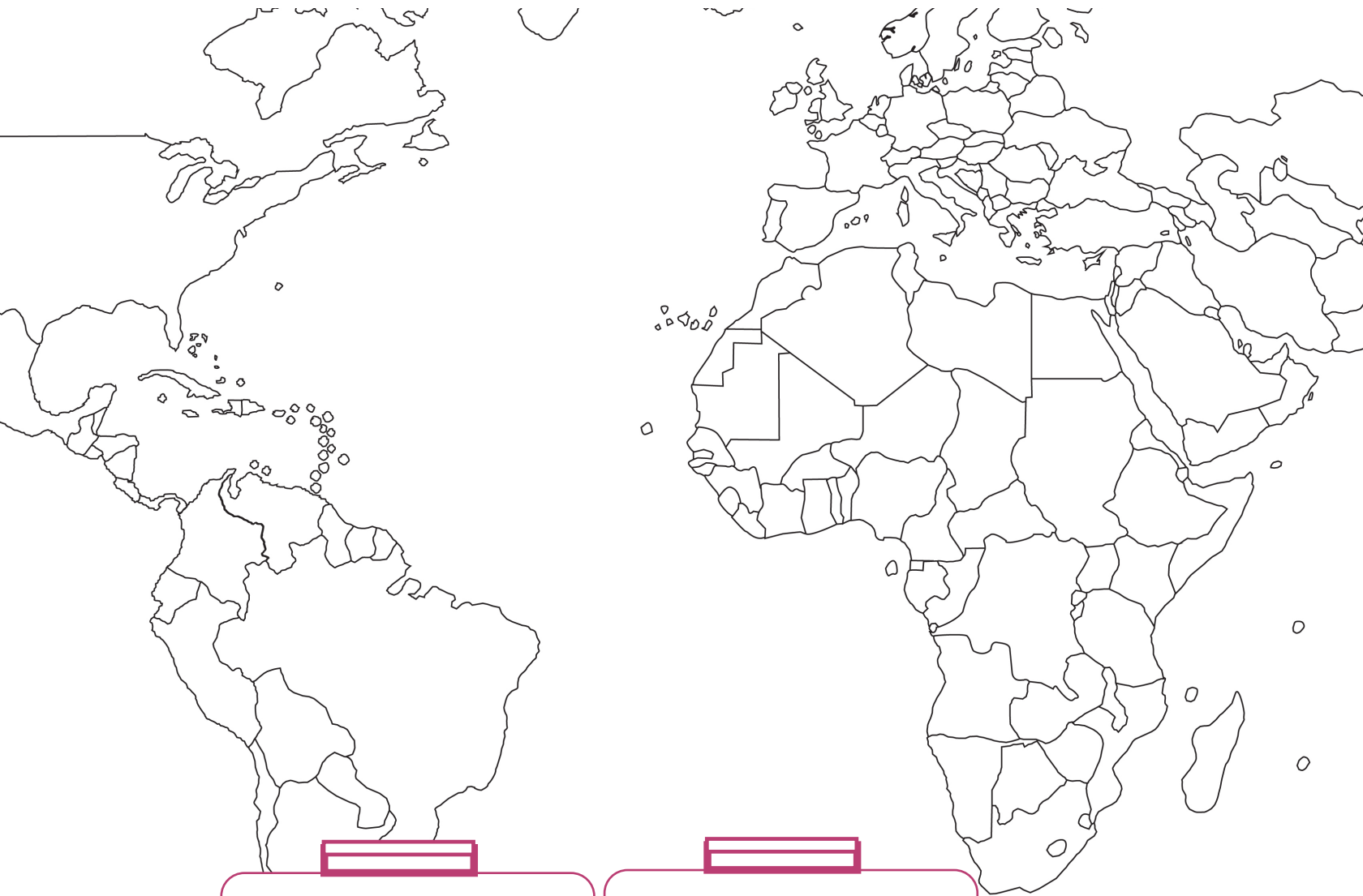

How long would this journey have taken in 1882?

How long would this journey take today?

What do you think the journey was like?

---

---

---

---

# Extension Activities



Make a photo collage of what God has provided for you and you trust Him to provide.



Research the life of George Muller. Who was he and what did he trust God to provide? Write a few paragraphs about what you find.



Help your mom prepare and deliver a meal to a family in need.



Find Zimbabwe on a map or globe. Calculate how many miles it is from where you live and how long it might take to get there.



Find 5 promises that God has given in His Word. Write them down and next to each one draw a picture of how He has done this in your life.





# TURN YOUR EYES UPON JESUS

*the story*

Helen Howarth Lemmel was born in England in 1863, but immigrated to America when she was 12. Her love of music was evident from a young age, and her parents provided vocal lessons for her. Throughout adulthood, music became her life as she studied music in Germany, taught at Moody Bible Institute, and served as a music critic for the *Seattle Post*.

While Helen did marry, her husband left her when she became blind, causing her to focus even more on her music. In her life, she wrote over 500 hymns including the most famous, "Turn Your Eyes Upon Jesus."

Originally written for Billy Sunday's evangelistic crusade in 1922, this hymn was inspired by a tract written by Lilius Trotter, a missionary to Algeria. Lilius was seeking to offer a prescription for keeping your life on track and helping Christians make wise decisions. The words read:

*Turn your soul's vision to Jesus, and look and look at Him,  
and a strange dimness will come over all that is apart from Him.*

"I stood still," Helen later said, "and singing in my soul and spirit was the chorus, with not one conscious movement of putting word to word to make rhyme, or note to note to make melody. The verses were written the same week after the usual manner of composition, but nonetheless dictated by the Holy Spirit."

One of Helen's favorite things was the small plastic keyboard by her bed. With it she would play, sing, and cry. She said "One day God is going to bless me with a great heavenly keyboard. I can hardly wait!"



# Hymn Study Notes

NAME OF THE HYMN

---

WRITTEN BY

---

YEAR & LANGUAGE THE HYMN WAS WRITTEN

---

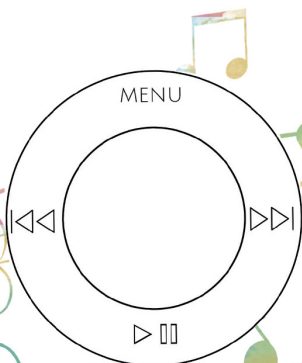

FACTS ABOUT THE AUTHOR



---



---



---



---



---



---

TELL ABOUT THE STORY BEHIND THE HYMN

---

---

---

---

---

---

---



# Bible LESSON

The story of "Turn Your Eyes Upon Jesus" is a great encouragement for us to stay focused on the things that really matter in this life. Although we don't know if the writer used any particular verses for inspiration, there are many addressing this topic.

Let's read Colossians 3:1 - 3. Write out verse 2 below.



This verse tells us very specifically what we are supposed to focus on. Depending on the translation you read, it says to set your "minds" or "affections" on things above. I love both of these words.

What do you think it looks like to set your mind on Christ?

What would it look like to set your affections on Christ? (Hint: look up the word affections in the dictionary.)

Read Hebrews 12:1. Again it's telling us to do what?

One key to making sure we stay focused on what matters in life is getting rid of the things that distract us, harm us, or pull us away from our focus.



What are some things in your life that make it hard to stay focused on Jesus?



\_\_\_\_\_



\_\_\_\_\_



\_\_\_\_\_



\_\_\_\_\_



\_\_\_\_\_



\_\_\_\_\_



\_\_\_\_\_



\_\_\_\_\_

When you look at the list you made above, I imagine it's discouraging. Keeping these things out can be hard. We are tempted, and we sometimes fail. However, we don't have to do this all on our own.

Read the verse right after the one we read a minute ago, Hebrews 12:2. According to this verse, how can we lay aside the weights that are keeping us from Jesus and the things in life that steal our focus?





\_\_\_\_\_  
\_\_\_\_\_

What a wonderful promise! Close your study today by praying and thanking God for giving you the strength to focus on Him. Pray over the things you listed and ask Him to help you "lay them aside" in order to seek first the things above!





# Music THEORY

-  Practice holding the tin whistle properly
-  Practice making loud and soft sounds
-  Play the D scale
-  Play the hymn



Crescendo







CRESCENDO is an indication to gradually increase the volume of a song until otherwise noted.







Decrescendo

DECREScendo is an indication to gradually decrease the volume of the music.

Write the correct term for each symbol in the space provided.

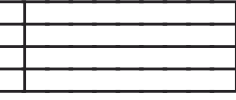
	
	
	
	
	
	
<i>mf</i>	
	

<i>p</i>	
	
	
<i>f</i>	
	
	
	
<i>mp</i>	



# Copywork

O soul, are you weary and troubled?  
No light in the darkness you see?  
There's light for a look at the Savior  
And life more abundant and free.  
Turn your eyes upon Jesus,  
Look full in His wonderful face,  
And the things of earth will grow strangely dim  
In the light of His glory and grace.

Handwriting practice lines consisting of solid top and bottom lines with a dashed midline, repeated 10 times.



# Extension Activities



Wearing a blindfold, use a set of keys and try to unlock your front door. Draw or write about how this shows you why it's important to keep your eyes on Jesus.



Make a photo collage of things that take up your time; activities, video games, tv, reading, etc. Cut a large cross out of construction paper. Write on it some things Christ has done for and given you. Glue on top of the collage.



Write down 7 words from the hymn story and find synonyms for those words.



Learn about what it would be like to work for a newspaper or for another company you might be interested in working for. Give an oral report to your family at dinner.



Learn about Billy Sunday and write a news story sharing the impact he had on Christians.





# I STAND AMAZED IN THE PRESENCE

*the story*

Most hymns have two authors: the person who wrote the lyrics and the person who wrote the tune. Generally, the person who wrote the lyrics is the one given credit. "I Stand Amazed" is an exception to this trend as its author, Charles H. Gabriel, wrote the lyrics and composed the music himself. In fact, he did this for over 7000 songs, 35 gospel collections, 41 Christmas cantatas, and many other Sunday School song books and collections. He was so popular he became known as the "king of gospel music."

Contrary to his popularity and talent, Charles lived a simple and humble life. He was raised on a farm in Iowa where his father taught singing in their home. Naturally, Charles grew fond of music. He taught himself how to play his family's reed organ and by his teen years was teaching singing on his own while composing hymns for his local church.

Before long, his hymns were in high demand from pastors like Billy Sunday and Homer Rodeheaver. Said to have been a prodigy in his time, Charles heard music in his head and composed it almost as easily as most people breathe.

"I Stand Amazed in the Presence" was written in 1905 and first published in E.O. Excell's collection, *Praises*. It is sometimes found in hymnals with the title, "My Savior's Love." This hymn clearly demonstrates a beautiful humility in the life of Charles Gabriel. He was not self-absorbed like so many others would have been, but instead marveled at his God-given talent with deep gratitude. Even with his incredible popularity and success as a hymn writer, Charles still knew he was a sinner just like everyone else, condemned and unclean.

The exact inspiration of this hymn is unknown. However the Rev. Carlton R. Young, editor of *The United Methodist Hymnal*, recorded it to be based on the story of Jesus in the Garden of Gethsemane. When you read the lyrics, it's easy to see why this assumption was made.

Other well known hymns written by Charles Gabriel include: "Send the Light the Blessed Gospel Light," "His Eye is On The Sparrow," "Will the Circle Be Unbroken," and "O That Will Be Glory for Me."



# Hymn Study Notes

NAME OF THE HYMN

---

WRITTEN BY

---

YEAR & LANGUAGE THE HYMN WAS WRITTEN

---

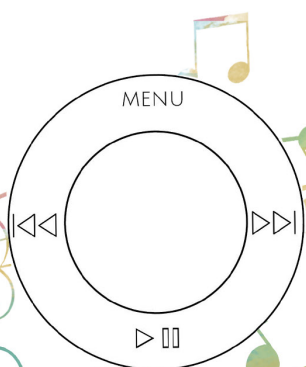

FACTS ABOUT THE AUTHOR



---



---



---



---



---



---

TELL ABOUT THE STORY BEHIND THE HYMN

---

---

---

---

---

---

---



# Bible LESSON

Read Luke 22:41-44 and compare it with the second verse of the hymn below. How does this show God's love for you?

*For me it was in the garden  
he prayed: "Not my will, but thine."  
He had no tears for his own griefs,  
but sweat-drops of blood for mine.*

---

---

In the chorus, you'll see the word "marvelous" repeated over and over again. Using a dictionary, define marvelous.

---

---

---

---

What is the MOST marvelous and wonderful thing God has done for us? (Hint: this hymn tells you all about it.)

---

---

What are some other marvelous things God has done for you and your family?

---

---

---

There are so many verses in the Bible that tell of God's love for us. Let's do another Bible survey and look up each verse in each heart. Under the reference, write a key word or phrase that tells about God's love.



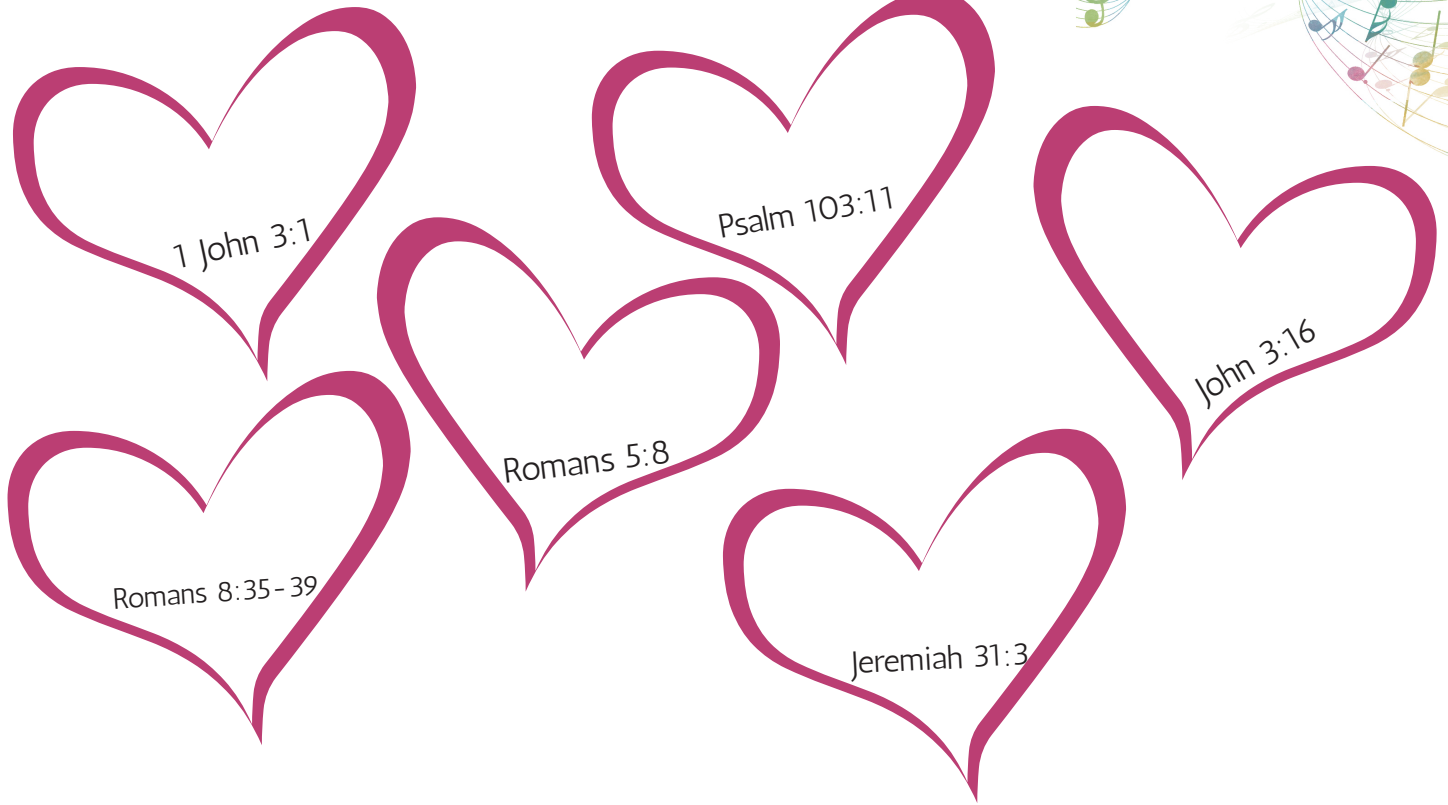

## Why should we love?

1 John 4:19 says we love because \_\_\_\_\_

1 Peter 4:8 says love covers \_\_\_\_\_

1 John 4:7 says if we know God we will \_\_\_\_\_

## How should we love?

1 John 5:3 says we can love God by keeping \_\_\_\_\_

Mark 12:30 says to love with \_\_\_\_\_

Proverbs 17:17 says to love at \_\_\_\_\_

Mark 12:31 says to love your neighbor as \_\_\_\_\_

Close today by praying and thanking God for His love. Use some of the verses above to specifically thank Him for this marvelous gift He has given us.







# Copywork

I stand amazed in the presence  
of Jesus the Nazarene,  
and wonder how He could love me,  
a sinner, condemned, unclean.  
How marvelous! How wonderful!  
And my song shall ever be:  
How marvelous! How wonderful  
is my Savior's love for me!

Handwriting practice lines consisting of multiple sets of solid top and bottom lines with a dashed midline.



# TURN YOUR EYES UPON JESUS

Unscramble the following words from today's lesson:

- 1. elsopg \_\_\_\_\_
- 2. nreepsce \_\_\_\_\_
- 3. eissrap \_\_\_\_\_
- 4. eritgtuad \_\_\_\_\_
- 5. egnrad \_\_\_\_\_
- 6. ameshneget \_\_\_\_\_
- 7. soruleamv \_\_\_\_\_
- 8. damzea \_\_\_\_\_
- 9. cerhasl \_\_\_\_\_
- 10. nfedrwulo \_\_\_\_\_
- 11. zanenear \_\_\_\_\_
- 12. ligbear \_\_\_\_\_
- 13. riscyl \_\_\_\_\_
- 14. ylmhna \_\_\_\_\_
- 15. ooecdsmp \_\_\_\_\_

## WORD BANK

amazed	presence	hymnal	Charles	garden
composed	gospel	Gabriel	praises	gratitude
Gethsemane	wonderful	Nazarene	lyrics	marvelous

# Extension Activities



Choose a word you don't know from the hymn story and define it.



Research what a reed organ is and draw a picture of it.



Make and deliver a few valentine cards for elderly people in your church.



If you play a musical instrument, consider playing music or singing a song for church or children's ministry.



Learn about the life of Billy Sunday and write a paragraph telling why he inspires you.





# BE THOU MY VISION

*the story*

Perhaps the oldest hymn found in our hymnals today, "Be Thou My Vision" was written during the 5th or 6th century in Ireland. It is believed to have been written by St. Dallán, an Irish poet and scholar. His name means "little blind one" as Dallán became blind early in life. The poem he wrote in Irish looked like this...

*Rob tu mo bhoile,  
a Comdi críde.  
Ni ni nech aile,  
acht ri secht  
nime ...*

Wishing to seek God's vision for his life, both physically and spiritually, St. Dallán was inspired by a hymn written by Saint Patrick, known as "Saint Patrick's Breastplate" or "Saint Patrick's Lorica," which tells about the protection of God.

It's easy to see why St. Dallán was inspired by the work of St. Patrick. Born in 373 A.D.

in the rolling hills of Scotland, the church was in St. Patrick's blood. His father was a deacon and his grandfather a priest. One dreadful day when St. Patrick was sixteen, pirates raided his village and burned his home. He was seized and taken away to Ireland as a slave. It was there that he gave his life fully to the Lord.

After escaping and returning home, St. Patrick had a dream very similar to Paul's vision of the Macedonian man in Acts. His dream showed an Irish man asking him to come back to Ireland to evangelize. It wasn't an easy choice to make, but St. Patrick decided to travel back to Ireland around the age of thirty. He preached with zeal, although he faced great persecution during that time. Even under the threat of death, St. Patrick's teachings were powerful, and he was known as one of the most successful evangelists of all time, planting over 700 churches and baptizing over 100,000 people.

In 1905, over a thousand years after St. Dallán and St. Patrick wrote the words, Mary Elizabeth Byrne translated this ancient poem to English. In 1912, Eleanor Hull took the translation and turned it into the song we know today.

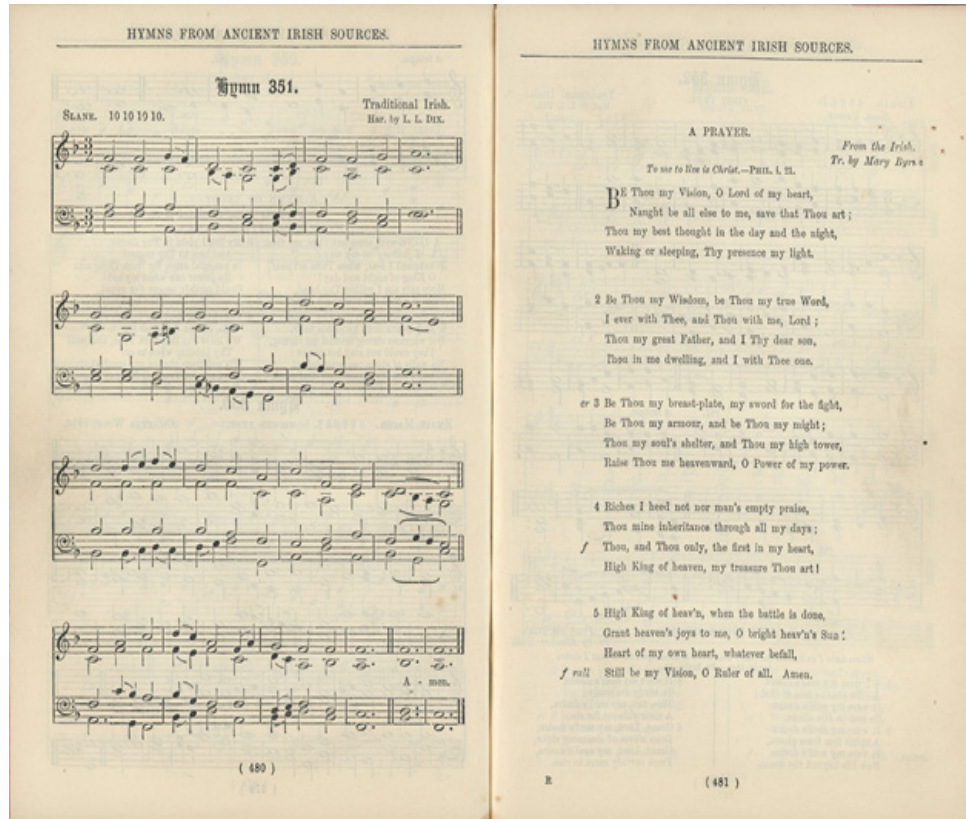

# Hymn Study Notes

NAME OF THE HYMN

---

WRITTEN BY

---

YEAR & LANGUAGE THE HYMN WAS WRITTEN

---

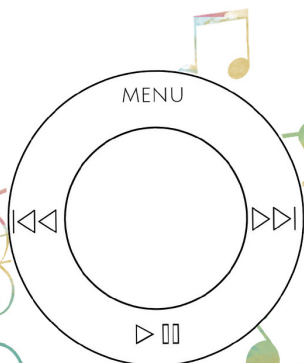

FACTS ABOUT THE AUTHOR



---



---



---



---



---



---

TELL ABOUT THE STORY BEHIND THE HYMN

---

---

---

---

---

---

---



# Bible LESSON

When we studied "Turn Your Eyes Upon Jesus" we talked about how easy it is for Christians to become focused on the things of the world instead of the things of God. "Be Thou My Vision" encourages us in this same way.

The verses ask God to be our vision, our best thought, and our wisdom, which reminds me of Ephesians 1:17-23. What words or phrases do you see in this passage that are similar to the lyrics of "Be Thou My Vision"?

---

---

---

Read James 3:17 and write the words that describe the wisdom of God in the glasses below. Be creative with your letters and have fun.

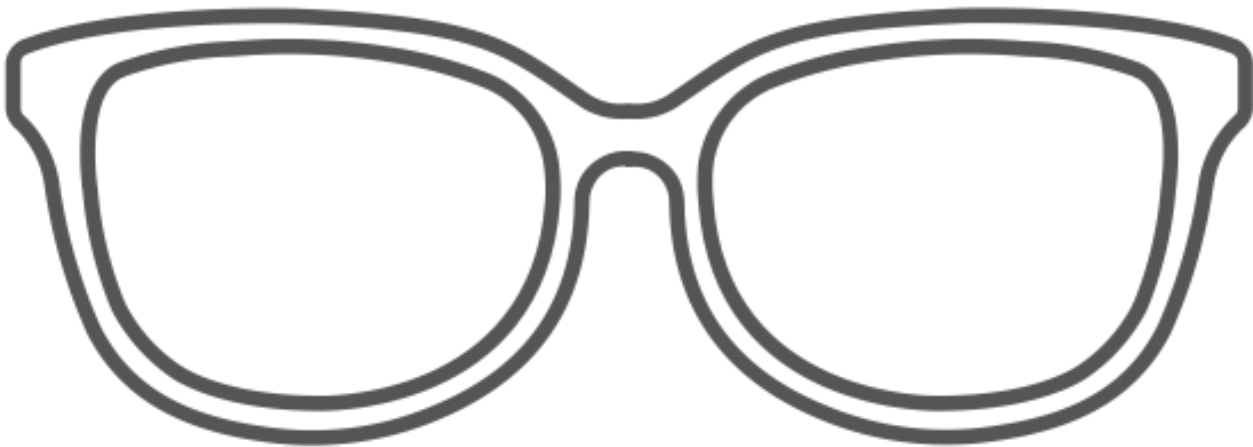

Life brings us many situations where we don't know what to do. Sometimes there are just too many choices and sometimes the choices are too difficult to pick from. It can easily become discouraging as we try to decide. This can happen with a simple thing like what to eat for breakfast or what to wear to church. It can also happen with really hard things like what to do when a friend asks us to do the wrong thing or future decisions like where to go to college.

Have you ever faced a big decision where you didn't know what to do? Write about it.

---

---

---



Flip over a few pages to James 1:5. What does God promise us in this verse?

---

---

---

No matter how hard the decision is, God will always give us the wisdom we need... IF we seek Him for it. Let's look up another important verse on this topic, Proverbs 3:7. What does the Bible warn us NOT to do?

---

---

It's tempting to think we can do things on our own, but this is a very dangerous trap to fall into. Being "wise in our own eyes" is a quick path to destruction as our hearts can't be trusted. Only God can be trusted.



Psalm 146:3 says not to trust \_\_\_\_\_

because with MAN it is \_\_\_\_\_ to be saved (see Matthew 19:26). But with God \_\_\_\_\_ are possible!

End today by writing a prayer to God below, asking Him to be the vision of your life, guiding you and helping you with every decision and every step you take on the path of life.

---

---

---





---

---





---





-  Practice holding the tin whistle properly
-  Practice making loud and soft sounds
-  Play the D scale
-  Play the hymn

Write the name of each ice cream in the matching rhythm box

chocolate butter pecan strawberry rocky road goo goo cluster pumpkin pie cheesecake rum raisin maple nut cotton candy just fudge chocolate chip french vanilla passionfruit praline pecan cherry chocolate almond coffee		
		





# Copywork

Be Thou my Vision, O Lord of my heart;  
Naught be all else to me, save that Thou art;  
Thou my best Thought, by day or by night,  
Waking or sleeping, Thy presence my light.

Handwriting practice lines consisting of multiple sets of solid top and bottom lines with a dashed midline.

# EXPLORING IRELAND

Find Ireland on the map and color it green. Color Scotland purple. Draw St. Patrick traveling from Scotland back to Ireland.



## 5 FACTS ABOUT IRELAND

---

---

---

---

---

---

WOULD YOU LIKE TO VISIT IRELAND? TELL WHY OR WHY NOT.

---

---

---

---

---

---

---

---



# Extension Activities



If you could meet one of the people from today's lesson, what would you like to ask him or her?



Learn more about the time period St. Patrick preached in Ireland. What types of persecution might he have faced? Share this information at dinner.



Watch a YouTube video with your parents about Ireland today.



Would you have gone to Ireland like St. Patrick did? Write a letter to your parents giving your answer and defending it with valid reasons.



Choose 3 words from the lesson and write several rhyming words for each of them.





# STAND UP, STAND UP FOR JESUS

*the story*

Dudley Tyng served as his father's assistant at Philadelphia's Church of the Epiphany, and therefore was elected as pastor when his father retired in 1854. At the young age of thirty, it seemed to be a great fit. But everything changed when he began to preach on slavery. Loud disapproval caused him to "resign" in 1856.

He and a few of his loyal followers created the Church of the Covenant in a different part of the city, and his reputation grew. He began to hold Bible studies at the YMCA, and his ministries grew beyond the walls of his church. Dudley was especially drawn to teaching men, and helped organize a men's rally.

On Tuesday, March 30, 1858, five thousand men gathered together for a revival led by Dudley along with other well-known pastors in the area. Looking over the sea of faces, he felt overwhelmed.

"I would rather this right arm were amputated at the trunk than I should come short of my duty to you in delivering God's message," he told the crowd. Over 1000 men were saved that day.

Days later while visiting the countryside, Dudley patted a mule pulling a corn-thrasher in the field. His sleeve was caught, his arm was jerked from its socket and the main artery was severed. Infection would take his life within days. When it appeared he was going to die, Dudley whispered these words to his father: "Stand up for Jesus, Father, and tell my brethren of the ministry to stand up for Jesus."

A friend and fellow preacher, Rev. George Duffield of Philadelphia's Temple Presbyterian Church, was so deeply moved by those words, the next Sunday he preached about standing firm for Christ based on Ephesians 6:14. He concluded his sermon with a hymn he had written that was inspired by Dudley's words. These words became the first stanza of "Stand Up, Stand Up for Jesus," one of America's favorite hymns.



# Hymn Study Notes

NAME OF THE HYMN

---

WRITTEN BY

---

YEAR & LANGUAGE THE HYMN WAS WRITTEN

---

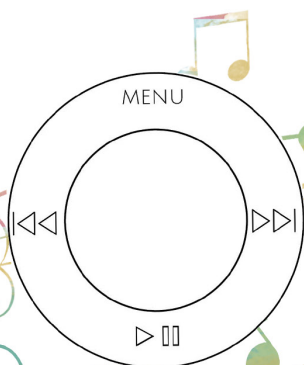

FACTS ABOUT THE AUTHOR



---



---



---



---



---



---

TELL ABOUT THE STORY BEHIND THE HYMN

---

---

---

---

---

---

---



# Bible LESSON

On the day he wrote this hymn, author George Duffield preached a sermon on Ephesians 6:10 - 24. Read this passage carefully. On the shield below, write words you see both in Ephesians 6 and in "Stand Up, Stand Up for Jesus."

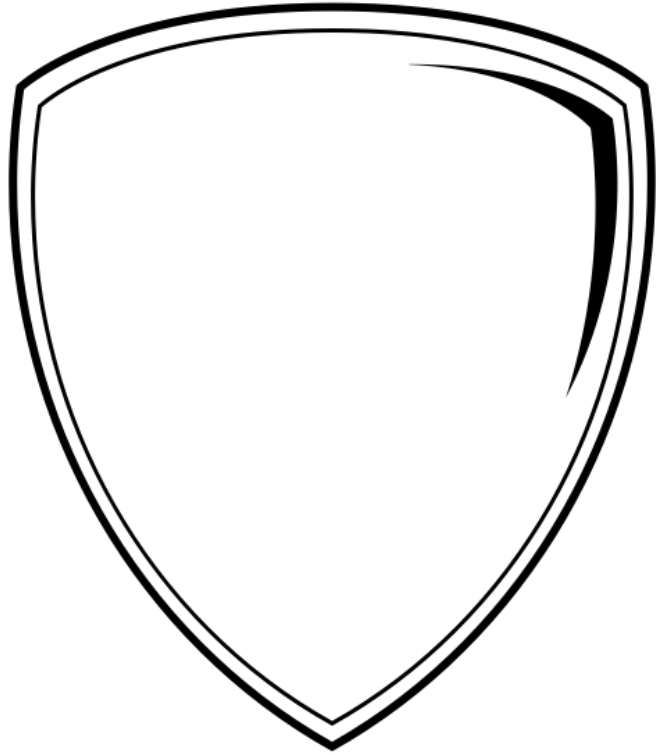

Like the dying words of Dudley Tyng, the Bible tells us to STAND FIRM against evil. In Ephesians 6 we see very specific instructions for how to do this. Fill in the chart below to describe each part of this armor.

VERSE	ITEM	BENEFIT
v.14	belt	truth

Dudley was a very brave pastor. In a time when it wasn't popular to speak out against slavery, he did it anyway. He wanted to please God more than he wanted to please man. But I assure you this wasn't easy. Standing up for Jesus can be very hard.

Tell about a time when you stood up for what was right even when it was hard or tell about a time when you should have.



---

---

---

---

There were many people in the Bible who faced great danger because they stood up for Jesus. One of those people was Paul. Read the verses below and record what you learn in each one.

Romans 1:16 \_\_\_\_\_

2 Timothy 1:8 \_\_\_\_\_

1 Peter 4:16 \_\_\_\_\_

Let's close our lesson today by considering your part. Do you need to do a better job at standing firm for Jesus and putting on your armor?

---

---

---

---



Which parts of your armor do you forget or struggle to cling to?

---

---

Are you willing to stand for Jesus, no matter what people think? Write a prayer to Him about that now and list the specific ways you can do this in your life today.

---

---

---

---

---





- Practice holding the tin whistle properly
- Practice making loud and soft sounds
- Play the D scale
- Play the hymn

Decode the secret words by writing the letter name of each note

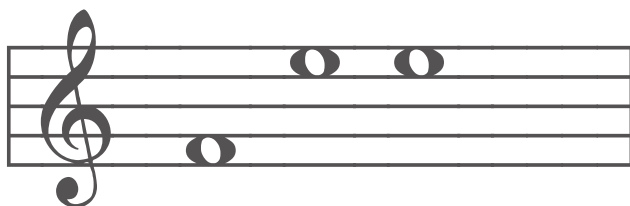
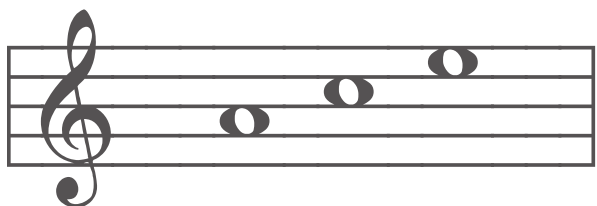
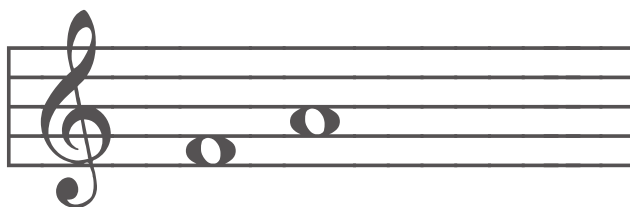
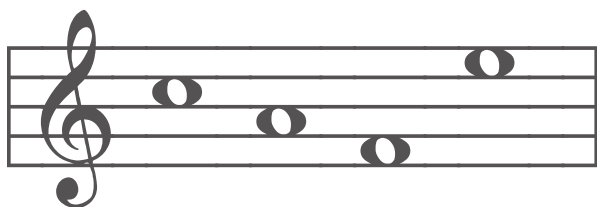
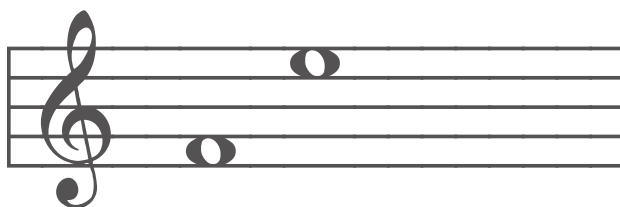
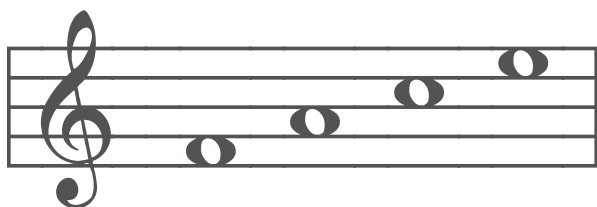



# Copywork

Stand up, stand up for Jesus, ye soldiers of the cross;  
Lift high His royal banner, it must not suffer loss.  
From victory unto victory His army shall He lead,  
Till every foe is vanquished, and Christ is Lord indeed.

Handwriting practice lines consisting of 10 sets of three horizontal lines (top, middle dashed, bottom) for copying the text above.



Draw 5 places where you can stand up for Jesus.

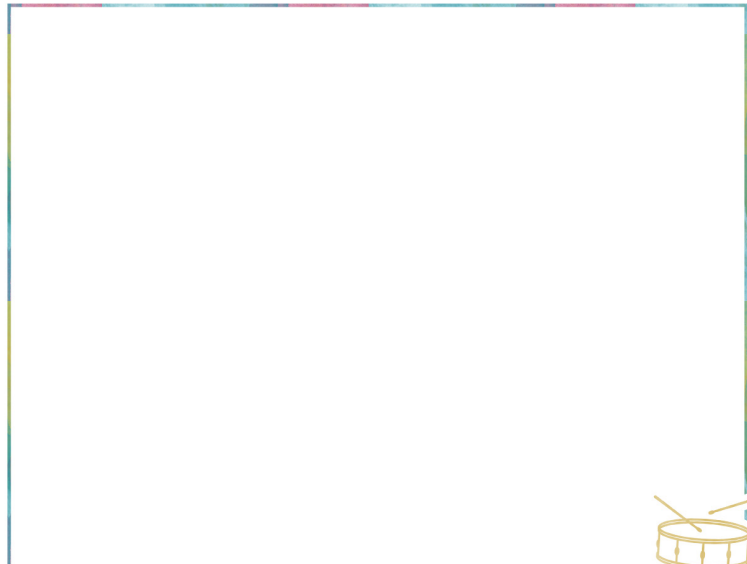
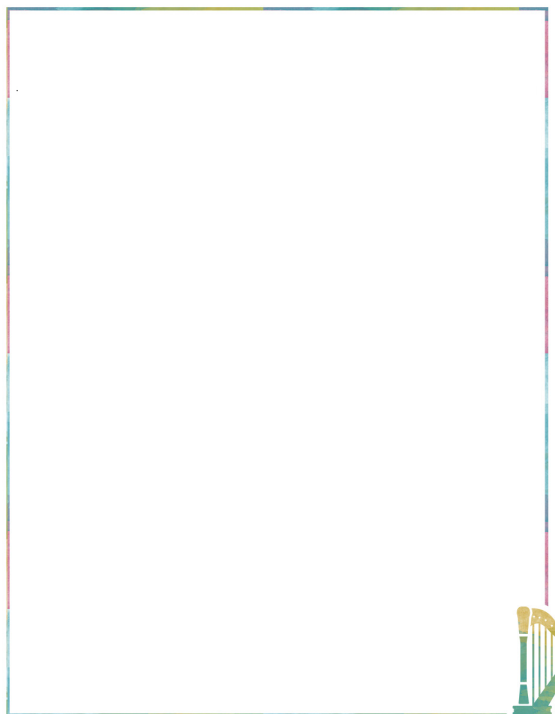
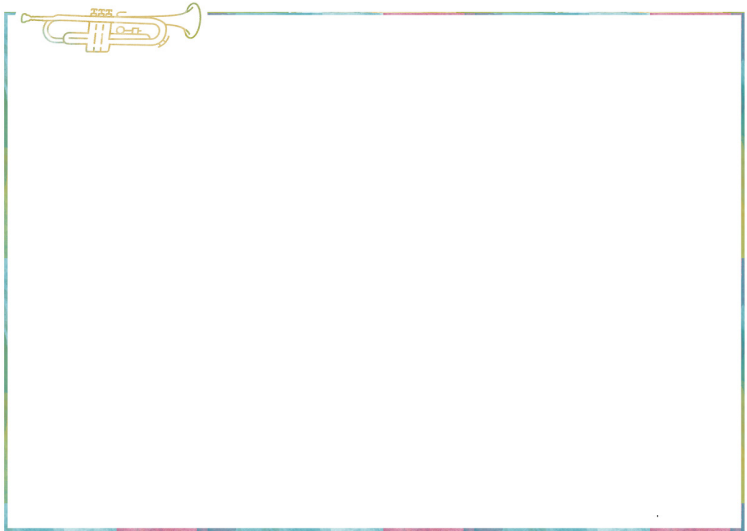
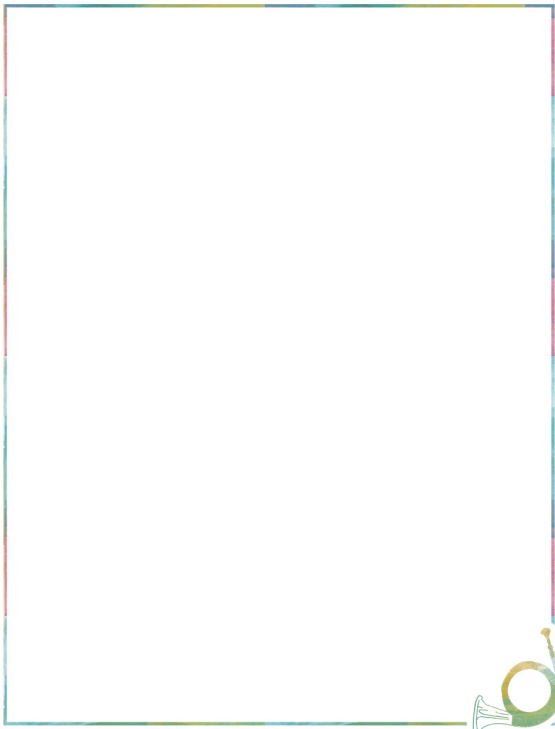

# Extension Activities



Find 3 nouns, 3 verbs, and 3 adjectives in the hymn story.



Read the story of Rachel Scott who was killed in the Columbine school shooting. Express how this story moves you to stand up for what you believe in.



Write out and share your testimony in front of your Sunday School class or youth group.



Find 3 other people throughout history who were persecuted for their beliefs. Create a graphic showing who they were and what they stood for.



What is a choice that Dudley Tyng had to make? Write how that affected his life.





# COME, THOU FOUNT OF EVERY BLESSING

*the story*

Robert Robinson had a rough start to his life. Because they had no other way to earn money, his mother sent him to London to work as an apprentice after his father died. Immature and unruly, Robert became involved in gang life and drunkenness. One night his friends committed a cruel crime against a fortune teller who, despite the horrible abuse, spoke a weird blessing of sorts over Robert. She mentioned that he would be alive to see his children and grandchildren. This bothered him greatly as he realized his life was not fit to have a family.

Ready to turn his life around, Robert attended an evangelistic meeting held by George Whitefield, one of history's greatest preachers. That night, he chose to preach from Matthew 3:7: "But when he saw many of the Pharisees and Sadducees coming to his baptism, he said to them, 'You brood of vipers! Who warned you to flee from the wrath to come?'" Bursting into tears, Whitefield exclaimed, "Oh, my hearers! The wrath to come! The wrath to come!"

Immediately, Robert sobered up and felt like Whitefield was preaching only to him. For three years the preacher's words haunted him, until December 10, 1755, when he gave his heart to Christ.

At the age of 20, Robert became a minister of the Calvinist Methodist Chapel. One Sunday in 1758, he wrote a hymn for his sermon on Pentecost Sunday. The song, "Come, Thou Fount of Every Blessing," was a prayer for the Holy Spirit to flood into people's hearts with His streams of mercy and for Christians to remain faithful to God.

It's been said that Robert struggled the most with consistency in his walk with the Lord, changing his denomination many times and fumbling with what he believed. The words of the hymn, "prone to wander," were his personal testimony. He once encountered a woman on a stagecoach who asked him what he thought of the hymn she was singing. He told her, "Madam, I am the poor unhappy man who wrote that hymn many years ago, and I would give a thousand worlds, if I had them, to enjoy the feelings I had then."

"Come, Thou Fount of Every Blessing," has been a favorite hymn for hundreds of years, reminding us that our hearts are indeed prone to wander, but God is merciful and unchanging. What a beautiful truth to cling to.



# Hymn Study Notes

NAME OF THE HYMN

---

WRITTEN BY

---

YEAR & LANGUAGE THE HYMN WAS WRITTEN

---

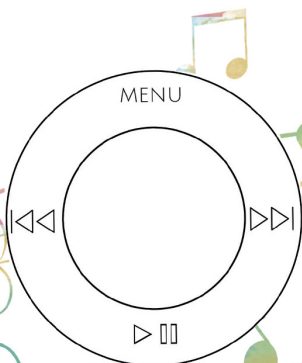

FACTS ABOUT THE AUTHOR



---



---



---



---



---



---

TELL ABOUT THE STORY BEHIND THE HYMN

---

---

---

---

---

---

---



# Bible LESSON

Like Robert Robinson, many Christians find it hard to stay faithful. Our hearts do wander. We get distracted with wanting things, doing things, playing things. We become taken with the beauty and lure of the world and yes, we wander. Do you know why?

Let's read Romans 7:21 - 23. These are the words of Paul. What does he say is the problem even when we want to do right?

---

---

Another truth we should know is Isaiah 53:6. Write that verse below.

---

---

---

Go back and circle WHO the verse is talking about. It's important for us to remember we all wander and stray away from God. In our own abilities, we aren't even capable of doing good. We NEED God.

Read Jeremiah 17:9 and write the truth in the heart.

I find the story of King David to be very encouraging. We first meet him on the battlefield, willing to take on a giant in the name of the Lord. We then find him hiding in caves to save himself from the wrath of Saul before finally taking his place on the throne of Israel. It would seem he was faithful to God, bold and brave. But you know what? David desperately wandered like the rest of us.



Psalms 51 is a psalm of repentance over David's most

wretched sin. Read verses 1 - 4. What is his attitude?

---

---

---

---

---

The Bible describes David as a man after God's own heart, not because he was perfect, but because he was teachable, faithful, and repentant when he did wander. Even though he knew he'd sometimes fail, his greatest desire was to please God. Let's read Psalm 119:9 - 11. These verses offer the secret to David's relationship with God.



How do you keep your way pure? (v. 9) \_\_\_\_\_

---

---

---

Write verse 10 here.

How did David seek God? Circle the words from what you wrote above. Then read verse 11. What can we do to help us not sin against God?

---

End today by taking an honest assessment of yourself. Are you storing up God's Word in your heart (memorizing it)? Are you seeking Him with your whole heart (spending time with Him, praying)? Write your confession below and your prayer asking God to help you not wander from His commandments.

---





---

---

---





-  Practice holding the tin whistle properly
-  Practice making loud and soft sounds
-  Play the D scale
-  Play the hymn

Decode the secret words by writing the letter name of each note

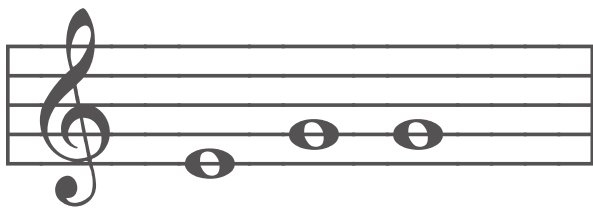

\_\_\_\_\_

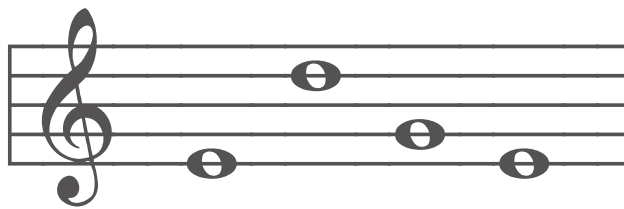

\_\_\_\_\_

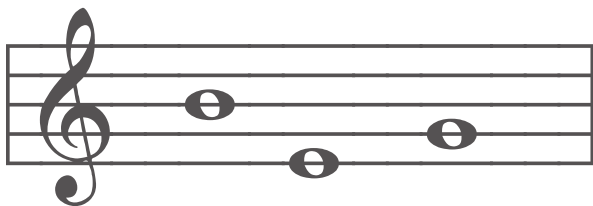

\_\_\_\_\_

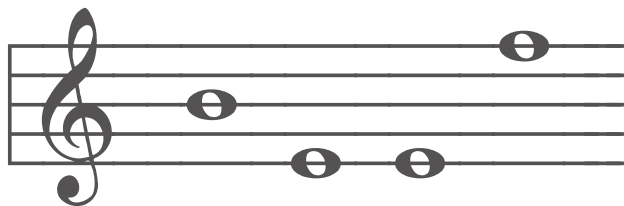

\_\_\_\_\_

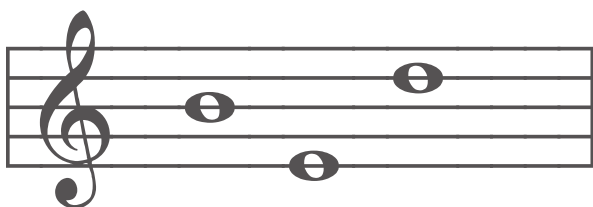

\_\_\_\_\_

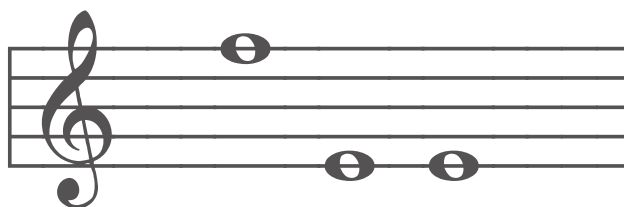

\_\_\_\_\_



# Copywork

O to grace how great a debtor  
Daily I'm constrained to be!  
Let Thy goodness, like a fetter,  
Bind my wandering heart to Thee.  
Prone to wander, Lord, I feel it,  
Prone to leave the God I love;  
Here's my heart, O take and seal it,  
Seal it for Thy courts above.

Handwriting practice lines consisting of solid top and bottom lines with a dashed midline, repeated 10 times.



COME, THOU FOUNT OF EVERY BLESSING  
*word search*

N P G L J P W G K F G E R L M O L A X X  
S J X V K S I D O F M L O H G J I S Z F  
Q Y Z W G Y A U L M N A B O Q Q M E P L  
G G I S N V N J E N W G E R K T D E V Z  
C E G E I T C Q G E I L R N A L B K R O  
X T I D S A X X V S U Q T S X Q F P T F  
S D N O S N I B O R V P T G R G G G E O  
T D U E E W O G Q T Y W P L N L Q O T G  
N Q Q C L S R S S T D Z T I W R M Z B N  
A L P H B U T N J I X A G P H Q W J B L  
T L W O L D R C Y B V N S W A Y H Q C O  
N Q R B U G G Y J G A T P B A L A Q G M  
E G K U F C S M C H Z U I E X N B Q Z U  
P P R X I W N F C F D B R B W Q D Y B E  
E G R A C E H N K K T R I K E T D E Y X  
R V K T R E U M M T G G T H V X T I R B  
L P D P E X S M J S U M E G R O T B E D  
J G Y G M T K S W P K U M R J P H F Q H  
Q P G Y M G N J R I J V N I T W P Z R A  
R Q M H K G U Z Q R G P K X U E O H Y V

WANDER  
UNCHANGING  
FOUNT  
SEEK

DEBTOR  
SPIRIT  
DAVID  
ROBINSON

ROBERT  
GRACE  
REPENTANT  
MERCIFUL BLESSING

# Extension Activities



Research the Philistines and write 3-5 paragraphs about who they were.



Learn about George Whitefield. Write a letter to someone in your family telling them some of the things you think they would find interesting.



Draw a timeline of King David's life.



Draw a fountain and illustrate the many blessings in your life as they overflow from the fountain.



Choose and write a word from the lesson, then write a synonym and antonym.





# JESUS PAID IT ALL

*the story*

Has your mind ever wandered during a Sunday service at church? Maybe you began thinking about a person nearby who caught your eye or plans you had later that day. Sometimes it can be hard to keep your focus. That's what happened to Elvina Hall one Sunday morning in 1865 at Monument Street Methodist Church in Baltimore. Rev. George Schrick was praying a lengthy prayer, and up in the choir loft, Elvina Hall's mind was wandering.

But unlike many people who begin thinking about things outside of church, Elvina was still very much focused on God. As the prayer lingered, her mind wandered to the mercy and grace of the cross, and the words to a poem began flowing in her grateful heart. Desperate to get them down, she grabbed her hymnal and scribbled these words on the front flap.

165 Jesus Paid It All  
*Elvina M. Hall, 1820-1889* *John T. Grape, 1835-1915*

1 I hear the Sav-ior say, Thy strength in-deed is small;  
2 Lord, now in-deed I find Thy power, and thine a-lone  
3 For noth-ing good have I, Where-by thy grace to claim,-  
4 Then down be-neath the cross I'll lay my sin-sick soul;  
5 And when be-fore the throne I stand, in him com-plete,

Child of weak-ness, watch and pray, Find in me thine all in all.  
Can change the lep-er's spots, And melt the heart of stone.  
I'll wash my gar-ments white in the blood of Cal-vary's Lamb.  
For naught have I to bring,- Thy grace must make me whole.  
I'll lay my tro-phies down,- All down at Je-sus' feet.

REFRAIN  
Je-sus paid it all, All to him I owe;

Sin had left a crim-son stain, He washed it white as snow.

*I hear my Savior say, Thy strength indeed is small,  
Thou hast naught My debt to pay, Find in Me thy all in all.*

*Yea, nothing good have I, Whereby Thy grace to claim;  
I'll wash my garments white, In the blood of Calvary's Lamb.*

*And now complete in Him, My robe His righteousness,  
Close sheltered 'neath His side, I am divinely blest,*

*When from my dying bed, My ransomed soul shall rise,  
Jesus paid it all, Shall rend the vaulted skies.*

When the sermon was over, she handed the poem to her pastor who immediately saw the beauty in what God had orchestrated. Just days before, the church organist, John T. Grape, had written a new tune and these words were the perfect fit.

This inspiring story shows us how God uses all of His people to accomplish His glory. Even though her mind was wandering from the prayer, Elvina Hall was focused on God and cherished the truths she wrote down that day. Her faithfulness and courage to share became a hymn Christians have cherished for generations.

# Hymn Study Notes

NAME OF THE HYMN

---

WRITTEN BY

---

YEAR & LANGUAGE THE HYMN WAS WRITTEN

---

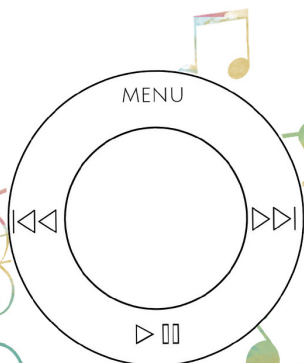

FACTS ABOUT THE AUTHOR



---



---



---



---



---



---

TELL ABOUT THE STORY BEHIND THE HYMN

---

---

---

---

---

---

---



# Bible LESSON

As we begin to study the Bible lesson today, let's talk a little bit about getting distracted in the service at church. Has this ever happened to you? \_\_\_\_\_

I'll be honest, it happens to everyone. People, things, and upcoming events distract us from focusing on God both in and out of church. We shouldn't feel bad about this; instead we should work to get rid of the distractions so we can focus on God! One way I do this is to take notes, but it might be different for someone else. Take a minute and talk with your parents about practical things you can do in your church to stay focused. Write them below.

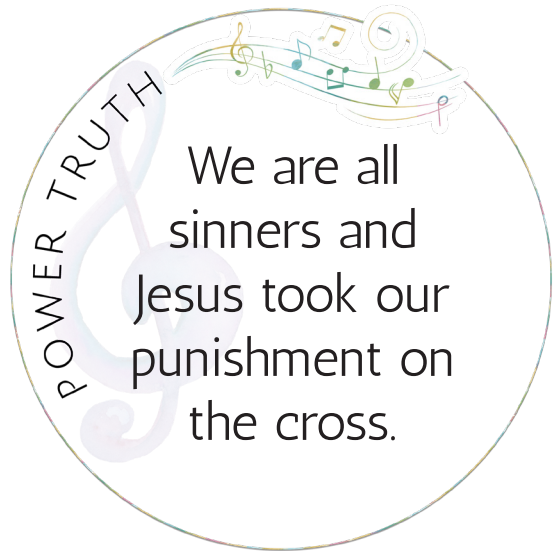

---

---

---

Elvina Hall might have been distracted from the service, but she was definitely focused on God. In her mind was the scene of mercy and grace. The scene where our Savior died for our sins. Read John 3:16. What does this mean to you?

---

---

---

Sometimes people who became Christians as children fall into a dangerous trap of not understanding that they were sinners just like everyone else. When this happens, they may not understand the beauty of what Jesus did for us.

Are you a sinner? Quote Scripture below to defend your answer. (Look back in this study if you need to or ask your parents for help.)

---

---

---



What sins have you committed? The truth is, you (and I) have committed more sins than we even know, and far more than we can count. Be honest with yourself and look at this list. Have you ever...

- |   |                              |                             |
|---|------------------------------|-----------------------------|
| Disobeyed your parents  | <input type="checkbox"/> YES | <input type="checkbox"/> NO |
| Said something that wasn't 100% true                              | <input type="checkbox"/> YES | <input type="checkbox"/> NO |
| Hid something so no one would know                                | <input type="checkbox"/> YES | <input type="checkbox"/> NO |
| Gotten angry with someone   | <input type="checkbox"/> YES | <input type="checkbox"/> NO |
| Said a bad word or taken the Lord's name in vain                  | <input type="checkbox"/> YES | <input type="checkbox"/> NO |
| Wanted something someone else had                                 | <input type="checkbox"/> YES | <input type="checkbox"/> NO |
| Taken something that wasn't yours                                 | <input type="checkbox"/> YES | <input type="checkbox"/> NO |
| Copied someone's paper  | <input type="checkbox"/> YES | <input type="checkbox"/> NO |
| Said something unkind   | <input type="checkbox"/> YES | <input type="checkbox"/> NO |
| Been impatient  | <input type="checkbox"/> YES | <input type="checkbox"/> NO |
| Refused to forgive someone  | <input type="checkbox"/> YES | <input type="checkbox"/> NO |
| Physically hurt someone (hit, punched, pinched, bit, pulled hair) | <input type="checkbox"/> YES | <input type="checkbox"/> NO |
| Preferred to do something else instead of church                  | <input type="checkbox"/> YES | <input type="checkbox"/> NO |
| Desired something more than God                                   | <input type="checkbox"/> YES | <input type="checkbox"/> NO |

The list goes on and on. The Bible says we are sinners, and we are indeed helpless in our sinful state. Let's end today by writing a prayer to God, thanking Him for sending His Son to pay our debt of sin on the cross.

---

---

---

---

---

---

---





# Music THEORY

Decode the secret words by writing the letter name of each note.

- Practice holding the tin whistle properly
- Practice making loud and soft sounds
- Play the D scale
- Play the hymn

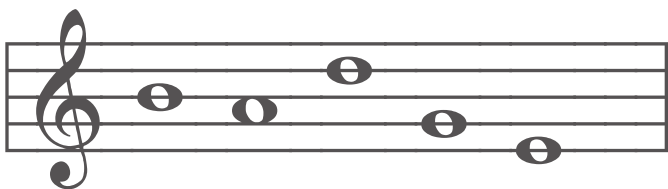

\_\_\_\_\_

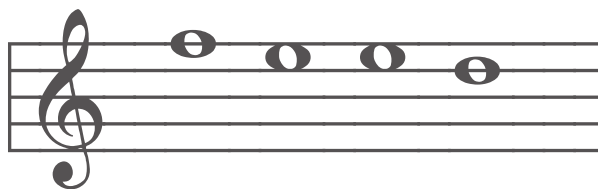

\_\_\_\_\_

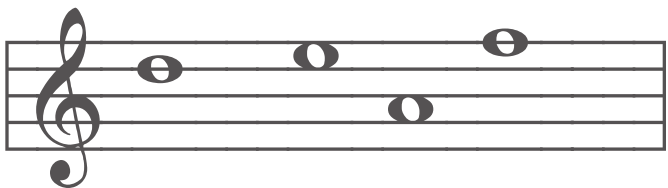

\_\_\_\_\_

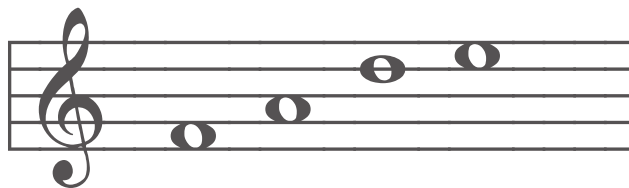

\_\_\_\_\_

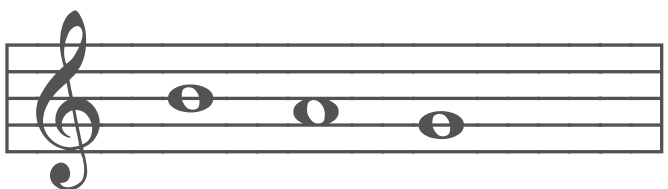

\_\_\_\_\_

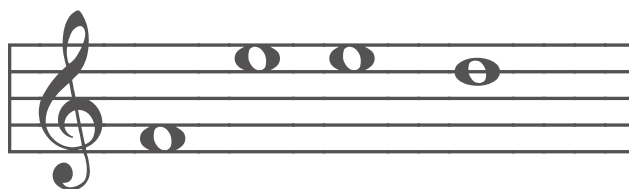

\_\_\_\_\_

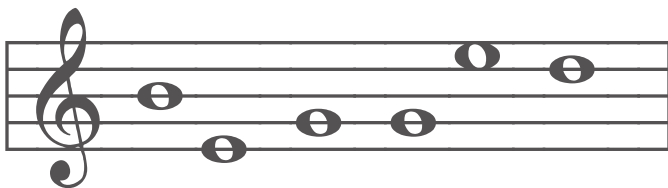

\_\_\_\_\_

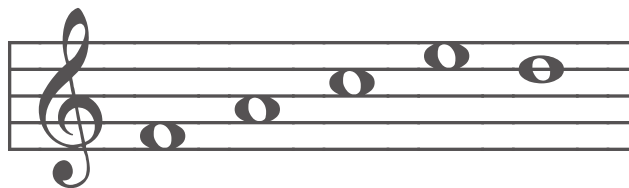

\_\_\_\_\_



# Copywork

I hear the Savior say,  
"Thy strength indeed is small;  
Child of weakness, watch and pray,  
Find in Me thine all in all."  
Jesus paid it all,  
All to Him I owe;  
Sin had left a crimson stain,  
He washed it white as snow.

Handwriting practice lines consisting of multiple sets of solid top and bottom lines with a dashed midline.

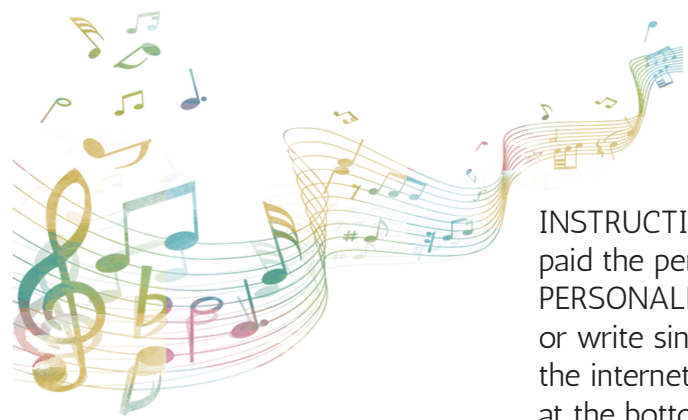

# JESUS PAID IT ALL

INSTRUCTIONS: Our sins were nailed to the cross with Jesus as He paid the penalty with death. On the middle cross, draw or write sins you PERSONALLY have committed. On the crosses to the left and right, draw or write sins you see in the world around you. Print a picture of Jesus off the internet and glue it on top of this page. Then write: "Jesus PAID it all" at the bottom. When you finish, pray and ask God's forgiveness for all of this.

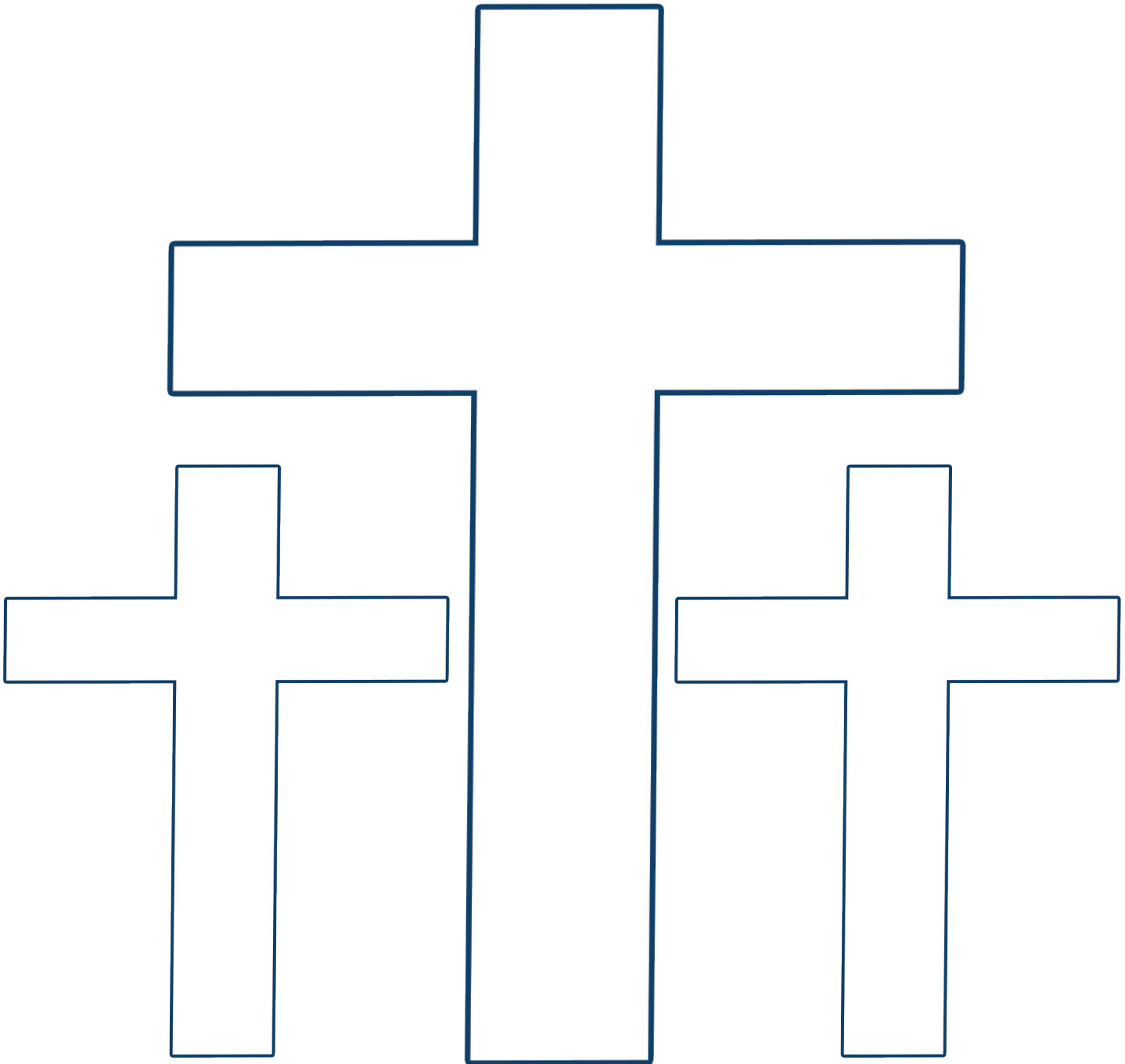

# Extension Activities



Go through the story of Jesus' death starting in Luke 22-24 and draw a timeline of events.



Jesus suffered an awful death so that we would be blessed with forgiveness of our sins. Today, do something you hate doing so that someone else will be blessed. (Maybe clean the toilets, wash dishes, clean out the trash cans.) Don't forget to do it with a happy heart!



Write a thank you note to Jesus thanking Him for paying the debt of your sins. Be specific in your note.



Write a letter to an unsaved relative or friend sharing how Jesus forgave you of your sins. Ask your parents to help you decide if now is the right time to send it.



Research Baltimore in 1865 and write 5 facts about life and culture at that time.





## AT CALVARY *the story*

William Newell was a no-good rebel who spent his teenage years causing trouble. But his broken-hearted father loved him dearly and felt desperate to help. He wrote a letter to Dr. R. A. Torrey, president of the Moody Bible Institute of Chicago, begging him to accept his prodigal son William as a student.

While Dr. Torrey sympathized with the man, he informed him that Moody was a Bible school, not a reformatory. But the persistent father wrote back, doubling his fee, and Dr. Torrey finally agreed.

At first, Dr. Torrey thought the arrangement was hopeless. William had some very big problems, and seemed torn apart by turbulence. But, he kept the rules and was even more attentive to Dr. Torrey than he appeared, so he was able to remain a student.

In the life of William R. Newell, love, mercy, and persistence paid off. He not only turned his life around, he began studying for the ministry.

In 1895, William decided to put his testimony into verse form. A few weeks later, he was walking to class when suddenly the words came to him. He stopped dead in his tracks and scribbled the words down. Rushing on to the class, he happened to run into Dr. Daniel Towner, the music director. He handed him the verses and suggested he use them as a hymn for the students.

Later, the music director retold how the entire hymn was complete before William had even gotten out of class. "Bill," said Dr. Towner, "I was so taken with the poem you gave me that I went immediately to my studio and composed a tune. I feel that it could be the best that either of us will ever write in our lifetime." The two sang it together, and it was published shortly afterwards.

Bill became a well-known Bible teacher and a beloved professor at Moody Bible Institute. He said that if he had not gone through trouble in his life, he might never have understood the importance of Calvary's grace.



*Mercy there was great, and grace was free;  
Pardon there was multiplied to me;  
There my burdened soul found liberty at Calvary.*

# Hymn Study Notes

NAME OF THE HYMN

---

WRITTEN BY

---

YEAR & LANGUAGE THE HYMN WAS WRITTEN

---

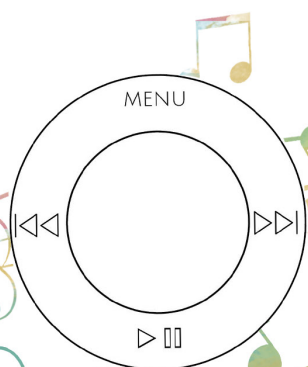

FACTS ABOUT THE AUTHOR



---



---



---



---



---



---

TELL ABOUT THE STORY BEHIND THE HYMN

---

---

---

---

---

---

---



# Bible LESSON

Read the story of Christ's crucifixion in Luke 23:32 - 49. As you read, use the crosses below to note the facts of the story.

+

\_\_\_\_\_

+

\_\_\_\_\_

+

\_\_\_\_\_

+

\_\_\_\_\_

+

\_\_\_\_\_

+

\_\_\_\_\_

+

\_\_\_\_\_

+

\_\_\_\_\_

Luke 23:34 is perhaps one of the most meaningful verses to me. While dying on the cross because of our sins, Jesus asked God to forgive the people killing Him. This is such incredible grace, isn't it? How does that make you feel?



Large empty rectangular area with a dashed border for writing.



The hymn writer, William Newell, knew personally the change in his life that Jesus gave him through Calvary. He also knew the love of a father who didn't give up on him, which reminds me of another story in the Bible.

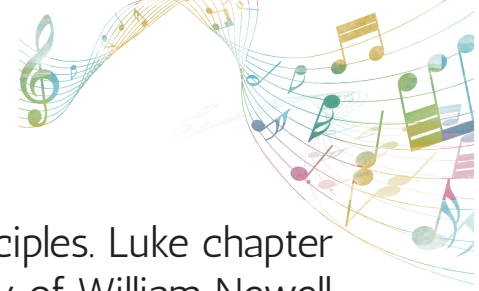

It was a parable Jesus shared while He was teaching the disciples. Luke chapter 15 shares the story of a son and a father, much like the story of William Newell. The ungrateful son took his inheritance and left his family to find a "better life."

Did he find that better life? (see Luke 15:13-16)

---

---

Broken, ashamed, and poor, the son decided to go home. He hoped his father would give him a job. But his father had a much different response. What did he do? (see Luke 15:20-24)

---

---

---

This is one of the most beautiful parables in the Bible, as it demonstrates the kind of love God has for us. Even though we wander, even though we sin, even when we make all the wrong choices, God still loves us. And when we come home to Him, He RUNS to us in celebration.



End today by writing a prayer, thanking God for the truths you learned today. Confess to Him the sins that you are guilty of, knowing He celebrates and loves you dearly.

---

---

---





- Practice holding the tin whistle properly
- Practice making loud and soft sounds
- Play the D scale
- Play the hymn

Write in the missing letters for each note in the D Scale.

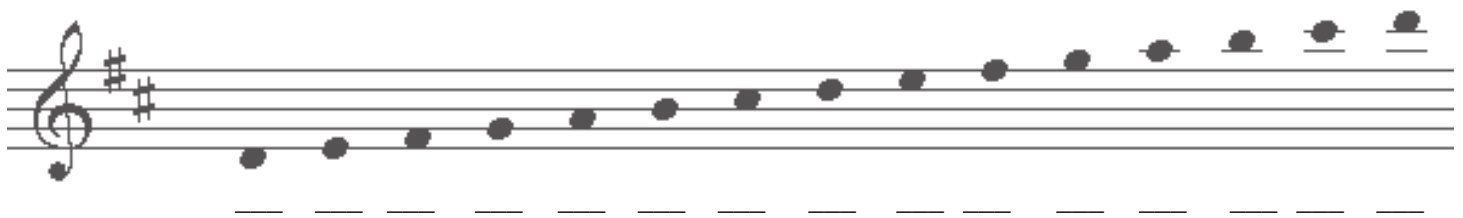

Draw the notes for the D scale and label them below.

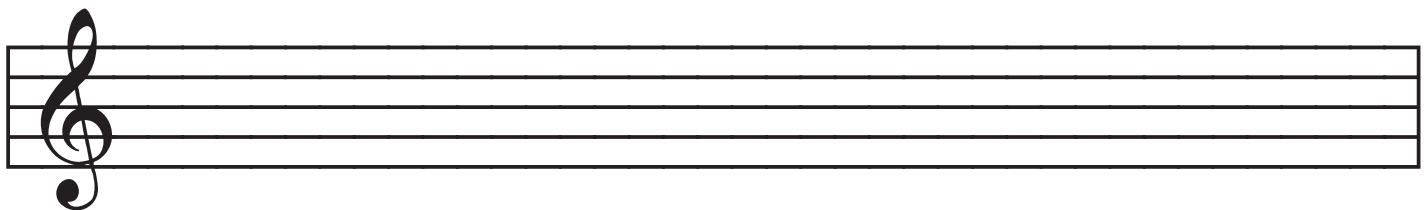
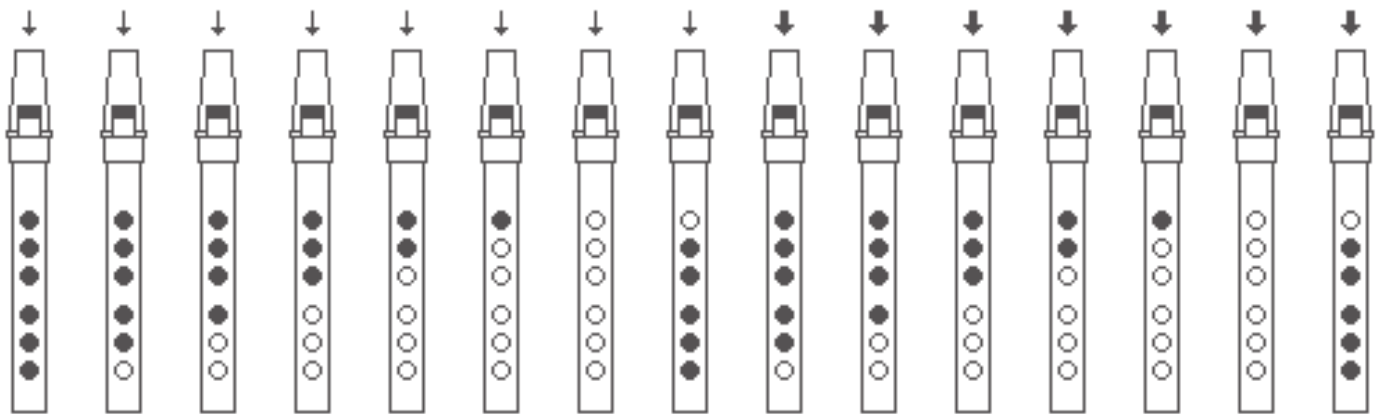



# Copywork

Years I spent in vanity and pride,  
Caring not my Lord was crucified,  
Knowing not it was for me He died  
On Calvary.

Mercy there was great, and grace was free;  
Pardon there was multiplied to me;  
There my burdened soul found liberty  
At Calvary.

Handwriting practice lines consisting of solid top and bottom lines with a dashed midline, repeated 10 times.



# AT CALVARY *crossword*

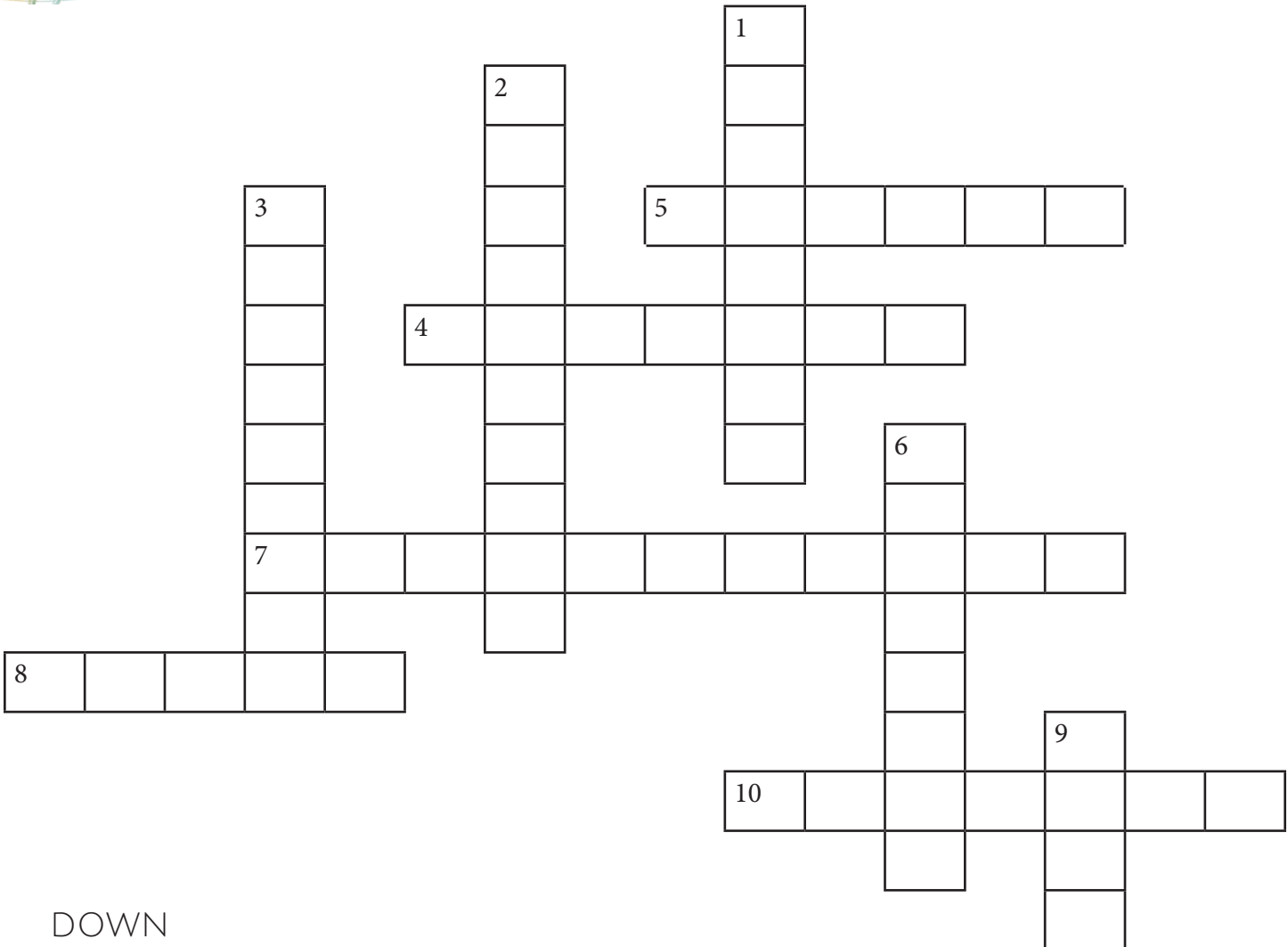

## DOWN





1. Who didn't give up on a rebellious teenage William?
2. From the song "Pardon there was \_\_\_\_\_ to me"
3. From the song "Caring not my Lord was \_\_\_\_\_"
6. What did William eventually start studying for?
9. Luke 23:38b "This is the \_\_\_\_\_ of the Jews"

## ACROSS

4. From the song "there my burdened soul found \_\_\_\_\_"
5. Luke 23:46 "Into thy hands I \_\_\_\_\_ my spirit"
7. What did the ungrateful son in Luke 15 take when he left his family?
8. What institute did William attend?
10. What did Jesus ask God to do for his persecutors?

# Extension Activities



 <p>Research Moody Bible Institute, write a report of what you learn.</p>	 <p>Imagine you were a news reporter at the Crucifixion. Write an eyewitness report of what you think the people would have been saying and doing.</p>
 <p>Write an acrostic for the words AT CALVARY using attributes of God.</p>	 <p>Jesus was wrongly accused. Make a card or write a note to someone that you have accused, hurt, or made fun of, apologizing for your unkind behavior.</p>
 <p>Choose a verb from the hymn story and find 3 words that rhyme with it.</p>	



# CHRIST THE LORD IS RISEN TODAY

*the story*

Although John and Charles Wesley were loved by many, they also found themselves hated by Anglican ministers who shunned their fiery preaching. Because of this, many pulpits were closed to their preaching.

The Wesley brothers and George Whitefield were good friends from Oxford. George found himself facing the same trials, so he decided to preach out in the open air. He asked Charles to go with him to preach outside, near Blackheart, London. It was there that Charles got a vision for preaching to the multitudes.

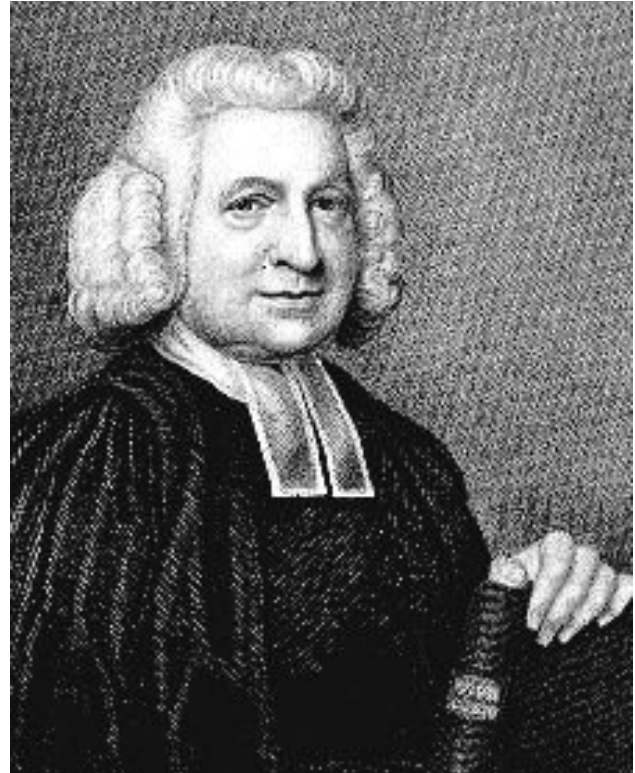

His first attempt was made outside of London. "Franklyn, a farmer, invited me to preach in his field," he wrote, "I did so to about five thousand. I returned to the house rejoicing." Soon he was preaching to thousands. "My load was gone, and all my doubts and scruples. God shone upon my path; and I knew this was His will concerning me."

Although Charles no longer preaches in person, his words still move the hearts of many through his hymns. One of his most exuberant songs is one he called "Hymn for Easter Day," published in 1739. This hymn was originally published as a Latin poem in the 14th century. John and Charles Wesley modified a translation of the hymn and published eleven stanzas of magnificent praise. Today we only sing a few stanzas and have an added chorus of "alleluias."

Today, this hymn is the most commonly sung hymn around the world in celebration of Easter and our risen Lord.

# Hymn Study Notes

NAME OF THE HYMN

---

WRITTEN BY

---

YEAR & LANGUAGE THE HYMN WAS WRITTEN

---

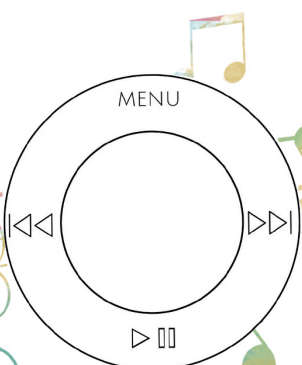

FACTS ABOUT THE AUTHOR



---



---



---



---



---



---

TELL ABOUT THE STORY BEHIND THE HYMN

---

---

---

---

---

---

---



# Bible LESSON

After Jesus died, the whole earth was dark. The sins of the world had been paid in the most gruesome of ways. Can you imagine how the disciples must have felt? Jesus told them He would die and that He would rise again, but they didn't understand that. In fact, no one really did.

Let's read the account of the women who first discovered the good news. Read Matthew 28:1-10. Who are the two women mentioned here?

---

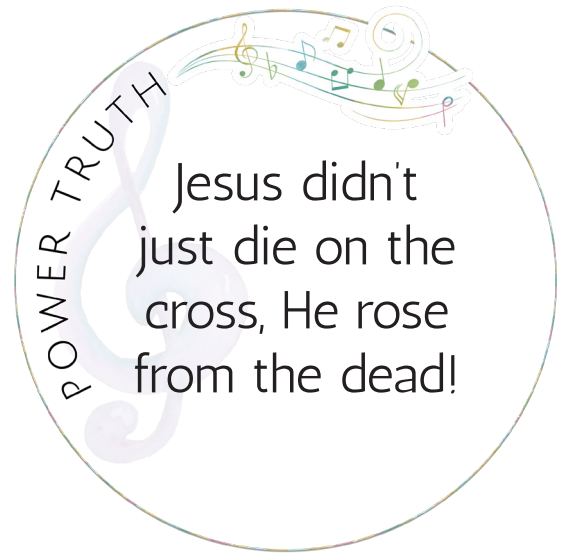

Write or draw the scene they found when they got to the tomb.



The first part of verse 6 is one of the most famous verses in the Bible, especially at Easter. Write the first sentence on the line.

---

The Bible says the women were afraid. Once they heard the news and began to understand it, how do you think they felt? How would you have felt if you had been there?

---

---



We find an account of this story again in Luke 24:6 - 12. This time we learn more about what happened. What did the angel say had happened, in verses 6 - 7?

---

---

As soon as they heard this news, what did the women do? (See verses 8 - 10)

---

How did the disciples take this news in verse 11?

---

It is definitely hard to understand things sometimes. In fact, we can't be too hard on the disciples, as it's likely we would have been skeptical, too. But don't worry. Jesus knew they would do this and He still loved them enough to make sure they heard the truth personally.

Read Luke 24:36 - 39. Describe the scene when Jesus appeared to the disciples.

---

---

---

Now read Luke 24:44 - 45. What else did Jesus do for them? (Look closely at verse 45.)

---

End today by writing a prayer, thanking Him for dying for your sins and the miracle of rising from the dead. Thank Him for loving us enough to show Himself to us over and over again until we believe.

---

---

---

---





# Music THEORY

- Practice holding the tin whistle properly
- Practice making loud and soft sounds
- Play the D scale
- Play the hymn

*Time Signatures* are placed at the beginning of a piece of music. They are made up of 2 numbers.

In  $\frac{4}{4}$  time there are four beats per measure. A quarter gets one beat.

←The top number shows the number of beats per measure  
←The bottom number shows what kind of note will get one beat

Clap the rhythm of the notes while counting the beats aloud.

1 2 3 4    1 2 3 4    1 2 3 4    1 2 3 4    1 2 3 4    1 2 3 4

Write a  $\frac{4}{4}$  time signature after the clef sign. Write in the beat below the notes indicated. Then clap the rhythm while counting the beats out loud.

— — — —    — — — —    — — — —    — — — —

←In  $\frac{3}{4}$  time, there are three beats in each measure  
←The quarter note gets one beat

Practice the following rhythm by tapping the rhythm while counting the beats aloud.

1 2 3    1 2 3    1 2 3    1 2 3    1 2 3    1 2 3

Write a  $\frac{3}{4}$  time signature after the treble sign. Write in the counts on the lines below the notes and then tap the rhythm while counting the beats aloud.

— — —    — — —    — — —    — — —    — — —



# Copywork

Christ the Lord is ris'n today, Alleluia!  
Sons of men and angels say, Alleluia!  
Raise your joys and triumphs high, Alleluia!  
Sing, ye heav'ns, and earth, reply, Alleluia!  
Lives again our glorious King, Alleluia!  
Where, O death, is now thy sting? Alleluia!  
Once He died our souls to save, Alleluia!  
Where thy victory, O grave? Alleluia!

Handwriting practice lines consisting of solid top and bottom lines with a dashed midline, repeated ten times.



## Word Scramble

How many different words can you make from the letters in the phrase "Christ's Resurrection"? Write them on the lines below. Hint: you can write the letters on paper and cut them out to make titles. Then move them around to make new words.

# CHRIST'S RESURRECTION

_____	_____
_____	_____
_____	_____
_____	_____
_____	_____
_____	_____
_____	_____
_____	_____
_____	_____
_____	_____
_____	_____
_____	_____
_____	_____
_____	_____
_____	_____
_____	_____
_____	_____
_____	_____
_____	_____
_____	_____
_____	_____
_____	_____
_____	_____

# Extension Activities



Write an account of Jesus' death and resurrection like you are one of these people: Mary, Peter, Pilate, Judas, the Centurion, Pharisees.



Joseph of Arimathea gave up something very important to his family so that Jesus would have a proper tomb. Give up something important today so that someone else will have something special.



Make resurrection cookies (find a recipe on Pinterest) to tell the story of Jesus.



The news of resurrection is too good not to share. Create a card telling the story and give it to another child you see this week or sometime soon.



Draw a cartoon showing the different responses of the people who saw Jesus after He rose from the dead.





## HE LIVES *the story*

"Why should I worship a dead Jew?" This question, as well as a terrible sermon, were the inspiration of "He Lives."

Alfred Henry Ackley was born in 1887 in the beautiful state of Pennsylvania. Because he showed great potential as a child, he was given private tutoring by his father, a musician himself. He was later sent to New York City to study music and eventually London to the Royal Academy of Music. He was ordained into the Presbyterian ministry in 1914. After pastoring in his home state of Pennsylvania, he was called to a church in California.

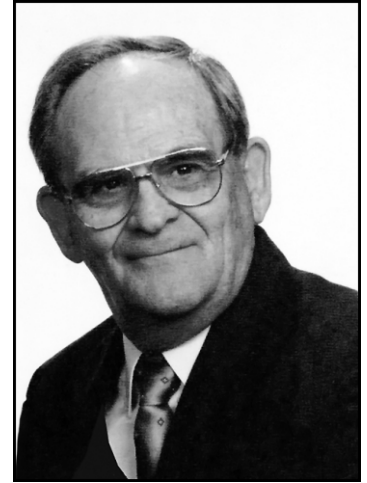

It was there in 1932 where Alfred met a Jewish man. He witnessed to the man who refused to listen to his words. "Why should I worship a dead Jew?"

The man's question remained in his mind as he prepared his Easter Sunday sermon. As he prepared for the day, he flipped on his radio. He was astonished when the voice he heard was the voice of a famous liberal preacher in New York: "Good morning - It's Easter! You know, folks, it really doesn't make a difference to me if Christ be risen or not. As far as I'm concerned, His body could be dust in some Palestinian tomb. The main thing is, His truth goes marching on!"

Alfred wanted to fling the radio across the room. "It's a lie!" he exclaimed. Alfred preached that morning with much vigor on the reality of Christ's resurrection, and did the same that evening. But later that night, the question of the man and the preacher lingered in his mind.

"Listen here, Alfred Ackley," his wife said at last. "It's time you did that which you can do best. Why don't you write a song about it and then maybe you'll feel better?"

That very night in 1933, Alfred went to his study, opened his Bible, and reread the resurrection account. Thrilled, he quickly began writing the words to "He Lives" and tapping out a tune on his piano, never imagining that it would become one of the most well-known Easter hymns.

# Hymn Study Notes

NAME OF THE HYMN

---

WRITTEN BY

---

YEAR & LANGUAGE THE HYMN WAS WRITTEN

---

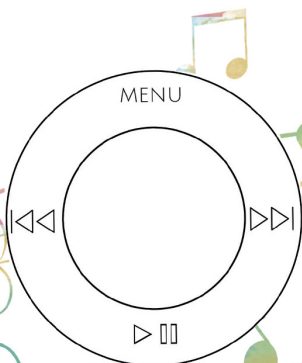

FACTS ABOUT THE AUTHOR



---



---



---



---



---



---

TELL ABOUT THE STORY BEHIND THE HYMN

---

---

---

---

---

---

---



# Bible LESSON

The question that fired up Alfred Ackley is one we as Christians should also be passionate about. If Jesus wasn't raised from the dead, the entire Bible is false. Let's consider these facts.

Look up 1 Corinthians 15:14. If Christ wasn't raised from the dead what two things are vain or useless?

1. \_\_\_\_\_

2. \_\_\_\_\_

Read Proverbs 30:5. What does it say about God's Word?

\_\_\_\_\_

What warning does Proverbs 30:6 give us?

\_\_\_\_\_

We can't add to or take away from the Word of God. All of His words are true. Christians today like to listen to some parts, but not listen to others.

Let's read 2 Timothy 3:16 - 17. First, notice the word before Scripture. What is it?

\_\_\_\_\_

It's really important that we don't miss this three-letter word. ALL means every single word. Not some words. Not a few words. Not most of the words. All means that every single word in the Bible was God-breathed.

This passage also gives us four things the Word of God is used for. List them below.

 \_\_\_\_\_

 \_\_\_\_\_

 \_\_\_\_\_

 \_\_\_\_\_

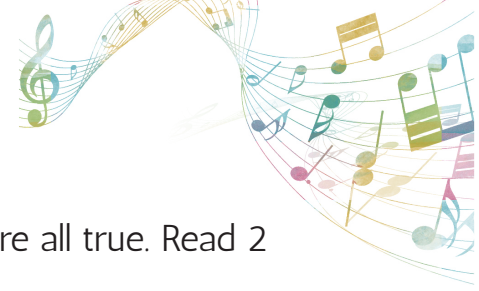

Lastly, I think it's important to note that the words of Jesus himself are all true. Read 2 Corinthians 5:21. What does it say about Jesus?

---

---

If Jesus knew no sin, that means everything He said was true because lying is a sin. So, we can trust everything He had to say. Let's read Mark 8:31 - 33. What did Jesus say would happen to Him? Did this include resurrection?

---

---

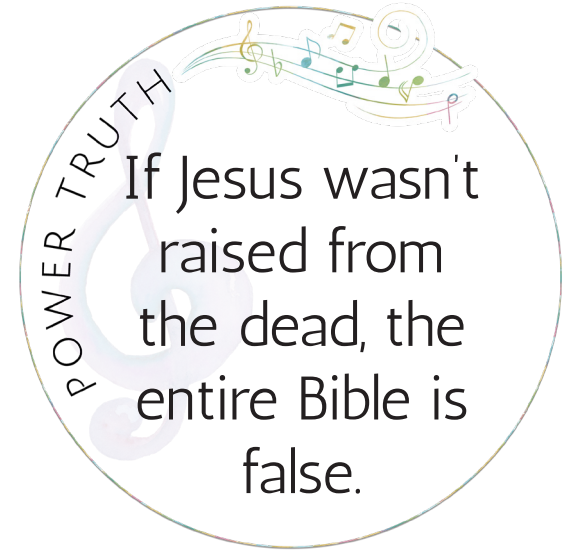

Alfred Ackley was right. It's a big deal to say it doesn't matter if Jesus was raised from the dead. If it didn't happen, that means our faith is useless or in vain. And it means Jesus was nothing but a lying sinner.

As Christians it's very important to know and understand what we believe so we don't fall into the same trap as that radio pastor did. Today there are many false teachers out there, preaching things that don't line up with the Bible. Don't listen to them!

End today by writing a prayer to God, telling Him exactly what you believe about the resurrection and why it's true!

---

---

---

---

---

---

---

---

---

---





# Music THEORY

- Practice holding the tin whistle properly
- Practice making loud and soft sounds
- Play the D scale
- Play the hymn

Create your own music by filling in each of the bars with 4 counts. You can use whole notes, half notes, quarter notes, eighth notes, and any rests you wish. Once you have created it, practice clapping the rhythm.

Six blank musical staves are arranged vertically. Each staff begins with a treble clef and a 4/4 time signature. The staves are empty, intended for the student to write their own musical notation. Each staff ends with a double bar line.



# Copywork

He lives, He lives, Christ Jesus lives today!  
He walks with me and talks with me along life's narrow way.  
He lives, He lives, salvation to impart!  
You ask me how I know He lives?  
He lives within my heart.

Handwriting practice lines consisting of solid top and bottom lines with a dashed midline, repeated 10 times.



# ROMANS ROAD *to salvation*

Use the Bible to fill in the blanks. Then practice the verses so you can share the good news with someone who is lost.

Romans 3:10

As it is written: "None is righteous, no, \_\_\_\_\_."

Romans 3:23

For \_\_\_\_\_ have sinned and fall short of the glory of God.

Romans 5:12

Therefore, just as sin came into the world through \_\_\_\_\_, and death through sin, and so death spread to all men because all sinned—

Romans 6:23

For the wages of sin is \_\_\_\_\_, but the free gift of God is eternal life in Christ Jesus our Lord.



Romans 5:8

but God shows his love for us in that while we were still sinners, \_\_\_\_\_ died for us.

Romans 10:9 - 10

<sup>9</sup> because, if you confess with your mouth that Jesus is Lord and believe in your heart that God raised him from the dead, you will be \_\_\_\_\_<sup>10</sup> For with the heart one believes and is justified, and with the mouth one confesses and is saved.

Romans 10:13

For "\_\_\_\_\_ who calls on the name of the Lord will be saved."

# Extension Activities



Draw a Venn Diagram comparing the beliefs of Jews and Christians.



Mary and Mary Magdalene were coming to visit the grave of Jesus when they got the news. It can be very lonely when a loved one dies. Do you know a widow? Find out from your church about someone that you might visit. Take her a card or a special treat and spend time with him/her.



Learn (or practice) the Romans road so you will be ready to give an answer to anyone with questions about God. Then share it with someone and tell them about what HE has done for you!



The world is full of false teachers who are preaching lies. Learn about one of them and write down 2-3 lies they share along with the truth of the Bible to prove them wrong.



Draw a picture of the tomb and write words around it to describe all you've learned about Jesus' death and resurrection.





# IN THE GARDEN

*the story*

The art of meditating on Scripture takes great imagination. Instead of simply reading the passage, we must read it, close our eyes, and visualize the scene, perhaps even putting ourselves in the picture. That is exactly what the author of this hymn did.

C. Austin Miles was a pharmacist who also enjoyed writing hymns, and before long began editing hymnals and songbooks. He also became a popular music director at camp meetings, conventions, and churches. In his spare time, he enjoyed photography. It was in a quiet serene darkroom where he often sought time alone either to work on his photos, or to work on his devotional life. Here he could read his Bible in total privacy.



One evening in March 1912, while waiting for some film to develop, he opened his Bible to his favorite chapter, John 20. It was the story of the first Easter. Miles later said:

"As I read it that day, I seemed to be part of the scene.... My hands were resting on the Bible while I stared at the light blue wall. As the light faded, I seemed to be standing at the entrance of a garden, looking down a gently winding path, shaded by olive branches. A woman in white, with head bowed, hand clasping her throat as if to choke back her sobs, walked slowly into the shadows. It was Mary. As she came to the tomb, upon which she placed her hand, she bent over to look in and then hurried away. John, in flowing robe, appeared, looking at the tomb; then came Peter, who entered the tomb, followed slowly by John.

"As they departed, Mary reappeared, leaning her head upon her arm at the tomb. She wept. Turning herself, she saw Jesus standing; so did I. I knew it was He. She knelt before Him, with arms outstretched, and looking into His face, cried, 'Rabboni!'

"I awakened in full light, gripping my Bible, with muscles tense and nerves vibrating. Under the inspiration of this vision I wrote as quickly as the words would be formed, the poem exactly as it has since appeared. That same evening I wrote the music."

Austin Miles wrote several other popular hymns, but none as vividly beautiful as "In The Garden."

# Hymn Study Notes

NAME OF THE HYMN

---

WRITTEN BY

---

YEAR & LANGUAGE THE HYMN WAS WRITTEN

---

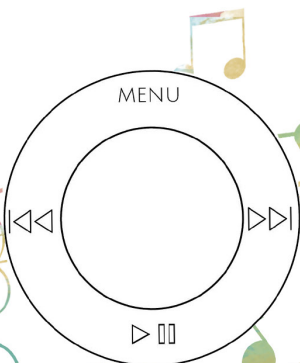

FACTS ABOUT THE AUTHOR



---



---



---



---



---



---

TELL ABOUT THE STORY BEHIND THE HYMN

---

---

---

---

---

---

---



# Bible LESSON

Austin Miles, author of "In the Garden," wrote the hymn after daydreaming about the scene of John 20. We read Mark's version of this story when we studied the resurrection. John gives us more details to enjoy.

Read John 20:11-18. Who are the people in this passage?

---

What is the problem?

---

---

Describe the scene where Mary realizes it's Jesus talking, using words or pictures.



Can you imagine being face to face with Jesus in the garden that day? What do you think you would have said?

---

---

---

The chorus of this hymn is my favorite. It reads:

*And He walks with me, and He talks with me,  
And He tells me I am His own;  
And the joy we share as we tarry there,  
None other has ever known.*

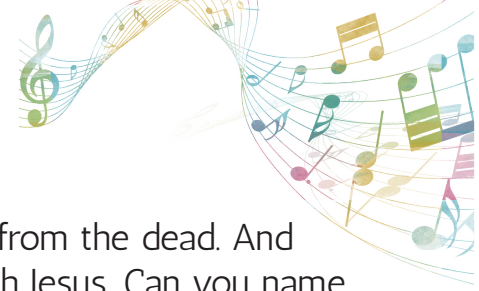

That's what happened in the garden for Mary after Jesus was raised from the dead. And that's what we can have, too. As Christians, we can walk and talk with Jesus. Can you name some ways we might do that?



\_\_\_\_\_



\_\_\_\_\_



\_\_\_\_\_



\_\_\_\_\_

Let's look at some verses that will give you a clear picture of what it looks like to walk and talk with God. Write what you learn beside each verse.

Psalm 119:105 \_\_\_\_\_

Micah 6:8 \_\_\_\_\_

Deut. 5:33 \_\_\_\_\_

James 4:8 \_\_\_\_\_

Col. 2:6 - 7 \_\_\_\_\_

Isaiah 30:21 \_\_\_\_\_

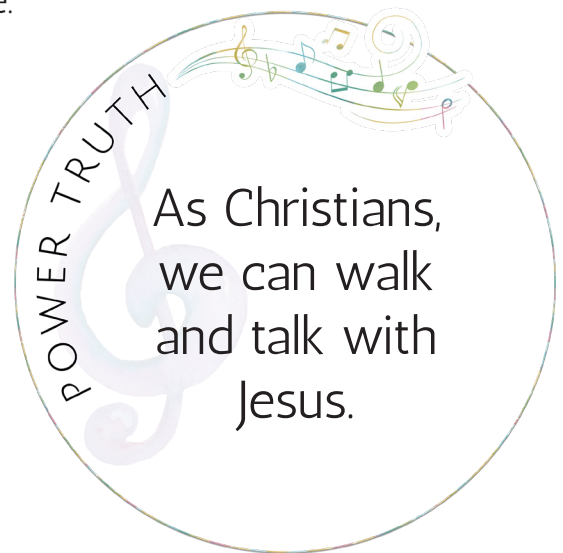

Which verse above is most meaningful to you?

\_\_\_\_\_

End today by praying and asking God to help you walk with Him. Use some of the words you learned from the verses above.

\_\_\_\_\_





\_\_\_\_\_

\_\_\_\_\_

\_\_\_\_\_





-  Practice holding the tin whistle properly
-  Practice making loud and soft sounds
-  Play the D scale
-  Play the hymn

FLAT SIGN (b) lowers the pitch of a note by a half step. On the keyboard of a piano, the black key to the left of the white key is a half step lower.

Try drawing the flats by tracing over the dotted lines. Then draw five more flats on the staff.

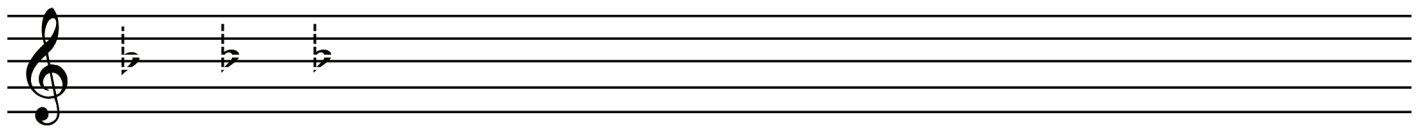

Draw a flat sign in front of each note. Then write the names of the notes indicated.

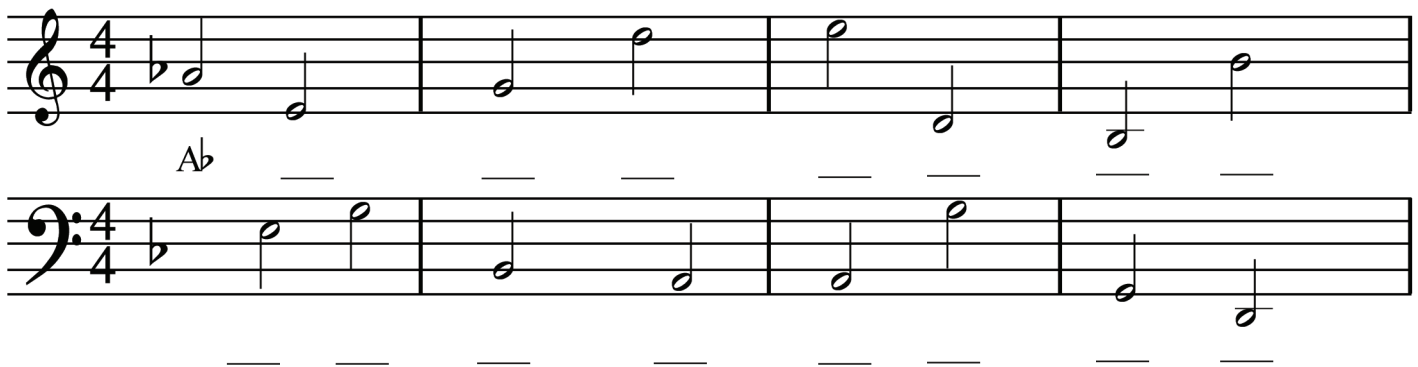

A SHARP sign (#) raises the pitch of a note by a half step. On the keyboard of a piano, the black key to the right of the white key is a half step higher and is called a sharp.

Try drawing sharps by tracing over the dotted lines. Then draw five more sharps on the staff.

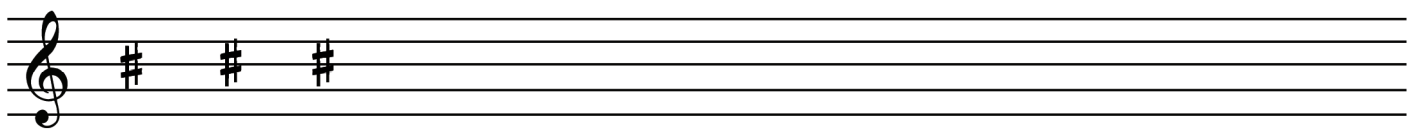

Draw a sharp sign in front of each note. Then write the names of the notes indicated.

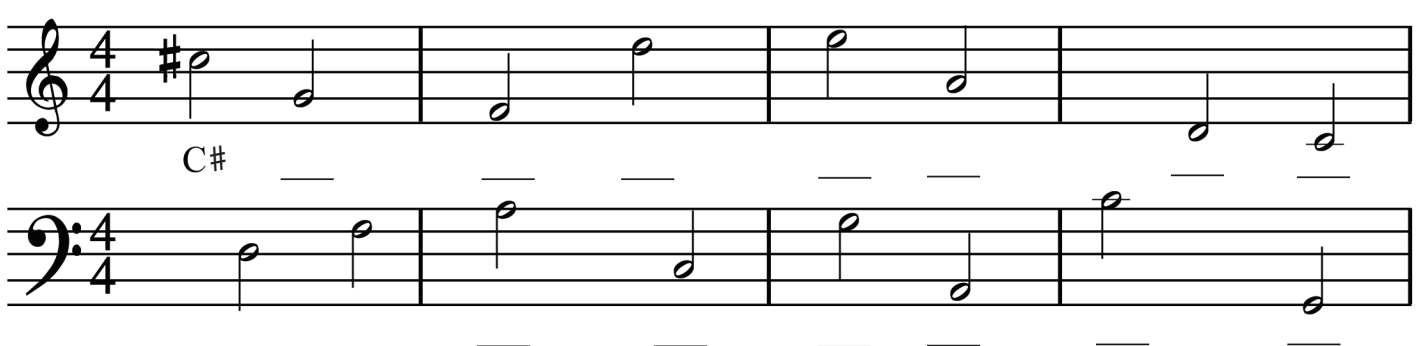



# Copywork

And He walks with me, and He talks with me,  
And He tells me I am His own;  
And the joy we share as we tarry there,  
None other has ever known.

Handwriting practice lines consisting of solid top and bottom lines with a dashed midline, repeated 10 times.



# IN THE GARDEN

Create a garden of love. Finish each flower by drawing it on the stems. Inside the flower, write ways you can show love to others.



# Extension Activities



Plant a flower or help weed the garden with your parents or neighbors.



Visualize yourself in Israel at the time of Jesus. Would you have been a follower of Christ or a Pharisee? Tell why you think you would have been on that side.



Research modern day Palestine and create a report showing your best findings.



Decorate a paper flower and add a verse about Jesus' resurrection. Give it to someone who might need to know this truth.



Learn to create a paper flower by searching with your parents on YouTube.





# TRUST AND OBEY

*the story*

Have you ever been to a revival, a tent meeting, or heard an evangelist preach? "Trust and Obey" was written one evening in 1887 during a revival meeting conducted by world-renowned evangelist D. L. Moody. Daniel Towner was among the many people in attendance that evening. A young man in the crowd stood up and offered his testimony. "I'm not quite sure—but I'm going to trust, and I'm going to obey," the man professed.

Daniel Towner jotted the inspirational words down and took them back to his pastor, John H. Sammis. Without hesitation, Reverend Sammis wrote a poem based on the words and passed it back to Daniel Towner.

Daniel was a beloved music teacher who came by his talent naturally. He grew up listening to some of the finest musicians and served as the worship leader of his church.

While working on the melody, Daniel became discouraged. He crumpled up what he had been working on and threw it in the trash can. Discovering it in the trash the next morning, his wife sang and played through the tune. She was deeply moved and encouraged her husband to work on it more. Thankfully he did, and the hymn became an inspiration to generations of Christians.

In 1893, Dr. Daniel Towner became head of the music department at Moody Bible Institute. (You might remember him from the story of "At Calvary.") There he trained hundreds of young people to lead worship and minister to the Lord through music. He wrote the melodies for many other beloved hymns such as "At Calvary" and "Grace Greater Than All Our Sins." He also compiled 14 hymnbooks and wrote several textbooks.



# Hymn Study Notes

NAME OF THE HYMN

---

WRITTEN BY

---

YEAR & LANGUAGE THE HYMN WAS WRITTEN

---

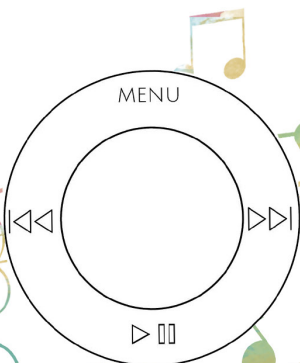

FACTS ABOUT THE AUTHOR



---



---



---



---



---



---

TELL ABOUT THE STORY BEHIND THE HYMN

---

---

---

---

---

---

---



# Bible LESSON

The beauty of this hymn is this simple formula of the Christian life: trust and obey. There truly is no other way! Let's read Proverbs 3:5-6. Draw what this verse is telling you to do.

A large rectangular area enclosed by a dashed blue line, intended for a drawing. It is decorated with musical notes and a treble clef in the top-left and bottom-right corners.

The benefits of trusting God are very clear in this verse. Now let's look at a verse that shows us the truth about obedience. Read John 14:15. Write the whole verse below.

---

This is a hard verse to face. If we truly love God, we will obey Him. What is the benefit of obedience? Read Deuteronomy 28:1-2 for the answer.

---

---

Those verses are such an encouragement. Obedience brings blessing. In fact, if you read on in that chapter there are 14 verses full of blessing!

Two things people really struggle with are WHEN we should trust and obey and HOW we should do it. Let's read over the verses of the hymn for some insight on this. Match the verse number with the different times when we must trust and obey God.



- Verse 1 following God's call for our life
- Verse 2 during the difficult times in life
- Verse 3 our daily walk in life
- Verse 4 our total submission

Was there a time in your life when you should have trusted and obeyed, but didn't? Write about it and tell what happened.

---



---



---



---



---







Was there a time in your life when you did trust and obey God? Write about that below. If you can't think of one, ask a parent or sibling and write their answer below.





---



---

Make a list of the things in your life you need to trust and obey God with. Once you've finished the list, take some time to pray and ask God to help you with each one.

-  \_\_\_\_\_
-  \_\_\_\_\_
-  \_\_\_\_\_
-  \_\_\_\_\_

-  \_\_\_\_\_
-  \_\_\_\_\_
-  \_\_\_\_\_
-  \_\_\_\_\_





- Practice holding the tin whistle properly
- Practice making loud and soft sounds
- Play the D scale
- Play the hymn

Label each instrument family in the orchestra.

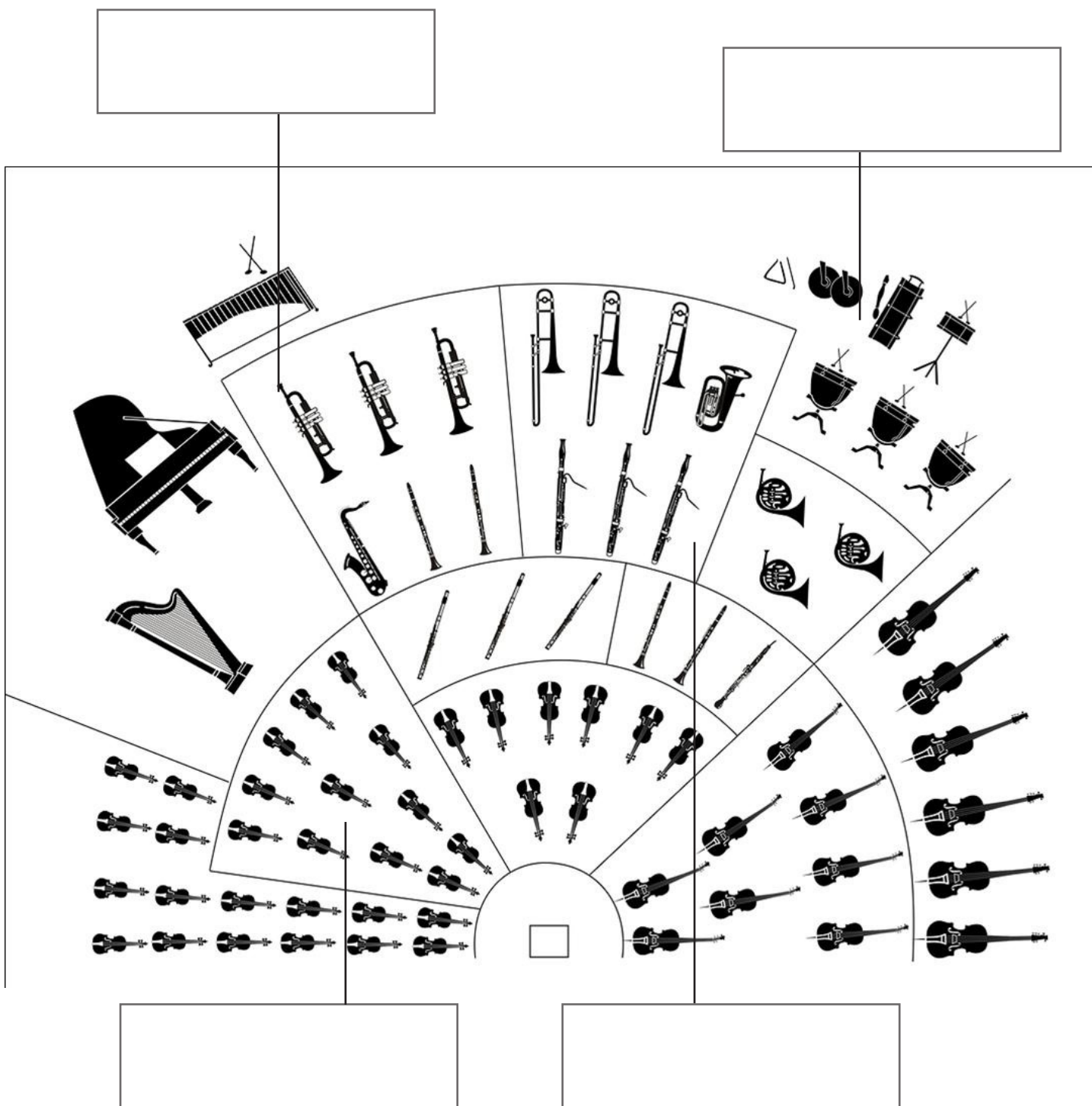



# Copywork

When we walk with the Lord in the light of His Word,  
What a glory He sheds on our way!  
While we do His good will, He abides with us still,  
And with all who will trust and obey.  
Trust and obey, for there's no other way  
To be happy in Jesus, but to trust and obey.

Handwriting practice lines consisting of multiple sets of solid top and bottom lines with a dashed midline.



# TRUST AND OBEY

Unscramble the words from the lesson

1. viraelv

---

2. naisucmi

---

3. dnotmoeeryu

---

4. enlida

---

5. osibsuisnm

---

6. orgyl

---

7. aidseb

---

8. deenobeci

---

9. sfllehpiwo

---

10. oyomd

---

11. rvrbpeos

---

12. topairnsini

---

13. utsrt

---

14. omsiytent

---

15. eenguntcaorme

---

## WORD BANK

inspiration abides revival encouragement Daniel musician  
glory Deuteronomy fellowship obedience Moody Proverbs  
trust testimony submission

# Extension Activities



Write or draw the order of events that happened in Daniel Towner's story.



Using note cards or small pieces of paper, draw pictures of people you can trust and should obey. Staple them together to make a book with Jesus first.



Research D.L. Moody and write 3 paragraphs about his ministry.



Have a parent go online and help you learn about the history of the Moody Bible Institute. Write or draw 5 things you learn.



Write a poem about being happy in Jesus.





# WHEN WE ALL GET TO HEAVEN

*the story*

If there is a common theme in the lives of the hymn writers we've studied, it's Romans 8:28. Over and over again we've seen God use situations that seemed hopeless and turn them into something good. Such is the case with the life of Eliza Edmunds Hewitt, author of "When We All Get to Heaven."

Born in Philadelphia, Eliza was well-educated and valedictorian of her class. She became a teacher in the public school system and devoted her life to helping others. Sadly, one of the students hit her with a piece of slate, causing an injury to her back. Eliza became bedridden for much of the rest of her life.

While in bed, she studied English literature and poetry. One day in 1898, she scribbled down these words while studying John 14:

*Sing the wondrous love of Jesus; sing his mercy and his grace.  
In the mansions bright and blessed he'll prepare for us a place.*

Some of her lines fell into the hands of Professor John R. Sweney, who wrote to her asking for more. Together they published many popular hymns, including "Singing I Go Along Life's Road," as well as "Will There Be Any Stars in My Crown?" "My Faith Has Found a Resting Place," "Sunshine in My Soul," "More About Jesus," and, of course, this hymn, "When We All Get to Heaven."

Despite spending much of her life in bed, Eliza became one of the most influential women hymn writers in the late 1800s and the early 1900s. She could have chosen to be angry and bitter at God or even at the student who harmed her. Instead, she forgave, and she trusted God to use her in any way possible. Because of her faithfulness, we can see God's glory through the hymns she wrote.

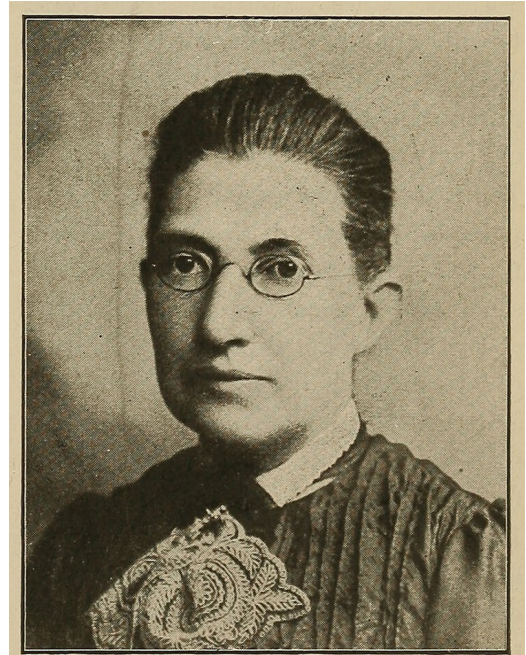

MISS E. E. HEWITT.

# Hymn Study Notes

NAME OF THE HYMN

---

WRITTEN BY

---

YEAR & LANGUAGE THE HYMN WAS WRITTEN

---

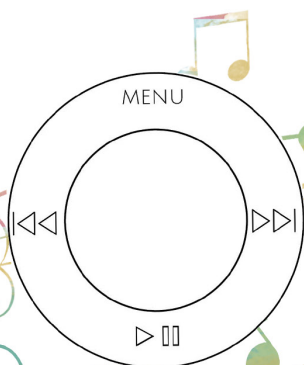

FACTS ABOUT THE AUTHOR



---



---



---



---



---



---

TELL ABOUT THE STORY BEHIND THE HYMN

---

---

---

---

---

---

---



# Bible LESSON

Read John 14:1 - 3. This conversation occurs in the upper room just hours before Jesus would be betrayed. He gives His disciples three specific things to do in verse 1. What are they?

1. \_\_\_\_\_

2. \_\_\_\_\_

3. \_\_\_\_\_

Next, He tells them what He is going to do in verses 2 - 3. In your own words, write some of the details Jesus shares.

---

---

Have you ever imagined what heaven will be like? Let's read Revelation 22:1 - 5. As you read, draw each element in the box below. Be as specific as possible.

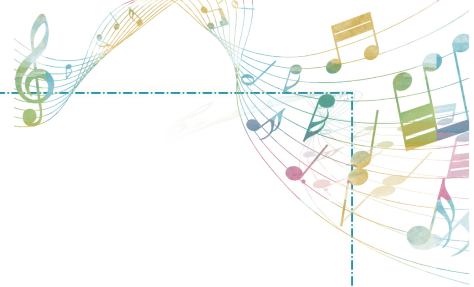

It's fun to imagine what it possibly could be like, but we need to remember the truth of 1 Corinthians 2:9.

Even in our wildest imagination \_\_\_\_\_

One thing I love the most about what the Bible says about heaven is found in Revelation 21:4. What does that verse say?

\_\_\_\_\_

What are you most looking forward to when you get to heaven?





\_\_\_\_\_  
\_\_\_\_\_

Are you sure you are going to heaven when you die? You can absolutely know for sure if you are saved. If you answered no, talk to your parents about this. If you answered yes, write how you know for sure and then share it with your parents.

\_\_\_\_\_  
\_\_\_\_\_





-  Practice holding the tin whistle properly
-  Practice making loud and soft sounds
-  Play the D scale
-  Play the hymn

Complete the checklist below by finding each of the symbols in this piece of music.

The musical score consists of two systems of piano music in 4/4 time. The first system starts with a treble clef, a 4/4 time signature, and a dynamic marking of *f* (forte). The melody in the treble clef includes a dotted half note, followed by quarter notes, and ends with a whole note. The bass clef part consists of whole notes. The second system starts with a dynamic marking of *p* (piano) in the treble clef and *f* in the bass clef. The treble clef part features whole notes and a half note, ending with a repeat sign. The bass clef part features quarter notes and whole notes.

- Draw a RED circle around each TREBLE CLEF.
- Draw a BLUE square around each BASS CLEF.
- Draw a YELLOW rectangle around the TIME SIGNATURE.
- Draw a PURPLE triangle around the REPEAT SIGN.
- Draw an ORANGE arrow pointing to each BAR LINE.
- Draw a GREEN square around each symbol that tells you to play LOUDLY.
- Draw a BROWN circle around each symbol that tells you to play SOFTLY.
- Draw a PURPLE triangle around each HALF NOTE.
- Draw a RED arrow pointing to each QUARTER NOTE.
- Draw a YELLOW oval around each WHOLE NOTE.
- Draw a BLUE rectangle around each DOTTED HALF NOTE.

# Copywork



Sing the wondrous love of Jesus, Sing His mercy and His grace;  
In the mansions bright and blessed He'll prepare for us a place.  
When we all get to heaven, What a day of rejoicing that will be!  
When we all see Jesus, We'll sing and shout the victory!

Handwriting practice lines consisting of 10 sets of three horizontal lines (top, middle dashed, bottom) for copying the text above.



# Extension Activities



Draw a picture of the most beautiful mansion you can imagine.



The time of Jesus' return is unknown. Write an encouraging note to someone in your family and hide it in their Bible. Just like Jesus' return, you will never know just when they might find it!



Using a Venn Diagram, compare Eliza Hewitt to Fanny Crosby.



Research other hymns written by Eliza Hewitt that were not mentioned in this lesson. Write out your favorite.



Choose a word from the lesson that you don't know and define it.





# THE STAR-SPANGLED BANNER

## *the story*

After gaining their freedom from the British in 1776, the Americans were still dealing with conflict against their old "mother country" in a new war, The War of 1812. It's during this war that "The Star-Spangled Banner" was written.

The year was 1814. Author Francis Scott Key was a very successful and influential lawyer at the highest level in Washington, D.C., our nation's capitol. He had been sent out by President James Madison to negotiate the release of American prisoners being held a few hundred feet out in the ocean on British ships. After many days of talking, the release of the prisoners was agreed upon, but there was just one problem.

The British told Francis Scott Key of an ultimatum they had given in an attempt to end the war. They told the Americans to surrender their flag, or they would destroy everything in Fort McHenry, Baltimore.

But the Americans refused to surrender. Still on the boat with the prisoners, Francis Scott Key watched as thousands of ships attacked America. With every gun shot and cannon boom, the prisoners from below prayed, "God keep that flag flying where we last saw it."

The sun set over a shoreline filled with despair and hopelessness. After hours of bombs, darkness, and fear, the sun once again rose through a heavy misty fog. Francis Scott Key eagerly looked for the flag. Through the haze he saw the miracle. Though tattered and in shreds, the flag stood. Though crooked and nearly toppled over, the flag stood.

Inspired by the scene of the flag that night, the patriots' bodies lying in a pile holding it up, and the resolve the Americans had to never give up, Francis Scott Key penned the words of "The Star-Spangled Banner."

He wrote it to go with a melody he already knew, and he wrote it with a completely different title, but the song was instantly a hit. In fact, Americans still treasured the song so deeply that President Wilson declared it the national anthem over a century later in 1916.

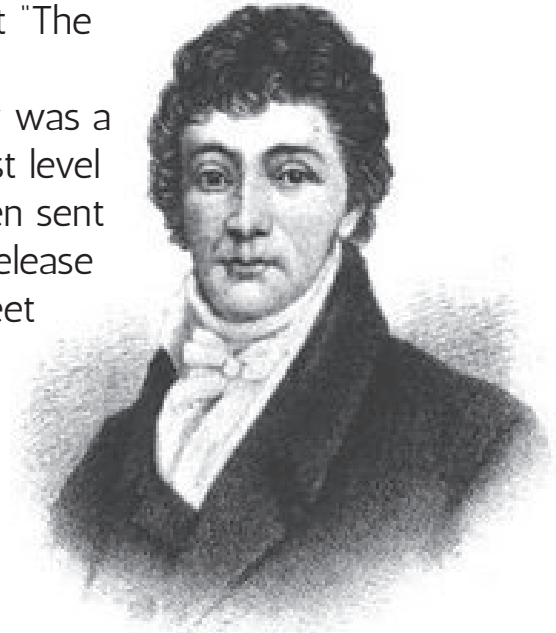

# Hymn Study Notes

NAME OF THE HYMN

---

WRITTEN BY

---

YEAR & LANGUAGE THE HYMN WAS WRITTEN

---

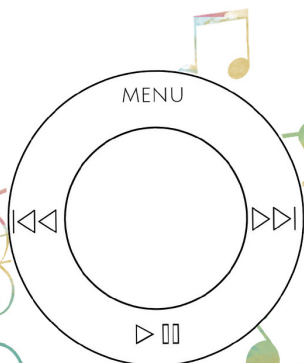

FACTS ABOUT THE AUTHOR



---



---



---



---



---



---

TELL ABOUT THE STORY BEHIND THE HYMN

---

---

---

---

---

---

---



# Bible LESSON

Most people don't know "The Star-Spangled Banner" has 4 verses. The 4th verse shares the faith both of the author and of so many Americans. Look at the words below.

*O thus be it ever, when freemen shall stand  
Between their loved home and the war's desolation!  
Blest with victory and peace, may the heav'n rescued land  
Praise the Power that hath made and preserved us a nation  
Then conquer we must, when our cause it is just,  
And this be our motto – "In God is our trust"  
And the star-spangled banner in triumph shall wave  
O'er the land of the free and the home of the brave!*

Notice the line that says "And this be our motto." Circle the words of the motto. Have you ever seen those words anywhere else?

---

---

---

If you can't remember, go grab a coin out of your piggy bank and read both sides. In 1864, the US Department of Treasury (the people in charge of making money) added this motto to the US coins because of increased emphasis on our need to trust God during the Civil War. Later they even added it to paper money.

I'm reminded of Psalm 20:7. How do you think this verse relates to the lines of "The Star-Spangled Banner?"

---

---

---



"In God We Trust" is indeed the motto of Americans. It's been said that America was so successful in battle against Britain and other countries because they first trusted God.

This should be the motto for our lives, too. In God we trust. Psalm 118:8 is a great verse to help us remember why this motto is so important. Write the verse below.

---

---

---

---

Write a prayer to God, thanking Him for allowing you to live in a country where you are free to worship Him. So many people don't have that ability and we don't know if we always will either. This is one thing we need to be constantly grateful for.

---

---

---

---

---

---

---

---

---

---





---

---







-  Practice holding the tin whistle properly
-  Practice making loud and soft sounds
-  Play the D scale
-  Play the hymn

The instruments of the orchestra are listed in the Word Bank below. Write each instrument's name in the correct instrument family section.

trumpet	oboe	cymbals	French horn	trombone
bass drum	viola	string bass	clarinet	timpani
cello	bassoon	euphonium	harp	violin
xylophone	saxophone	piano	snare drum	chimes
gong	tuba	piccolo	glockenspiel	
guitar				



## STRING FAMILY

1. \_\_\_\_\_
2. \_\_\_\_\_
3. \_\_\_\_\_
4. \_\_\_\_\_
5. \_\_\_\_\_
6. \_\_\_\_\_



## BRASS FAMILY

1. \_\_\_\_\_
2. \_\_\_\_\_
3. \_\_\_\_\_
4. \_\_\_\_\_
5. \_\_\_\_\_
6. \_\_\_\_\_



## WOODWIND FAMILY

1. \_\_\_\_\_
2. \_\_\_\_\_
3. \_\_\_\_\_
4. \_\_\_\_\_
5. \_\_\_\_\_
6. \_\_\_\_\_



## PERCUSSION FAMILY

1. \_\_\_\_\_
2. \_\_\_\_\_
3. \_\_\_\_\_
4. \_\_\_\_\_
5. \_\_\_\_\_
6. \_\_\_\_\_



# Copywork

O say can you see, by the dawn's early light,  
What so proudly we hailed at the twilight's last gleaming,  
Whose broad stripes and bright stars through the perilous fight,  
O'er the ramparts we watched, were so gallantly streaming?  
And the rockets' red glare, the bombs bursting in air,  
Gave proof through the night that our flag was still there;  
O say does that star-spangled banner yet wave  
O'er the land of the free and the home of the brave?

Handwriting practice lines consisting of solid top and bottom lines with a dashed midline, repeated 10 times.



# UNLOCK THE STAR-SPANGLED BANNER CODE

Answer the questions from the story to unlock the code

1. Who wrote "The Star-Spangled Banner"?

\_\_\_\_\_ 12

2. In what year was "The Star-Spangled Banner" written (spelled out)?

\_\_\_\_\_ 2

3. What have we been blessed with \_\_\_\_\_ and \_\_\_\_\_

4. Who is the power that hath made and preserved our nation? \_\_\_\_\_

5. Who were the Americans fighting against in the war? \_\_\_\_\_

6. What part of the day is twilight? \_\_\_\_\_

7. What word in the song is in the morning? \_\_\_\_\_

8. What word in the song means dangerous? \_\_\_\_\_





9. What gave off a red glare? \_\_\_\_\_

10. Who is responsible for making the money we use?  
\_\_\_\_\_ of Treasury.

1    2    3    4    5    6    7    8    9    10    11    12

# Extension Activities



 <p>Use a dictionary to define the word patriotism.</p>	 <p>Learn 5-10 facts about the War of 1812. Dress up and make a video telling what you learned.</p>
 <p>Watch a YouTube video with your parents, taking a tour of the US Treasury.</p>	 <p>Learn about the history of the American flag and write a 3 paragraph report on what you learn.</p>
 <p>List or draw pictures of some things you can do to show patriotism.</p>	





# MY COUNTRY, 'TIS OF THEE

*the story*

One of the most popular patriotic hymns, this song was written by Samuel Francis Smith. After attending Boston Latin School, he attended Harvard and then Andover Seminary. It was there Samuel was drawn to the work of Adoniram Judson, America's first missionary, and developed a growing passion for evangelism.

During this time, hymn publisher Lowell Mason sought help translating a large collection of German songs. Because Samuel was proficient in the German language, he recruited the young man to help him.

On a bitter cold February afternoon, half an hour before sunset, Samuel sat poring over his materials. He was awestruck at the words of "God Bless our Saxon Land," set to the tune we know today as "America."

"I instantly felt the impulse to write a patriotic hymn of my own adapted to this tune." Samuel later said, "Picking up a scrap of paper which lay near me, I wrote at once, probably within half an hour, the hymn, 'America' as it is now known."

William Jenks, a friend of Samuel's, took the song to a pastor. This hymn was first sung on the Fourth of July, 1831, by a youth choir at a Sunday School rally.

Throughout the next couple of years, Samuel grew into a powerful Baptist preacher, pastor, college professor, hymnist, writer, and missionary advocate. He traveled around, supporting evangelism and was thrilled when his son became a missionary to Rangoon.

Although he wrote many things over his lifetime, he has always been revered for his patriotic hymn written as a 23-year-old student. A friend and Harvard classmate, Oliver Wendell Holmes described him this way at a class reunion:

*And there's a nice youngster of excellent pith,  
Fate tried to conceal him by naming him Smith;  
But he shouted a song for the brave and the free,  
Just read on his medal, "My country, tis of thee!"*



# Hymn Study Notes

NAME OF THE HYMN

---

WRITTEN BY

---

YEAR & LANGUAGE THE HYMN WAS WRITTEN

---

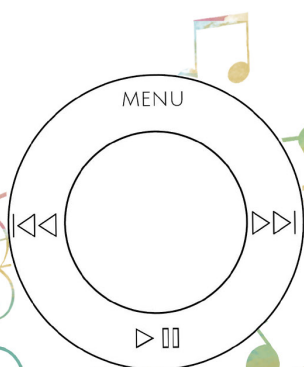

FACTS ABOUT THE AUTHOR



---



---



---



---



---



---

TELL ABOUT THE STORY BEHIND THE HYMN

---

---

---

---

---

---

---



# Bible LESSON

Like "The Star - Spangled Banner" this hymn finds its deepest truth in the final stanza.

*Our fathers' God, to thee,  
Author of liberty, to thee we sing;  
Long may our land be bright  
With freedom's holy light;  
Protect us by thy might, great God, our King.*

As we discussed, our country was founded on the principle of trusting God above men. It is God alone who helps us to prevail both in battle and in everyday life. Looking at the hymn above, what do you think is the most meaningful part?

---

---

Let's read Psalm 33:10 - 12. These verses share another truth about God's protection of our country. Verse 12 specifically gives us one requirement of blessing. What is it?

---

Do you think our country today is recognizing God as our Lord? Name some things going on in our culture that support your answer. (Ask your parents for help if you need to.)

---





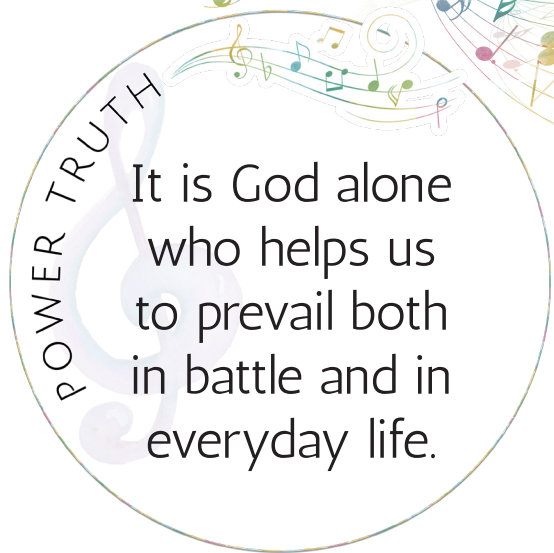

---

---

It doesn't take long to look around and see the condition of our nation. We've taken prayer out of schools and taken down statues of the Ten Commandments. We've made it legal to kill babies and legal to marry someone of the same gender. Instead of obeying God's commands, our culture teaches tolerance and acceptance of the motto "Do what you feel like doing." Most would agree, as a whole our country no longer recognizes God as Lord, nor do we trust Him as such.



As an American, this does seem pretty sad, but there's still hope. 2 Chronicles 7:14 tells us how we can still save our land from the destruction so many other godless countries have faced. Read the verse and list the four things we need to do.

 _____	 _____
 _____	 _____
 _____	 _____
 _____	 _____

If we do these things, what will God do? List all 3 things.

1. \_\_\_\_\_
2. \_\_\_\_\_
3. \_\_\_\_\_

End our lesson today by writing a prayer based on what you've learned. Ask God to forgive our nation for turning away from Him. Ask Him to heal our land and bring revival in our churches. Tell Him what you are willing to do to help!

---



---



---



---







# Copywork

My country, 'tis of thee,  
Sweet land of liberty, of thee I sing;  
Land where my fathers died,  
Land of the pilgrims' pride,  
From every mountainside let freedom ring!

Handwriting practice lines consisting of multiple sets of solid top and bottom lines with a dashed midline.



# MY COUNTRY TIS OF THEE

## *US Symbols*

Instructions: Learn about each of these symbols. Write or draw your findings in the box.

☆☆☆☆☆☆☆☆☆☆☆☆☆☆☆☆☆☆☆☆

LIBERTY BELL

||||||||||||||||||||||||||||||||||||||||

☆☆☆☆☆☆☆☆☆☆☆☆☆☆☆☆☆☆☆☆

AMERICAN FLAG

||||||||||||||||||||||||||||||||||||||||

THE CONSTITUTION

||||||||||||||||||||||||||||||||||||||||

☆☆☆☆☆☆☆☆☆☆☆☆☆☆☆☆☆☆☆☆

THE STATUE OF LIBERTY

☆☆☆☆☆☆☆☆☆☆☆☆☆☆☆☆☆☆☆☆

THE BALD EAGLE

# Extension Activities



Research Adoniram Judson; write a few paragraphs about his life and ministry.



Find out how many languages are spoken in America. If you could learn any language you wanted, what language would you pick and why?



Create a card using red, white and blue. Give it to a veteran or someone in active duty military.



Research and make a list of countries that don't have religious freedom. Also note other freedoms we are blessed with in America that others don't share.



Write an acrostic of the word "freedom" about things you are thankful for.





# AMERICA THE BEAUTIFUL

*the story*

1892 was a very special year in the United States. It was the 400th anniversary of the discovery of America, and the celebration was grand. As an extended part of the festivities, Chicago sponsored a World's Fair which was attended by a group of professors from Wellesley College as they traveled to the Rocky Mountains of Colorado to teach a summer school. The women later compared the wonders of the man-made fair to the glories of God's handiwork.



When the summer school was over, they decided to take a trip to Pike's Peak. This huge mountain had an elevation of 14,000 feet, making it a spectacular view. One

of these women, Katharine Lee Bates, later wrote, "We hired a prairie wagon. Near the top we had to leave the wagon and go the rest of the way on mules. I was very tired. But when I saw the view, I felt great joy. All the wonder of America seemed displayed there, with the sea-like expanse...."

It was then and there, as I was looking out over the sea-like expanse of fertile country spreading away so far under those ample skies, that the opening lines of the hymn floated into my mind. When we left Colorado Springs, the four stanzas were penciled in my notebook.... The Wellesley work soon absorbed time and attention again, the notebook was laid aside, and I do not remember paying heed to these verses again until the second summer following, when I copied them out and sent them to *The Congregationalist*, where they first appeared in print July 4, 1895. The hymn attracted an unexpected amount of attention.... In 1904, I rewrote it, trying to make the phraseology more simple and direct."

The revised hymn soon appeared in the *Boston Evening Transcript*, on November 19, 1904. Interestingly, this hymn was a contender for the national anthem, but "The Star-Spangled Banner" was chosen.

# Hymn Study Notes

NAME OF THE HYMN

---

WRITTEN BY

---

YEAR & LANGUAGE THE HYMN WAS WRITTEN

---

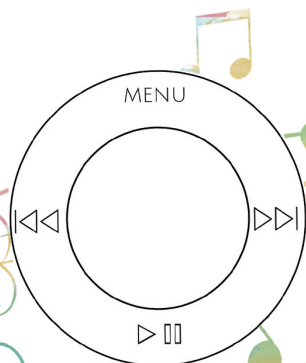

FACTS ABOUT THE AUTHOR



---



---



---



---



---



---

TELL ABOUT THE STORY BEHIND THE HYMN

---

---

---

---

---

---

---



# Bible LESSON

In this hymn, the writer is marveling at the beauty of America. Look over the lyrics of the first verse and record the beautiful things she lists.



---

---

---

---



---

---

---

---

Read Genesis 1:1. How did all of these beautiful things get there?

---

John 1:3 takes it a step further. Write that verse below.

---

---

Psalm 95:4-5 also shares this truth. Read the verse, then think about your favorite parts of creation. Draw or write those things in the box below.



What does Psalm 19:1 share on this topic?

---

---

Even if we don't praise the Lord or appreciate His creation, the very creation itself will do that for us. Read Isaiah 55:12 and illustrate this verse. It's so amazing to think of this truth!

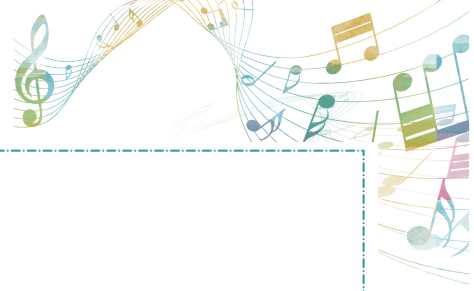

Let's think about the last part of the first verse of "America the Beautiful." Here are the words:

*God shed His grace on thee.  
And crown thy good with brotherhood  
from sea to shining sea.*

Based on what you've learned in this study, write about God's grace. Write specifically about how much we all need it and how much our country needs it.

---

---

---

---

---

Using a dictionary, look up the word "brotherhood." What do you think it means in this song?

---

---







Jesus told us that the greatest commandment is to love God with all of our heart and to love our neighbors. Let's end this study by making a list of ways you can love your neighbors, family, and friends. List ways you can serve them. Once you've made your list, pray and ask God to help you do some of those things.

\_\_\_\_\_  
 \_\_\_\_\_  
 \_\_\_\_\_  
 \_\_\_\_\_  
 \_\_\_\_\_

\_\_\_\_\_  
 \_\_\_\_\_  
 \_\_\_\_\_  
 \_\_\_\_\_  
 \_\_\_\_\_





-  Practice holding the tin whistle properly
-  Practice making loud and soft sounds
-  Play the D scale
-  Play the hymn

WORD BANK

- |           |         |           |         |          |       |
|-----------|---------|-----------|---------|----------|-------|
| Harp      | Piano   | Clarinet  | Timpani | Triangle | Cello |
| Bass clef | Cymbals | Bass drum | Tuba    | Marimba  |       |



# Copywork

O beautiful for spacious skies,  
For amber waves of grain;  
For purple mountain majesties  
Above the fruited plain!  
America! America!  
God shed his grace on thee,  
And crown thy good with brotherhood  
From sea to shining sea!

Handwriting practice lines consisting of multiple sets of solid top and bottom lines with a dashed midline.



# ACROSTIC FOR UNITED STATES

Finish the acrostic by writing words that describe our country.

U \_\_\_\_\_  
N \_\_\_\_\_  
I \_\_\_\_\_  
T \_\_\_\_\_  
E \_\_\_\_\_  
D \_\_\_\_\_  
S \_\_\_\_\_  
T \_\_\_\_\_  
A \_\_\_\_\_  
T \_\_\_\_\_  
E \_\_\_\_\_  
S \_\_\_\_\_

O \_\_\_\_\_  
F \_\_\_\_\_  
A \_\_\_\_\_  
M \_\_\_\_\_  
E \_\_\_\_\_  
R \_\_\_\_\_  
I \_\_\_\_\_  
C \_\_\_\_\_  
A \_\_\_\_\_

# Extension Activities



Draw a picture describing the words from this hymn.



Print a map of the United States and find your state. Color any states where you have friends/family. Also color places you've visited and want to visit. Make each category a different color.



Write a letter to an atheist defending your belief about creation. Use [Answersingenesis.org](http://Answersingenesis.org) if you need help.



The writer of this hymn was a professor at Wellesley College. Where do you want to go to college? Write a few paragraphs describing the school you wish to attend and the reasons you want to go there.



Make a picture collage of beautiful scenery around our country. Label each location.







# APPENDIX:

## *Hymns & Tin Whistle Tablatures*

	Hymn	Tablature
He Keeps Me Singing .....	262 .....	306
Amazing Grace .....	263 .....	307
Blessed Assurance .....	264 .....	308
Take My Life and Let It Be .....	265 .....	309
What a Friend We Have in Jesus .....	266 .....	310
A Mighty Fortress Is Our God .....	267 .....	311
It Is Well with My Soul .....	269 .....	312
I Have Decided to Follow Jesus .....	271 .....	313
Count Your Blessings .....	272 .....	314
Praise God From Whom All Blessings Flow .....	273 .....	316
Great Is Thy Faithfulness .....	274 .....	317
O Come, O Come, Emmanuel .....	276 .....	319
Silent Night .....	277 .....	320
God Rest Ye Merry, Gentlemen .....	278 .....	321
Joy to the World .....	280 .....	322
O For a Thousand Tongues to Sing .....	281 .....	323
'Tis So Sweet to Trust in Jesus .....	282 .....	324
Turn Your Eyes Upon Jesus .....	284 .....	325
I Stand Amazed in the Presence .....	285 .....	327
Be Thou My Vision .....	286 .....	328
Stand Up, Stand Up For Jesus .....	287 .....	329
Come, Thou Fount of Every Blessing .....	288 .....	330
Jesus Paid It All .....	290 .....	331
At Calvary .....	291 .....	332
Christ the Lord Is Risen Today .....	292 .....	333
He Lives .....	294 .....	334
In the Garden .....	296 .....	336
Trust and Obey .....	297 .....	337
When We All Get to Heaven .....	299 .....	338
The Star-Spangled Banner .....	301 .....	339
My Country, 'Tis of Thee .....	303 .....	341
America the Beautiful .....	304 .....	342

# HE KEEPS ME SINGING

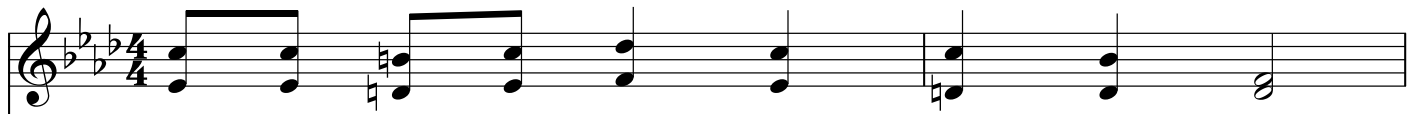

1. There's with - in my heart a me - lo - dy  
 2. All my life was wrecked by sin and strife,  
 3. Though some - times he leads through wa - ters deep,  
 4. Feas - ting on the rich - es of his grace,  
 5. Soon he's co - ming back to wel - come me

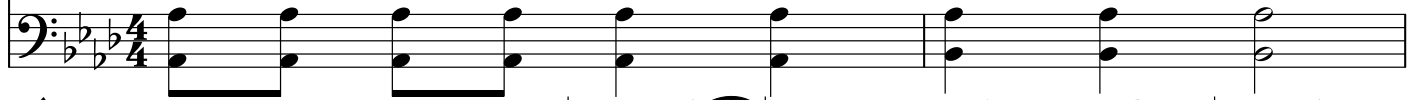

Je - sus whis - pers sweet and low:— Fear not, I am with thee,  
 dis - cord filled my heart with pain;— Je - sus swept a - cross the  
 tri - als fall a - cross the way,— though some - times the path seems  
 re - sting neath his shel - tering wing,— al - ways look - ing on his  
 far be - yond the star - ry sky;— I shall wing my flight to



peace, be still, in all of life's ebb and flow.  
 bro - ken strings, stirred the slum - bering chords a - gain.  
 rough and steep, see his foot - prints all the way.  
 smi - ling face, that is why I shout and sing.  
 worlds un - known; I shall reign with him on high.



*Refrain*



Je - sus, Je - sus, Je - sus, sweet - est name I know,

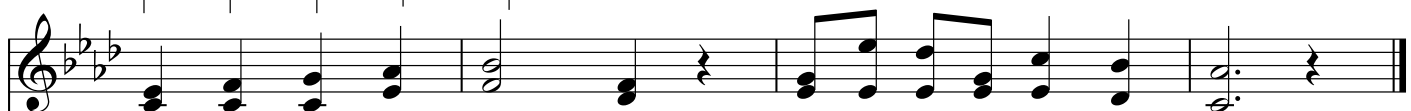

fills my ev - ery long - ing, keeps me sing - ing as I go.

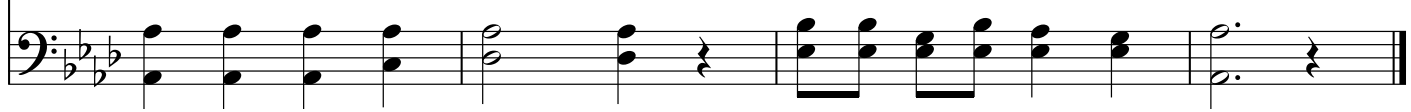

# AMAZING GRACE

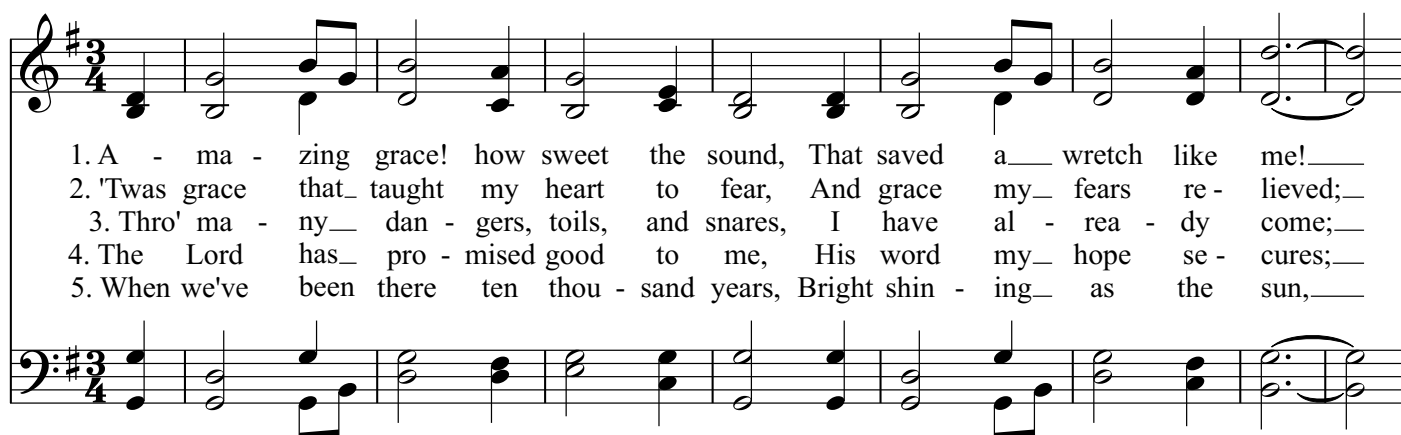

1. A - ma - zing grace! how sweet the sound, That saved a wretch like me! —  
2. 'Twas grace that taught my heart to fear, And grace my fears re - lieved; —  
3. Thro' ma - ny dan - gers, toils, and snares, I have al - rea - dy come; —  
4. The Lord has pro - mised good to me, His word my hope se - cures; —  
5. When we've been there ten thou - sand years, Bright shin - ing as the sun, —



I once was lost, but now am found, Was blind, but now I see.  
How pre - cious did that grace ap - pear The hour I first be - lieved!  
'Tis grace hath bro't me safe thus far, And grace will lead me home.  
He will my shield and por - tion be As long as life en - dures.  
We've no less days to sing God's praise Than when we first be - gun.



# BLESSED ASSURANCE

1 Bles-sed as - su - rance, Je - sus is mine! O what a fore - taste of  
 2 Per - fect sub - mis - sion, per - fect de - light, vi - sions of rap - ture now  
 3 Per - fect sub - mis - sion, all is at rest, I in my Sa - vior am

glo - ry di - vine! Heir of sal - va - tion, pur - chase of God,  
 burst on my sight; an - gels des - cen - ding, bring from a - bove  
 hap - py and blest, watch - ing and wait - ing, look - ing a - bove,

## *Refrain*

born of his Spi - rit, washed in his blood.  
 e - choes of mer - cy, whis - pers of love. This is my sto - ry,  
 filled with his good - ness, lost in his love.

this is my song, prais - ing my Sa - vior all the day long; this is my

sto - ry, this is my song, prais - ing my Sa - vior all the day long.

# TAKE MY LIFE AND LET IT BE



1 Take my life and let it be con - se - crat - ed,  
 2 Take my hands and let them move at the im - pulse  
 3 Take my voice and let me sing al - ways, on - ly,  
 4 Take my sil - ver and my gold; not a mite would

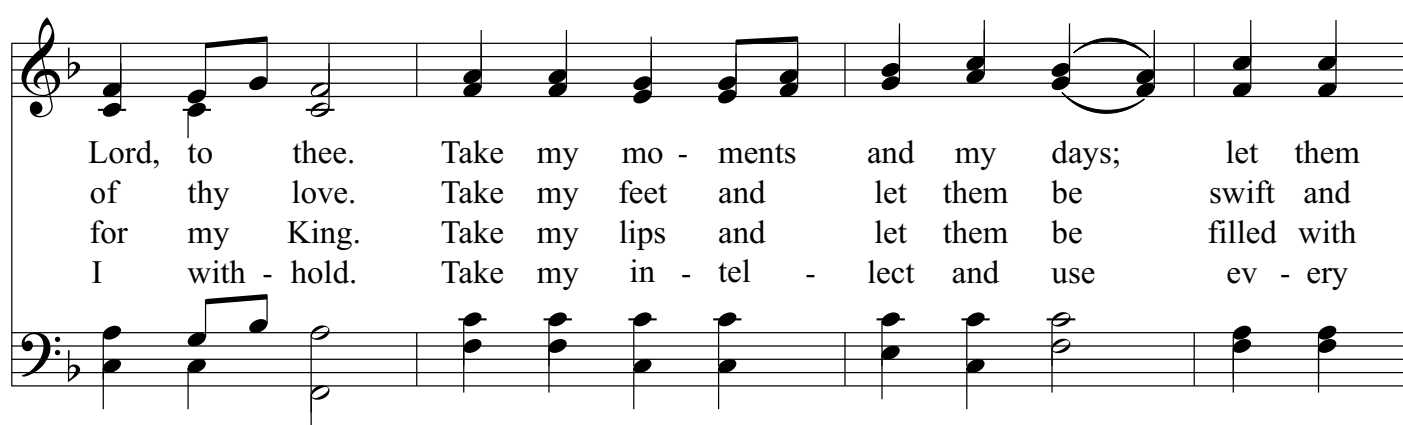

Lord, to thee. Take my mo - ments and my days; let them  
 of thy love. Take my feet and let them be swift and  
 for my King. Take my lips and let them be filled with  
 I with - hold. Take my in - tel - lect and use ev - ery

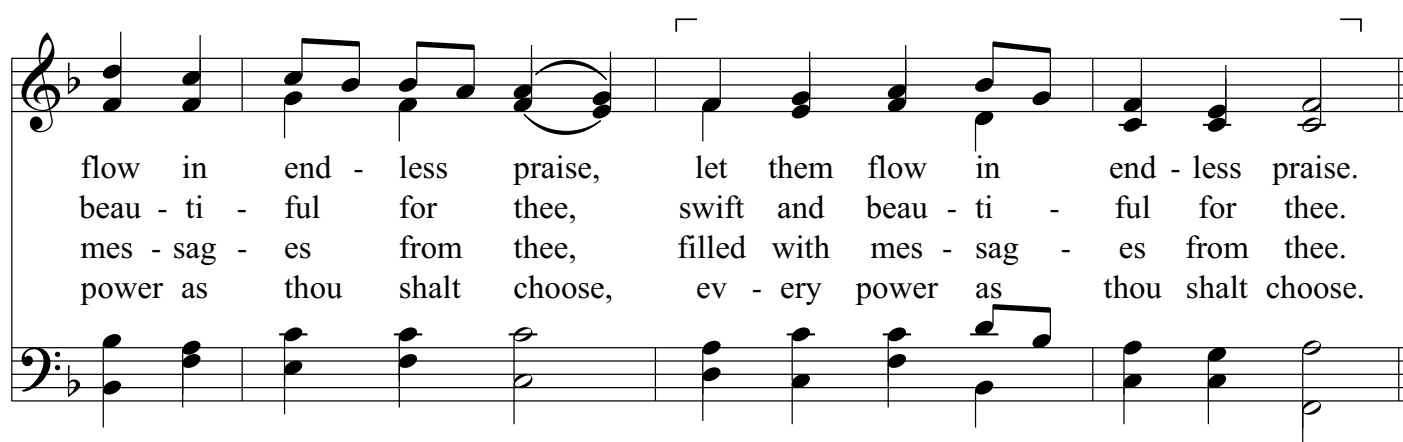

flow in end - less praise, let them flow in end - less praise.  
 beau - ti - ful for thee, swift and beau - ti - ful for thee.  
 mes - sag - es from thee, filled with mes - sag - es from thee.  
 power as thou shalt choose, ev - ery power as thou shalt choose.

5 Take my will and make it thine;  
 it shall be no longer mine.  
 Take my heart—it is thine own;  
 it shall be thy royal throne,  
 it shall be thy royal throne.

6 Take my love; my Lord, I pour  
 at thy feet its treasure store.  
 Take myself, and I will be  
 ever, only, all for thee,  
 ever, only, all for thee.

# WHAT A FRIEND WE HAVE IN JESUS

1. What a friend we have in Je - sus, all our sins and griefs to bear!  
 2. Have we trials and temp-ta - tions? — Is there trou-ble a - ny- where?  
 3. Are we weak and hea - vy la - den, cum - bered with a load of care?

What a pri - vi - lege to car - ry eve - ry - thing to God in prayer!  
 We should ne - ver be dis - cour - aged; take it to the Lord in prayer!  
 Pre - cious Sav - ior still our ref - uge— take it to the Lord in prayer!

Oh, what peace we of - ten for - feit, oh, what need - less pain we bear,  
 Can we find a friend so faith - ful who will all our sor - rows share?  
 Do thy friends des - pise, for - sake thee? Take it to the Lord in prayer!

all be - cause we do not car - ry eve - ry - thing to God in prayer!  
 Je - sus knows our eve - ry weak - ness; take it to the Lord in prayer.  
 In his arms he'll take and shield thee; thou wilt find a so - lace there.

# A MIGHTY FORTRESS IS OUR GOD

A might - y for - tress is our God, a bul - wark  
 Did we in our own strength con - fide, our striv - ing  
 And though this world, with dev - ils filled, should threat - en  
 That Word a - bove all earth - ly powers—no thanks to

nev - er fail - ing; our help - er he, a - mid the flood  
 would be los - ing, were not the right Man on our side,  
 to un - do us, we will not fear, for God has willed  
 them— a - bid - eth; the Spir - it and the gifts are ours

of mor - tal ills pre - vail - ing. For still our an - cient foe  
 the Man of God's own choos - ing. You ask who that may be?  
 his truth to tri - umph through us. The prince of dark - ness grim,  
 through him who with us sid - eth. Let goods and kin - dred go,

does seek to work us woe; his craft and power are great,  
 Christ Je - sus, it is he; Lord Sa - ba - oth his name,  
 we trem - ble not for him; his rage we can en - dure,  
 this mor - tal life al - so; the bod - y they may kill:

and armed with cru - el hate, on earth is not his e - qual.  
 from age to age the same; and he must win the bat - tle.  
 for lo! his doom is sure; one lit - tle word shall fell him.  
 God's truth a - bid - eth still; his king - dom is for - ev - er!

# IT IS WELL WITH MY SOUL

1 When peace like a riv - er at - tend - eth my way, when  
2 Though Sa - tan should buf - fet, though tri - als should come, let  
3 My sin— oh, the bliss of this glo - ri - ous thought!— my

sor - rows like sea bil - lows roll; what - ev - er my lot, thou hast  
this blest as - su - rance con - trol: that Christ has re - gard - ed my  
sin, not in part, but the whole, is nailed to the cross, and I

taught me to say, "It is well, it is well with my soul."  
help - less es - tate, and has shed his own blood for my soul.  
bear it no more; praise the Lord, praise the Lord, O my soul!

*Refrain (may be sung after final stanza only)*

It is well with my soul;  
it is well with my soul;

it is well, it is well with my soul.

# I HAVE DECIDED TO FOLLOW JESUS

1. I have de-cid-ed to fol-low Je-sus, I have de-  
 2. The world be-hind me, the cross be-fore me, The world be-  
 3. Though none go with me, I still will fol-low, Though none go  
 4. Will you de-cide now to fol-low Je-sus? Will you de-

cid-ed to fol-low Je-sus, I have de-cid-ed to fol-low  
 hind me, the cross be-fore me, The world be-hind me, the cross be-  
 with me, I still will fol-low, Though none go with me, I still will  
 cide now to fol-low Je-sus? Will you de-cide now to fol-low

Je - sus— no turn-ing back, no turn-ing back.  
 fore me— no turn-ing back, no turn-ing back.  
 fol - low— no turn-ing back, no turn-ing back.  
 Je - sus?— no turn-ing back, no turn-ing back.



# COUNT YOUR BLESSINGS

1. When up - on life's bil - lows you are temp - est tossed,      When you are dis -  
 2. Are you e - ver bur - dened with a load of care?      Does the cross seem  
 3. When you look at o - thers with their lands and gold,      Think that Christ has  
 4. So, a - mid the con - flict, whe - ther great or small,      Do not be dis -

cour aged, thin - king all is lost,      Count your ma - ny bles - sings, name them  
 hea - vy you are called to bear?      Count your ma - ny bles - sings, ev' - ry  
 pro - mised you His wealth un - told;      Count your ma - ny bles - sings, mo - ney  
 cour aged, God is o - ver all;      Count your ma - ny bles - sings, an - gels

one by one,      And it will sur - prise you what the Lord hath done.  
 doubt will fly,      And you will be sing - ing as the days go by.  
 can - not buy      Your re - ward in hea - ven, nor your home on high.  
 will at - tend,      Help and com - fort give you to your jour - ney's end.

Count your bles - sings, name them one by one;      Count your  
 Count your man - y bles - sings,      name them one by one;      Count your man - y

bles-sings, see what God hath done; Count your bles-sings, -  
 bles-sings, see what God hath done; Count your man-y bles-sings,

name them one by one; Count your ma-ny bles-sings, see what God hath done.

## PRAISE GOD FROM WHOM ALL BLESSINGS FLOW

Praise God, from whom all bles-sings flow; Praise Him, all crea-tures here be-low;

Praise Him a-bove, ye heav'n-ly host; Praise Fa-ther, Son, and Ho-ly Ghost. A-men.

# GREAT IS THY FAITHFULNESS

1 Great is thy faith-ful-ness, O God my Fa-ther;  
2 Sum-mer and win-ter and spring-time and har-vest,  
3 Par-don for sin and a peace that en-dur-eth,

The first system of music consists of two staves. The upper staff is in treble clef with a key signature of two sharps (F# and C#) and a 3/4 time signature. The lower staff is in bass clef with the same key signature and time signature. The lyrics are printed below the upper staff.

5

there is no shad-ow of turn-ing with thee;  
sun, moon, and stars in their cours-es a-bove  
thy own dear pres-ence to cheer and to guide,

The second system of music consists of two staves. The upper staff is in treble clef with a key signature of two sharps and a 3/4 time signature. The lower staff is in bass clef with the same key signature and time signature. The lyrics are printed below the upper staff.

9

thou chang-est not, thy com-pas-sions, they fail not;  
join with all na-ture in man-i-fold wit-ness  
strength for to-day and bright hope for to-mor-row-

The third system of music consists of two staves. The upper staff is in treble clef with a key signature of two sharps and a 3/4 time signature. The lower staff is in bass clef with the same key signature and time signature. The lyrics are printed below the upper staff.

13

as thou hast been thou for - ev - er wilt be.  
to thy great faith - ful - ness, mer - cy, and love.  
bless - ings all mine, with ten thou - sand be - side!

17 *Refrain (may be sung after stanza 3 only)*

Great is thy faithfulness! Great is thy faithfulness! Morning by

22

morn - ing new mer - cies I see; all I have need - ed thy

27

hand hath pro - vided. Great is thy faithfulness, Lord, un to me!

# O COME, O COME, EMMANUEL

1 O come, O come, Im - man - u - el, and ran - som cap - tive  
 2 O come, O Wis - dom from on high, who or - dered all things  
 3 O come, O come great Lord of might, who to your tribes on  
 4 O come, O Branch of Jes - se's stem, un - to your own and

Is - ra - el that mourns in lone - ly ex - ile here  
 might - i - ly to us the path of knowl - edge show  
 Si - nai's height in an - cient times did give the law  
 res - cue them! From depths of hell your peo - ple save,

*Refrain*

un - til the Son of God ap - pear.  
 and teach us in its ways to go. Re - joice! Re -  
 in cloud and maj - es - ty and awe.  
 and give them vic - tory o'er the grave.

joice! Im - man - u - el shall come to you, O Is - ra - el

# SILENT NIGHT

1 Si - lent night, ho - ly night! All is calm, all is bright  
 2 Si - lent night, ho - ly night! Shep - herds quake at the sight,  
 3 Si - lent night, ho - ly night! Son of God, love's pure light,

'round yon vir - gin mo - ther and child; ho - ly in - fant, so ten - der and  
 glo - ries stream\_ from hea - ven a - far, heaven - ly hosts\_ sing al - le - lu -  
 ra - dant beams\_ from thy ho - ly face, with the dawn of re - deem - ing

mild, sleep in hea - ven - ly peace, — sleep\_ in hea - ven - ly peace.  
 ia; Christ, the Sa - vior, is born! — Chris, the Sa - vior, is born!  
 grace, Je - sus, Lord, at thy birth, — Je - sus, Lord, at thy birth.

# GOD REST YE MERRY, GENTLEMEN

1. God rest ye mer - ry gen - tle-men; Let noth - ing you dis - may.  
 2. From God our Heav'n - ly Fa - ther, A bless - ed an - gel came  
 3. "Fear not, then," said the an - gel, "Let noth - ing you af - fright;  
 4. Now to the Lord sing prais - es, All you with - in this place;

Re - mem - ber Christ our Sav - ior Was born on Christ - mas Day  
 And un - to cer - tain shep - herds Brought ti - dings of the same,  
 This day is born a Sav - ior Of a pure vir - gin bright,  
 And with true love and broth - er - hood Each oth - er now em - brace;

To save us all from Sa - tan's pow'r When we were gone a - stray.  
 How that in Beth - le - hem was born The Son of God by name.  
 To free all those who trust in Him From Sa - tan's pow'r and might."  
 This ho - ly tide of Christ - mas All oth - ers doth de - face.

*Refrain*

O ti - dings of com - fort and joy, Com-fort and

joy. O ti - dings of com - fort and joy.



# JOY TO THE WORLD

D A<sup>7</sup> D G A

1 Joy to the world! the Lord is come: let earth re - ceive her  
 2 Joy to the earth! the Sav - ior reigns; let all their songs em -  
 3 No more let sin and sor - row grow nor thorns in - fest the  
 4 He rules the world with truth and grace, and makes the na - tions

D

King. Let ev - ery heart pre - pare him  
 ploy, while fields and floods, rocks, hills, and  
 ground; he comes to make his bless - ings  
 prove the glo - ries of his right - eous -

A

room, and heaven and na - ture sing, and heaven and na - ture  
 plains re - peat the sound - ing joy, re - peat the sound ing  
 flow far as the curse is found, far as the curse is  
 ness and won - ders of his love, and won - ders of his  
 and heaven and na - ture sing,

D D/A A<sup>7</sup> D and

sing, and heaven, and heaven and na - ture sing.  
 joy, re - peat, re - peat the sound - ing joy.  
 found, far as, far as the curse is found.  
 love, and won - ders, won - ders of his love.  
 heaven and na - ture sing,

# O FOR A THOUSAND TONGUES TO SING

D G D G Em D G D<sup>7</sup> G D

1 Oh, for a thou - sand tongues to sing my great Re - deem - er's praise,  
 2 My gra - cious Mas - ter and my God, as - sist me to pro - claim,  
 3 The name of Je - sus charms our fears and bids our sor - rows cease;  
 4 He breaks the power of can - celed sin, he sets the pis - oner free;  
 5 He speaks, and, lis - tening to his voice, new life the dead re - ceive;

G C G/D D<sup>7</sup> G

the glo - ries of my God and King, the tri - umphs of his grace!  
 to spread through all the earth a - broad the hon - ors of your name.  
 'tis mu - sic in the sin - ner's ears, 'tis life and health and peace.  
 his blood can make the foul - est clean; his blood a - vails for me.  
 the mourn - ful, bro - ken hearts re - joice; the hum - ble poor be - lieve.

# 'TIS SO SWEET TO TRUST IN JESUS

1. 'Tis so sweet to trust in Je - sus, and to take him  
 2. O how sweet to trust in Je - sus, just to trust his  
 3. Yes, 'tis sweet to trust in Je - sus, just from sin and  
 4. I'm so glad I learned to trust thee, pre - cious Je - sus,

at his word; just to rest up - on his pro - mise,  
 clean - sing blood; and in sim - ple faith to plunge me  
 self to cease; just from Je - sus sim - ply ta - king  
 Sa - vior, friend; and I know that thou art with me,

## *Refrain*

and to know, "Thus saith the Lord."  
 neath the heal - ing, clean - sing flood! Je - sus, Je - sus, how I  
 life and rest, and joy and peace.  
 wilt be with me to the end.

trust him! How I've proved him o'er and o'er! Je - sus, Je - sus,

pre - cious Je - sus! O for grace to trust him more!

# TURN YOUR EYES UPON JESUS

♩=140

1. O soul, are you wear-y and trou - bled? No light in the dark-ness you see?  
 2. Through death in - to life ev - er - last - ing He passed, and we fol - low Him there;  
 3. His Word shall not fail you— He prom - ised; Be - lieve Him, and all will be well:

There's a light for a look at the Sav - ior, And life more a - bun - dant and free!  
 Ov - er us sin no more hath do - min - ion— For more than con - quer - ors we are!  
 Th - en go to a world that is dy - ing, His pe - rfect sal - va - tion to tell!

*Refrain*

Turn your eyes up-on Je - sus, Look full in His won - der - ful face, And the things of

earth will grow strange-ly dim, In the light of His glo-ry and grace.

# I STAND AMAZED IN THE PRESENCE

$\text{♩} = 110$

1. I stand a - mazed in the pre - sence Of Je - sus the Na - za -  
 2. For me it was in the gar - den He prayed: "Not My will, but  
 3. In pi - ty an - gels be - held Him, And came from the world of  
 4. He took my sins and my sor - rows, He made them His ve - ry  
 5. When with the ran - somed in glo - ry His face I at last shall

- rene, And won - der how He could love me, A sin - ner, con - demned, un -  
 Thine." He had no tears for His own griefs, But sweat drops of blood for  
 light To com - fort Him in the sor - rows He bore for my soul that  
 own; He bore the bur - den to Cal - vary, And suf - fered and died a -  
 see, 'Twill be my joy through the ag - es To sing of His love for

*Refrain*

- clean.  
 mine.  
 night. O how mar - ve - lous! O how won - der - ful! And my song shall ev - er be:  
 - lone.  
 me.

O how mar - vel - ous! O how won - der - ful! Is my Sav - ior's love for me!

# BE THOU MY VISION

1 Be thou my vi - sion, O Lord of my heart;  
2 Be thou my wis - dom, and thou my true word;  
3 Rich - es I heed not, nor vain, emp - ty praise,  
4 Light of my soul, af - ter vic - to - ry won,

5

naught be all else to me, save that thou art:  
I ev - er with thee and thou with me, Lord.  
thou mine in - her - i - tance, now and al - ways:  
may I reach heav - en's joys, O heav - en's Sun!

9

thou my best thought by day and by night,  
Thou my soul's shel - ter, thou my high tower,  
thou, and thou on - ly, first in my heart,  
Heart of my own heart, what - ev - er be - fall,

13

wak - ing or sleep - ing, thy pres - ence my light.  
raise thou me heav'n - ward, O Pow'r of my pow'r.  
great God of heav - en, my trea - sure thou art.  
still be my vi - sion, O Rul - er of all.

# STAND UP, STAND UP FOR JESUS

1. Stand up, stand up for Je - sus, Ye sol - diers of the cross;  
 2. Stand up, stand up for Je - sus, The trum - pet call o - bey;  
 3. Stand up, stand up for Je - sus, Stand in his strength a - lone;  
 4. Stand up, stand up for Je - sus, The strife will not be long;

Lift high His roy - al ban - ner, It must not suf - fer loss:  
 Forth to the might - y con - flict, In this His glo - rious day:  
 The arm of flesh will fail you, Ye dare not trust your own:  
 This day the noise of bat - tle, The next, the vic - tor's song:

From vict' - ry un - to vict' - ry His ar - my shall He lead, —  
 Ye who are men, now serve Him A - gainst un - num - bered foes, —  
 Put on the gos - pel ar - mor, Each piece put on with pray'r, —  
 To him who o - ver - com - eth A crown of life shall be; —

Till ev' - ry foe is van - quished, And Christ is Lord in - deed.  
 Let cour - age rise with dan - ger, And strength to strength op - pose.  
 Where du - ty calls, or dan - ger, Be ne - ver wan - ting there.  
 He, with the King of glo - ry, Shall reign e - ter - nal - ly.



# COME, THOU FOUNT OF EVERY BLESSING

D
A7
D
A
D
G
D
A7

1 Come, thou Fount of ev - ery bless - ing, tune my heart to sing thy  
 2 Here I raise my eb - e ne - zer; hith - er by thy help I've  
 3 Oh, to grace how great a debt - or dai - ly I'm con - strained to

D
A7
D
A
D

grace; streams of mer - cy, nev - er ceas - ing, call for  
 come; and I hope, by thy good plea - sure, safe - ly  
 be! Let thy good - ness, like a fet - ter, bind my

G
D
A7
D
A7
D
G

songs of lou - dest praise. Teach me some me - lo - dious  
 to ar - rive at home. Je - sus sought me when a  
 wan - dering heart to thee: prone to wan - der, Lord, I

D A<sup>7</sup> D G D A<sup>7</sup>

son - net, sung by flam - ing tongues a - bove. Praise the  
 strang - er, wan - dering from the fold of God; he, to  
 feel it, prone to leave the God I love; here's my

D A D G D A<sup>7</sup> D

mount— I'm fixed up - on it mount of God's re - deem - ing love.  
 res - cue me from dan - ger, bought me with his pre - cious blood.  
 heart, O take and seal it; seal it for thy courts a - bove.

# JESUS PAID IT ALL

1. I \_\_\_\_\_ hear the Sa - vior say, "Thy stength in - deed is small,  
 2. Lord, \_\_\_\_\_ now in - deed I find Thy pow'r and Thine a - lone,  
 3. For \_\_\_\_\_ noth - ing good have I Where - by Thy grace to claim;  
 4. And \_\_\_\_\_ when, be - fore the throne, I stand in Him com - plete,

Child of weak - ness, watch and pray, Find in Me thine all in all."  
 Can \_\_\_\_\_ change the le - per's spots And \_\_\_\_\_ melt the heart of stone.  
 I'll \_\_\_\_\_ wash my gar - ments white In the blood of Cal - v'ry's Lamb.  
 "Je - sus died my soul to save," My \_\_\_\_\_ lips shall still re - peat.

## *Refrain*

Je - sus paid it all, All to Him I owe;

Sin had left a crim - son stain, He washed it white as snow.

# AT CALVARY

1. Years I spent in va - ni - ty and pride, Ca - ring not my Lord was  
 2. By God's Word at last my sin I learned; Then I trem - bled at the  
 3. Now I've giv'n to Je - sus ev' - ry - thing, Now I glad - ly own Him  
 4. Oh, the love that drew sal - va - tion's plan! Oh, the grace that bro't it

cru - ci - fied, Know - ing not it was for me He died On Cal - va - ry.  
 law I'd spurned, Till my guil - ty soul im - plor - ing turned To Cal - va - ry.  
 as my King. Now my rap - tured soul can on - ly sing Of Cal - va - ry.  
 down to man! Oh, the migh - ty gulf that God did span At Cal - va - ry.

Mer - cy there was great, and grace was free; Par - don there was mul - ti -

plied to me; There my bur - dened soul found li - ber - ty At Cal - va - ry.

# CHRIST THE LORD IS RISEN TODAY

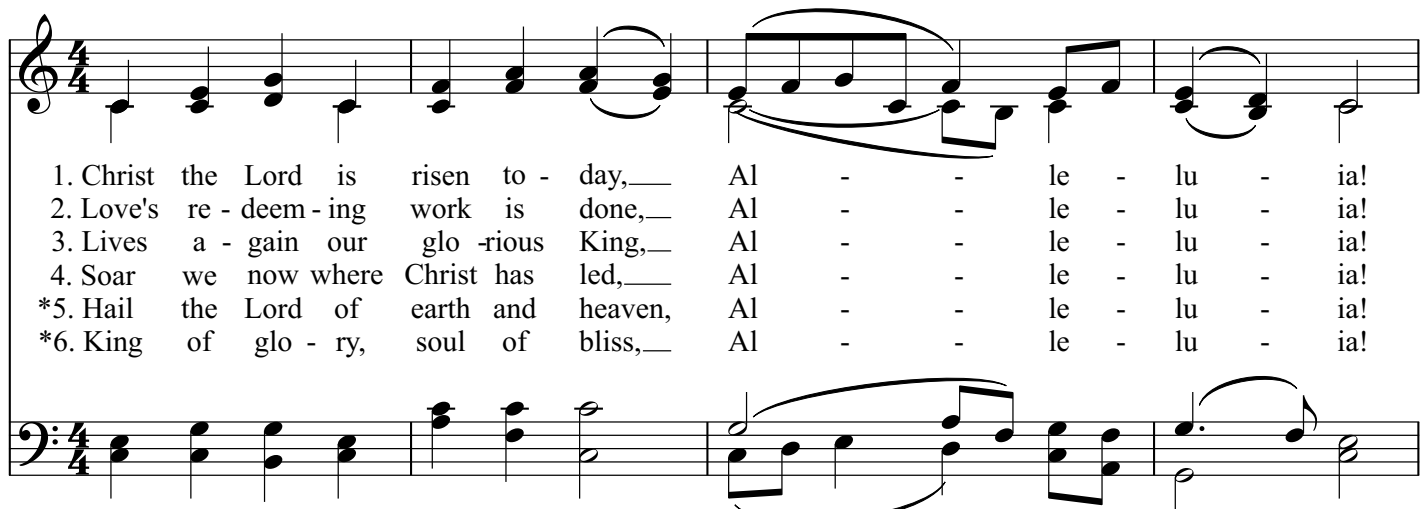

1. Christ the Lord is risen to - day, — Al - - le - lu - ia!  
 2. Love's re - deem - ing work is done, — Al - - le - lu - ia!  
 3. Lives a - gain our glo - rious King, — Al - - le - lu - ia!  
 4. Soar we now where Christ has led, — Al - - le - lu - ia!  
 \*5. Hail the Lord of earth and heaven, Al - - le - lu - ia!  
 \*6. King of glo - ry, soul of bliss, — Al - - le - lu - ia!



Earth and heaven in cho - rus say, — Al - - le - lu - ia!  
 Fought the fight, the bat - tle won, — Al - - le - lu - ia!  
 Where, O death, is now thy sting? — Al - - le - lu - ia!  
 Fol lowing our ex - al - ted Head, — Al - - le - lu - ia!  
 Praise to thee by both be given, — Al - - le - lu - ia!  
 E - ver - las - ting life is this, — Al - - le - lu - ia!

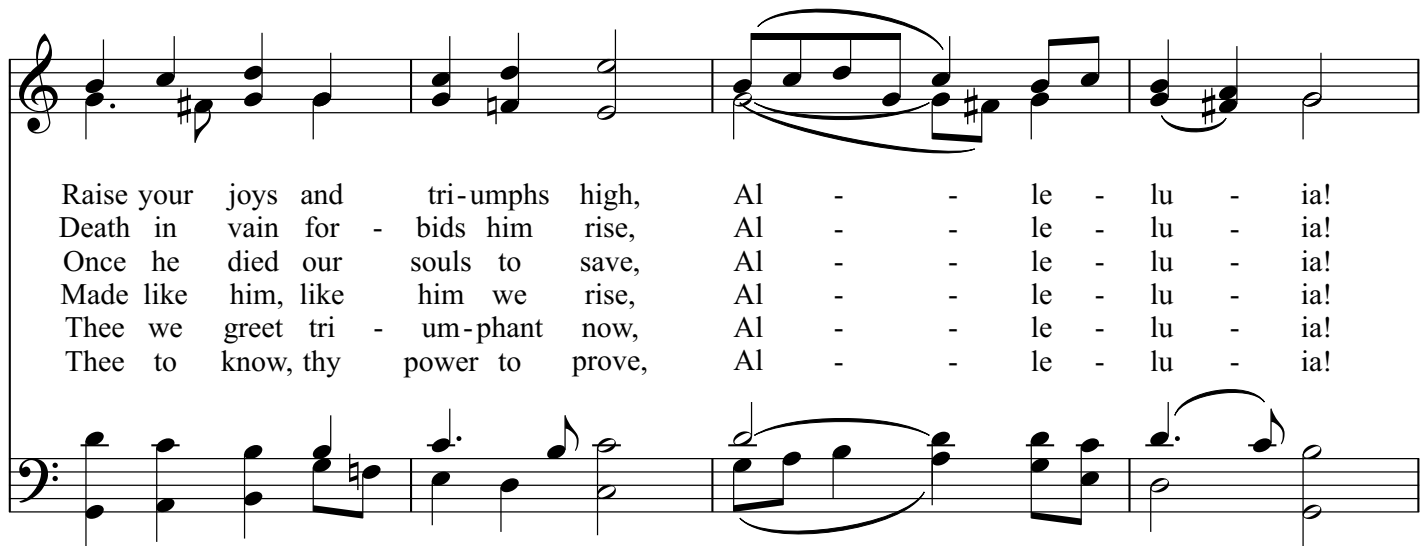

Raise your joys and tri - umphs high, Al - - le - lu - ia!  
 Death in vain for - bids him rise, Al - - le - lu - ia!  
 Once he died our souls to save, Al - - le - lu - ia!  
 Made like him, like him we rise, Al - - le - lu - ia!  
 Thee we greet tri - um - phant now, Al - - le - lu - ia!  
 Thee to know, thy power to prove, Al - - le - lu - ia!

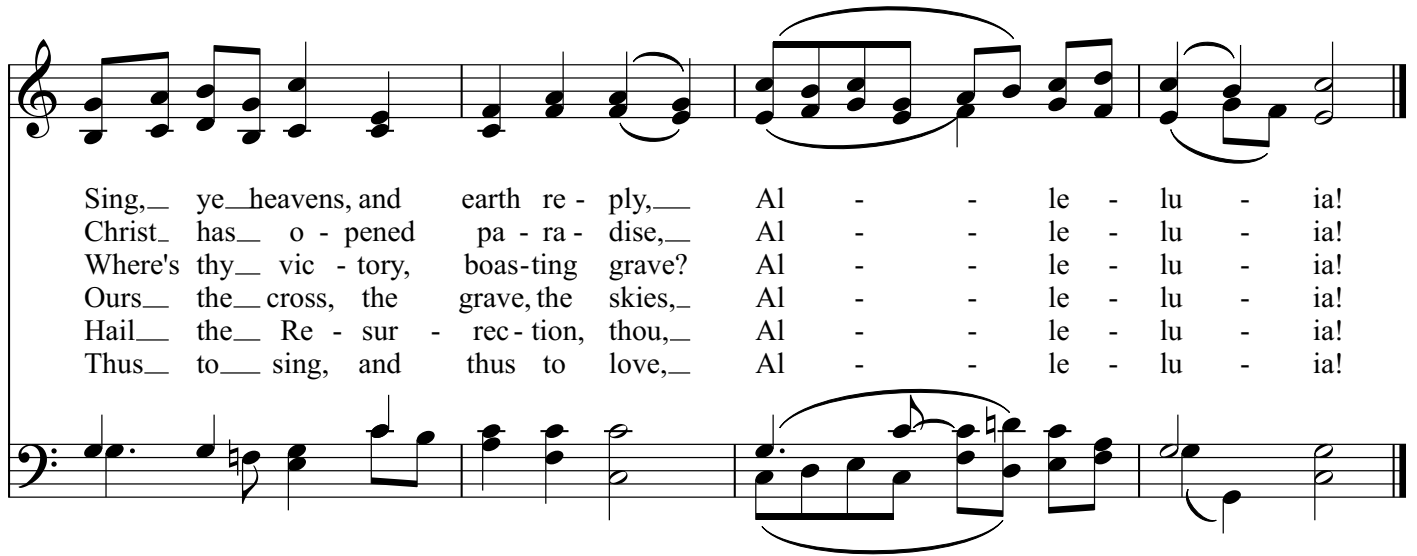

Sing, ye heavens, and earth re - ply, Al - - le - lu - ia!  
 Christ has o - pened pa - ra - dise, Al - - le - lu - ia!  
 Where's thy vic - tory, boas-ting grave? Al - - le - lu - ia!  
 Ours the cross, the grave, the skies, Al - - le - lu - ia!  
 Hail the Re - sur - rec - tion, thou, Al - - le - lu - ia!  
 Thus to sing, and thus to love, Al - - le - lu - ia!

# HE LIVES



1. I serve a ris - en Sav - ior, He's in the world to - day;  
2. In all the world a - round me I see His lov - ing care,  
3. Re - joice, re - joice, O Chris - tian, lift up your voice and sing

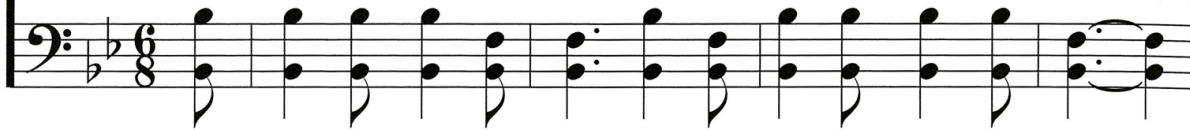

I know that He is liv - ing, what - ev - er men may say;  
And though my heart grows wea - ry, I nev - er will de - spair;  
E - ter - nal hal - le - lu - jahs to Je - sus Christ the King!



I see His hand of mer - cy, I hear His voice of cheer,  
I know that He is lead - ing thru all the storm - y blast,  
The Hope of all who seek Him, the Help of all who find,



And just the time I need Him, He's al - ways near.  
The day of His ap - pear - ing will come at last.  
None oth - er is so lov - ing so good and kind.



He lives, He lives, Christ Je - sus lives to -  
He lives, He lives,

day! He walks with me and talks with me a -

long life's nar - row way. He lives, He  
He lives,

lives, He lives, sal - va - tion to im - part! You

ask me how I know He lives? He lives with-in my heart.



# IN THE GARDEN

1. I come to the gar - den a - lone, While the dew is  
 2. He speaks, and the sound of His voice Is so sweet the  
 3. I'd stay in the gar - den with Him Tho' the night a -

still on the ros - es; And the voice I hear, fal - ling on my ear,  
 birds hush their sing - ing; And the me - lo - dy that He gave to me  
 round me be fal - ling; But He bids me go; thro' the voice of woe,

The Son of God dis - clo - ses.  
 With - in my heart is ring - ing. And He walks with me, and He  
 His voice to me is cal - ling.

talks with me, And He tells me I am His own, And the joy we

share as we tar - ry there, None o - ther has e - ver known.

# TRUST AND OBEY

1. When we walk with the Lord in the light of his word,  
 2. Not a bur - den we bear, not a sor - row we share,  
 3. But we ne - ver can prove the de - lights of his love  
 4. Then in fel - lows - hip sweet we will sit at his feet,

what a glo - ry he sheds on our way!  
 but our toil he doth rich - ly re - pay;  
 un - til all on the al - tar we lay;  
 or we'll walk by his side in the way;

While we do his good will, he a - bides with us still,  
 not a grief or a loss, not a frown or a cross,  
 for the fa - vor he shows, for the joy he bes - tows,  
 what he says we will do, where he sends we will go;

and with all who will trust and o - bey.  
 but is blest if we trust and o - bey.  
 are for them who will trust and o - bey.  
 ne - ver fear, on - ly trust and o - bey.

*Refrain*



Trust and o - bey, for there's no o - ther way to be

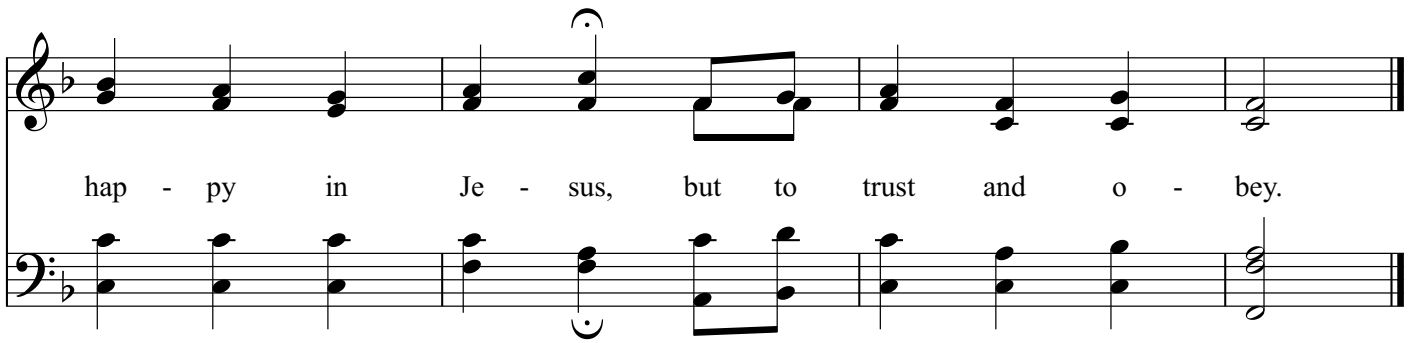

hap - py in Je - sus, but to trust and o - bey.

# WHEN WE ALL GET TO HEAVEN

1. Sing the won - drous love of Je - sus, Sing His mer - cy  
 2. While we walk the pil - grim path - way, Clouds will o - ver  
 3. Let us then be true and faith - ful, Trus - ting, ser - ving  
 4. On - ward to the prize be - fore us! Soon His beau - ty

and His grace; In the man - sions bright and bles - sed,  
 spread the sky; But when trav' - ling days are o - ver,  
 ev' - ry day; Just one glimpse of Him in glo - ry  
 we'll be - hold; Soon the pear - ly gates will o - pen;

He'll pre - pare for us a place. When we all get to  
 Not a sha - dow, nor a sigh.  
 Will the toils of life re - pay.  
 We shall tread the streets of gold. When we all

hea - ven, What a day of re - joic - ing that will be! When we  
 What a day of re - joi - ing that will be!

The image shows a musical score for the hymn 'When We All Get to Heaven'. It consists of two staves: a treble clef staff at the top and a bass clef staff at the bottom. The treble staff contains a vocal melody with lyrics underneath. The bass staff contains a piano accompaniment. The lyrics are: 'all see Je - sus, We'll sing and shout the vic - to - ry. When we all and shout the vic - to - ry.' The music is in a common time signature and features a key signature of one flat (B-flat). The score ends with a double bar line.

# THE STAR-SPANGLED BANNER

1. O say, can you see, by the dawn's ear - ly light,  
2. O thus be it e - ver, when free men shall stand

What so proud - ly we hailed at the twi - light's last gleam - ing,  
Bet - ween their loved homes and the war's de - so - la - tion;

Whose broadstripes and bright stars, thro' the pe - ri - lous fight,  
Blest with vict' - ry and peace, may the heav'n - res - cued land

O'er the ram - parts we watched, were so gal - lant - ly stream - ing?  
Praise the pow'r that hath made and pre - served us a na - tion!

And the rock - ets' red glare, the bombs bur - sting in air,  
Then\_ con - quer we must, when our cause it is just;

Gave proof thro' the night\_ that our flag was still there.  
And this be our mot - to: "In\_ God is our trust!"

O\_ say, does that\_ star - spang - gled ban - ner\_ yet\_  
And the star - span - gled\_ ban - ner in tri - umph\_ shall\_

wave\_ O'er the land\_ of the free and the home of the brave?  
wave\_ O'er the land\_ of the free and the home of the brave.

# MY COUNTRY, 'TIS OF THEE

1. My coun - try' tis of thee, sweet land of  
 2. My na - tive coun - try, thee, land of the  
 3. Let mu - sic swell the breeze, and ring from  
 4. Our fa - thers' God, to thee, au - thor of

li - ber - ty, of thee I sing; land where my  
 no - ble free, thy name I love; I love thy  
 all the trees, sweet free - dom's song; let mor - tal  
 li - ber - ty, to thee we sing; long may our

fa - thers died, land of the pil - grims' pride,  
 rocks and rills, thy woods and tem - pled hills;  
 tongues a - wake; let all that breathe par - take;  
 land be bright with free - dom's ho - ly light;

from ev - ery moun - tain - side let free - dom ring!  
 my heart with rap - ture thrills, like that a - bove.  
 let rocks their si - lence break, the sound pro - long.  
 pro - tect us by thy might, great God, our King.



# AMERICA THE BEAUTIFUL

1. O beau - ti - ful for spa - cious skies, for am - ber waves of  
 2. O beau - ti - ful for he - roes proved in li - be - ra - ting  
 3. O beau - ti - ful for pa - triot dream that sees be - yond the

grain; for pur - ple moun - tain ma - jes - ties a -  
 strife, who more than self their coun - try loved, and  
 years thine a - la - bas - ter ci - ties gleam, un -

bove the fruit - ed plain! A - me - ri - ca! A - me - ri - ca!  
 mer - cy more than life! A - me - ri - ca! A - me - ri - ca!  
 dimmed by hu - man tears! A - me - ri - ca! A - me - ri - ca!

God shed his grace on thee, and crown thy good with  
 May God thy gold re - fine, till all suc - cess be  
 God mend thine ev - ery flaw, con - firm thy soul in

bro - ther - hood from sea to shin - ing sea.  
no - ble - ness, and ev - ery gain di - vine.  
self - con - trol, thy li - ber - ty in law.

# HE KEEPS ME SINGING

Words & Music: Luther Bridges



There's with - in my heart a mel - o - dy; Je - sus whis - pers sweet and



low, — "Fear not, I am with thee, peace, be still," In all of life's ebb and

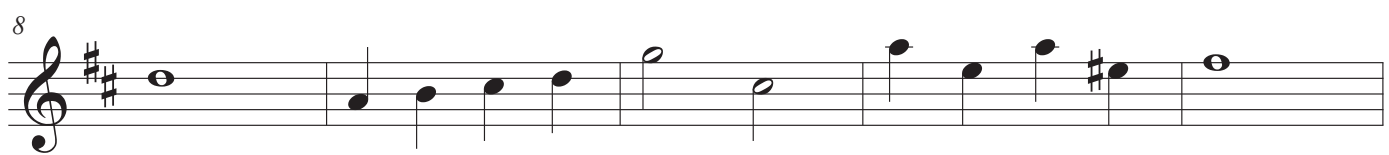

flow. Je - sus, Je - sus, Je - sus, Sweet - est name I know,

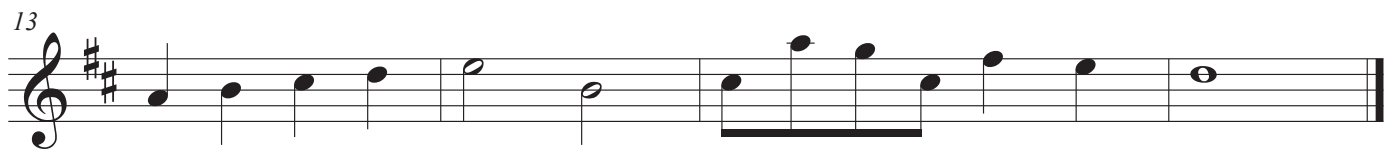

Fills my ev - 'ry long - ing, Keeps me sing - ing as I go.

# AMAZING GRACE

Words: John Newton  
 Music: Virginia Harmony, 1831

A - maz - ing\_\_ grace! How sweet the sound, That saved a\_\_

6

wretch like me! \_\_\_\_\_ I once \_\_\_\_\_ was \_\_\_\_\_ lost, but

11

now \_\_\_\_\_ am \_\_\_\_\_ found, Was blind, but \_\_\_\_\_ now I see. \_\_\_\_\_

# BLESSED ASSURANCE

Words: Fanny Crosby  
Music: Phoebe Knapp

Bles-sed as - sur - ance, Je-sus is mine! O what a fore - taste of glo-ry di -

4

vine! Heir of sal - va - tion, pur-chase of God, Born of His Spir - it, washed in His

8

blood. This is my sto - ry, this is my song, Prais-ing my Sav - ior all the day

12

long; This is my sto - ry, this is my song, Prais-ing my Sav - ior all the day long.

# TAKE MY LIFE AND LET IT BE

Words: Francis Havergal  
 Music: Henri A. C. Malan

7

Take my life, and let it be Con - se - crat - ed,

7

Lord to Thee; Take my hands, and let them

12

move At the im - pulse of Thy

16

love, At the im - pulse of Thy love.

# WHAT A FRIEND WE HAVE IN JESUS

Words: Joseph Scriven  
 Music: Charles Converse

4

What a friend we have in Je - sus, All our sins and griefs to bear!

5

What a priv - i - lege to car - ry Ev - 'ry-thing to God in prayer!

9

O, what peace we of - ten for - feit, O, what need-less pain we bear,

13

All be-cause we do not car - ry Ev - 'ry-thing to God in prayer.

# A MIGHTY FORTRESS IS OUR GOD

Words & Music: Martin Luther

4

A + might - y for - tress is our God, A bul - wark nev - er

4

fail - ing; Our help - er He a - mid the flood Of

8

mor - tal ills pre - vail - ing. For still our an - cient

12

foe Doth seek to work us woe, His craft and pow'r are great, And,

17

armed with cru - el hate, On earth is not his e - qual.



# IT IS WELL WITH MY SOUL

Words: Horatio Spafford  
Music: Philip Bliss

4

When peace like a riv - er at - tend - eth my way, When sor - rows like

6

sea - bil lows roll; What - ev - er my lot, Thou hast taught me to

11

say. "It is well, it is well with my soul." It is

15

well \_\_\_\_\_ with my soul, \_\_\_\_\_ It is well, it is well with my soul.

# I HAVE DECIDED TO FOLLOW JESUS

Words: Unknown  
 Music: Folk melody from India

I have de - cid - ed to fol-low Je - sus; I have de - cid - ed to fol-low

4

Je - sus; I have de - cid - ed to fol-low Je - sus; No turn-ing back, no turn-ing back.

# COUNT YOUR BLESSINGS

Words: Johnson Oatman, Jr.  
Music: Edwin Excell



When up - on life's bil - lows you are tem - pest tossed,

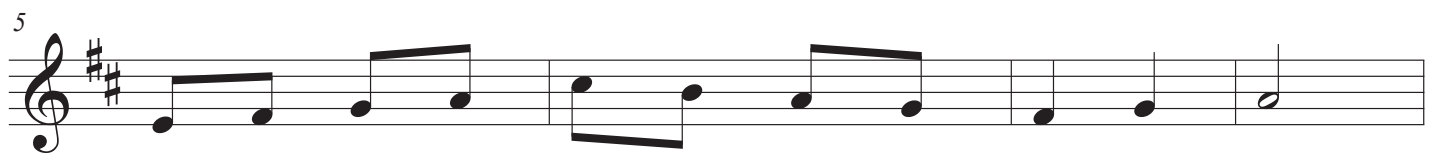

When you are dis - cour - aged think - ing all is lost,



Count your man - y bless - ings name them one by one,



And it will sur - prise you what the Lord has done.

17

Count your bless - ings, name them one by one;

21

Count your bless - ings, see what God has done;

25

Count your bless - ings, name them one by one;

29

Count your man - y bless - ings, see what God has done.

# PRAISE GOD FROM WHOM ALL BLESSINGS FLOW

Words: Thomas Ken  
Music: Genevan Psalter

4

Praise God, from whom all blessings flow; Praise

4

Him, all creatures here below; Praise Him above, ye

8

heav'n - ly host; Praise + Fa - ther, Son, and Ho - ly Ghost!

# GREAT IS THY FAITHFULNESS

Words: Thomas Chisholm  
Music: William Runyan

6/8

Great is Thy faith - ful-ness, O God my Fa - ther! There is no

6

sha - dow of turn - ing with Thee; Thou chang - est not, Thy com -

11

pas - sions they fail not; As Thou hast been Thou for - ev - er wilt be.

17

Great is Thy faith - ful-ness! Great is Thy faith - ful-ness! Morn - ing by

22

morn - ing new mer - cies I see; All I have need - ed Thy

27

hand hath pro - vid - ed; Great is Thy faith - ful-ness, Lord, un - to me!

# O COME, O COME, EMMANUEL

Words: Latin Hymn  
Music: Plainsong, adap. Thomas Helmore

4

O come, O come, Em - man - u - el, And ran - som cap - tive

5

Is - ra - el, That morns in low - ly ex - ile here, Un -

10

til the Son of God \_\_\_\_\_ ap - pear. Re - joice! Re - joice! Em -

15

man - u - el Shall come to Thee, O Is - ra - el!



# SILENT NIGHT

Words: Joseph Mohr  
Music: Franz Gruber

Si - lent night, ho - ly night, All is calm, all is bright

5

Round yon vir - gin mo - ther and child. Ho - ly in - fant so ten - der and mild,

9

Sleep in heav - en - ly peace, — Sleep — in heav - en - ly peace.

# GOD REST YE MERRY, GENTLEMEN

Words: Traditional English Carol  
 Music: 18th Century English Melody

God rest ye mer-ry gen-tle-men, Let noth-ing you dis-may, Re -

5

mem-ber Christ our Sa-vior was born on Christ-mas Day; To save us all from

10

Sa-tan's pow'r When we were gone a-stray, O ti-dings of com-fort and

15

joy, com-fort and joy; O ti-dings of com-fort and joy!

# JOY TO THE WORLD

Words: Isaac Watts  
 Music: George F. Handel

9

Joy to the world! the Lord is come: Let earth re-ceive her King: Let

9

ev - 'ry heart pre - pare Him room, and heav'n and na - ture

14

sing, And heav'n and na-ture sing, And heav'n and heav'n and na-ture sing.

# O FOR A THOUSAND TONGUES TO SING

Words: Charles Wesley  
Music: Carl Glaser



O for a thou - sand tongues to sing My great Re - deem - er's

4

praise, The + glo - ries of my God and King, The — tri - umphs of His grace.

# 'TIS SO SWEET TO TRUST IN JESUS

Words: Louisa Stead  
Music: William Kirkpatrick

1  
  
  
 'Tis so sweet to trust in Je - sus, Just to take Him at His Word,

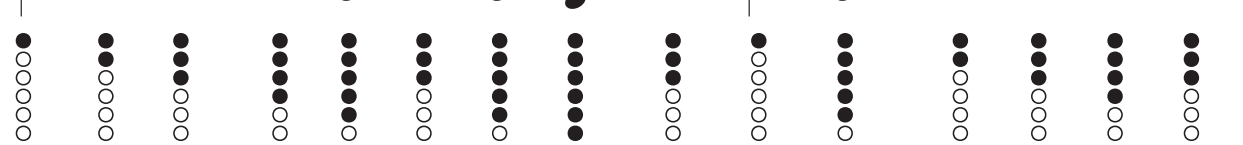
5  
  
  
 Just to rest up - on His pro - mise, Just to know, "Thus saith the Lord."

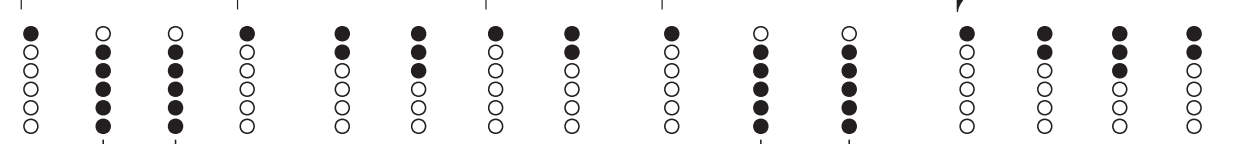
9  
  
  
 Je - sus, Je - sus, how I trust Him! How I've proved Him o'er and o'er!

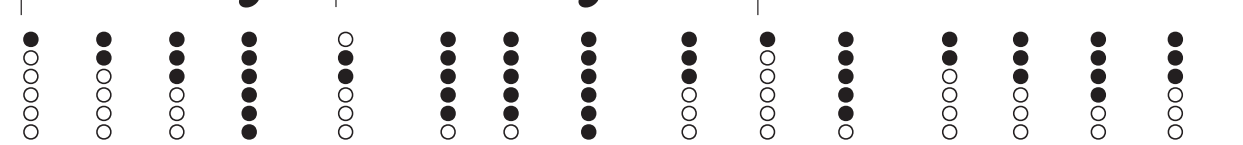
13  
  
  
 Je - sus, Je - sus, pre - cious Je - sus! O for grace to trust Him more!

# TURN YOUR EYES UPON JESUS

Words & Music: Helen Lemmel

1  
  
 O soul, are you wea - ry and trou - bled? No light in the

6  
  
 dark - ness you see? \_\_\_\_\_ There's light for a look at the Sav -

12  
  
 ior, And life more a - bun - dant and free! \_\_\_\_\_ Turn your

18  
  
 eyes up - on Je - sus, Look full in His won - der - ful

23

face, \_\_\_\_\_ And the things of earth will grow strange - ly

28

dim In the light of His glo - ry and grace. \_\_\_\_\_

# I STAND AMAZED IN THE PRESENCE

Words & Music: Charles Gabriel

1

I stand a - mazed in the pres - ence of Je - sus the Naz - a - rene, And

5

won - der how He could love me, A sin - ner, con - demned, un - clean.

9

How mar - ve - lous! How won - der - ful! And my song shall ev - er be;

13

How mar - ve - lous! How won - der - ful! Is my Sav - ior's love for me!



# BE THOU MY VISION

Words: Ancient Irish Hymn  
 Music: Traditional Irish melody

1

Be Thou my Vi - sion, O Lord of my heart; Naught be all

6

else to me, save that Thou art; Thou my best thought, by

11

day or by night; Wak - ing or sleep - ing, Thy pres - ence my light.

# STAND UP, STAND UP FOR JESUS

Words: George Duffield  
Music: George Webb



Stand up, stand up for Je - sus, Ye sol - diers of the cross, Lift



high His roy - al ban - ner, It must not suf - fer loss, From



vic - t'ry un - to vic - t'ry His ar - my shall He lead, — Till



ev - 'ry foe is van - quished And Christ is Lord in - deed.

# COME, THOU FOUNT OF EVERY BLESSING

Words: Robert Robinson  
Music: John Wyeth

Come, Thou Fount of ev-'ry bless-ing, Tune my heart to sing Thy grace; Streams of

5

mer - cy, nev - er ceas - ing, Call for songs of loud-est praise. Teach me —

9

some me - lo-dious son - net Sung by — flam - ing tongues a - bove; Praise the

13

mount, I'm fixed up - on it, Mount of Thy re - deem-ing love.

# JESUS PAID IT ALL

Words: Elvina Hall  
Music: John Grape

I hear the Sav - ior say, "Thy strength in - deed is

4

small! Child of weak - ness, watch and pray, Find in Me thine all in

8

all." Je - sus paid it all, All to Him I owe;

13

Sin had left a crim-son stain; He washed it white as snow.

# AT CALVARY

Words: William Newell  
Music: Daniel Towner

Years I spent in van-i - ty and pride, Car - ing not my Lord was cru - ci - fied,

5

Know - ing not it was for me He died On Cal - va - ry.

9

Mer - cy there was great and grace was free, Par - don there was mul - ti - plied to me,

13

There my bur - dened soul found lib - er - ty, At Cal - va - ry.



# HE LIVES

Words: & Music: Alfred H. Ackley

I serve a ris - en Sav - ior, He's in the world to - day; — I know that He is

6

liv - ing, what - ev - er men may say; — I see His hand of mer - cy, I

11

hear His voice of cheer, — and just the time I need Him, — He's al - ways

16

near. — He lives, — He lives, — Christ Je - sus lives to - day! — He

21

walks with me and talks with me a - long life's nar - row way. He

25

lives, He lives, sal - va - tion to im - part! You

29

ask me how I know He lives? He lives with - in my heart.



# IN THE GARDEN

Words & Music: Austin Miles

I come to the gar-den a - lone, — While the dew is still on the ros - es; And the

5

voice I hear, fal-ling on my ear, The Son of God dis - clos es. And He

10

walks with me, and He talks with me, And He tells me I am His own, — And the

14

joy we share as we tar - ry there, None o - ther has ev - er — known.

# TRUST AND OBEY

Words: John Sammis  
Music: Daniel Towner

3/4

When we walk with the Lord In the light of His Word What a glo - ry He

6

sheds on our way! \_\_\_\_\_ While we do His good will He a - bides with us

12

still, And with all who will trust and o - bey. Trust and o - bey, for there's

18

no oth - er way To be hap - py in Je - sus, But to trust and o - bey.

# WHEN WE ALL GET TO HEAVEN

Words: Eliza Hewitt  
Music: Emily Wilson

4

Diagrammatic notation for the first line, consisting of 13 vertical columns of circles. Each column has 5 circles. The circles are filled (black) or empty (white) to represent fingerings on a tin whistle. Some columns have a '+' sign below them.

Sing the won-drous love of Je - sus, Sing His mer - cy and His grace;

5

Diagrammatic notation for the second line, consisting of 13 vertical columns of circles. Each column has 5 circles. The circles are filled (black) or empty (white) to represent fingerings on a tin whistle. Some columns have a '+' sign below them.

In the man-sions bright and bles - sed, He'll pre - pare for us a place. When we

9

Diagrammatic notation for the third line, consisting of 13 vertical columns of circles. Each column has 5 circles. The circles are filled (black) or empty (white) to represent fingerings on a tin whistle. Some columns have a '+' sign below them.

all get to heav - en, What a day of re-joic - ing that will

12

Diagrammatic notation for the fourth line, consisting of 13 vertical columns of circles. Each column has 5 circles. The circles are filled (black) or empty (white) to represent fingerings on a tin whistle. Some columns have a '+' sign below them.

be! When we all see Je - sus, We'll sing and shout the vic - to - ry.

# THE STAR-SPANGLED BANNER

Words: Francis Scott Key  
Music: Anonymous

0 — say, can you see, by the dawn's ear - ly light, What so

5 proud - ly we hailed at the twi - light's last gleam - ing? Whose broad

9 stripes and bright stars, through the per - i - lous fight, O'er the

13 ram - parts we watched, were so gal - lant - ly stream - ing? And the

17

rock - ets' red glare, the bombs burst - ing in air, Gave

21

proof through the night that our flag was still there. O

25

say, does that star - span - gled ban - ner yet wave O'er the

29

land of the free, and the home of the brave?

# MY COUNTRY, 'TIS OF THEE

Words: Samuel Smith  
 Music: Thesaurus Musicus. 1744

1

My coun - try, 'tis of thee, Sweet land of lib - er - ty, Of thee I

6

sing: Land where my fa - thers died, Land of the pil - grim's pride,

11

From ev - 'ry moun - tain side Let free - dom ring!

# AMERICA THE BEAUTIFUL

Words: Katherine Bates  
Music: Samuel Ward

4

O beau - ti - ful for spa - cious skies, For am - ber waves of grain, For

5

pur - ple moun - tain maj - es - ties A - bove the fruit - ed plain! A -

9

mer - i - ca! A - mer - i - ca! God shed His grace on thee; And

13

crown thy good with broth - er - hood From sea to shin - ing sea.